

Sigenergy Smart Breaker Solution (Residential)

2026/01



SIGENERGY

Pure on-grid ESS system

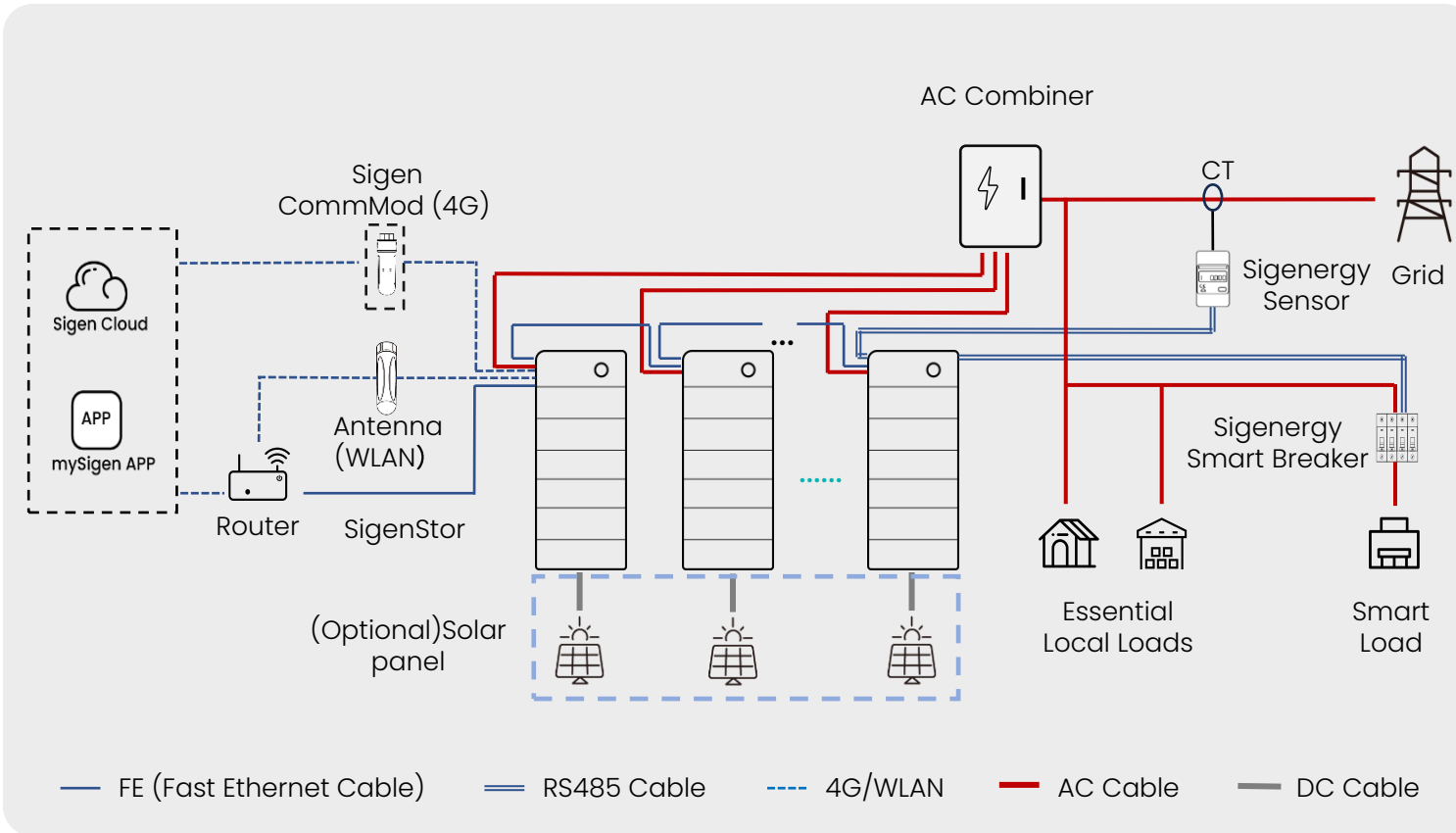

Boundary condition

1. Stable grid
2. Meter is used for power control at the grid connection point (e.g. Zero-injection, Maximum self-consumption, etc.)
3. Optional Ethernet, WIFI, and 4G for single unit, **recommended to use Ethernet hand in hand communication in parallel scenarios**
4. RS485 Cable is used for communication between SigenStor and Sigenenergy Smart Breaker.
5. The RS485-1 port is used on SigenStor Comm. Port for Sigenenergy Smart Breaker.
6. The size of Sigenenergy smart breaker: 16A, 32A, 63A for both 2P and 4P smart breakers, which can be compatible with single phase and three phase load.
7. Multiple smart breakers (Support Max. 10 pcs): The signal cables are connected hand by hand to SigenStor

On-grid/off grid switching system-whole backup

If there is no smart port on Gateway/the smart port of Gateway has been occupied

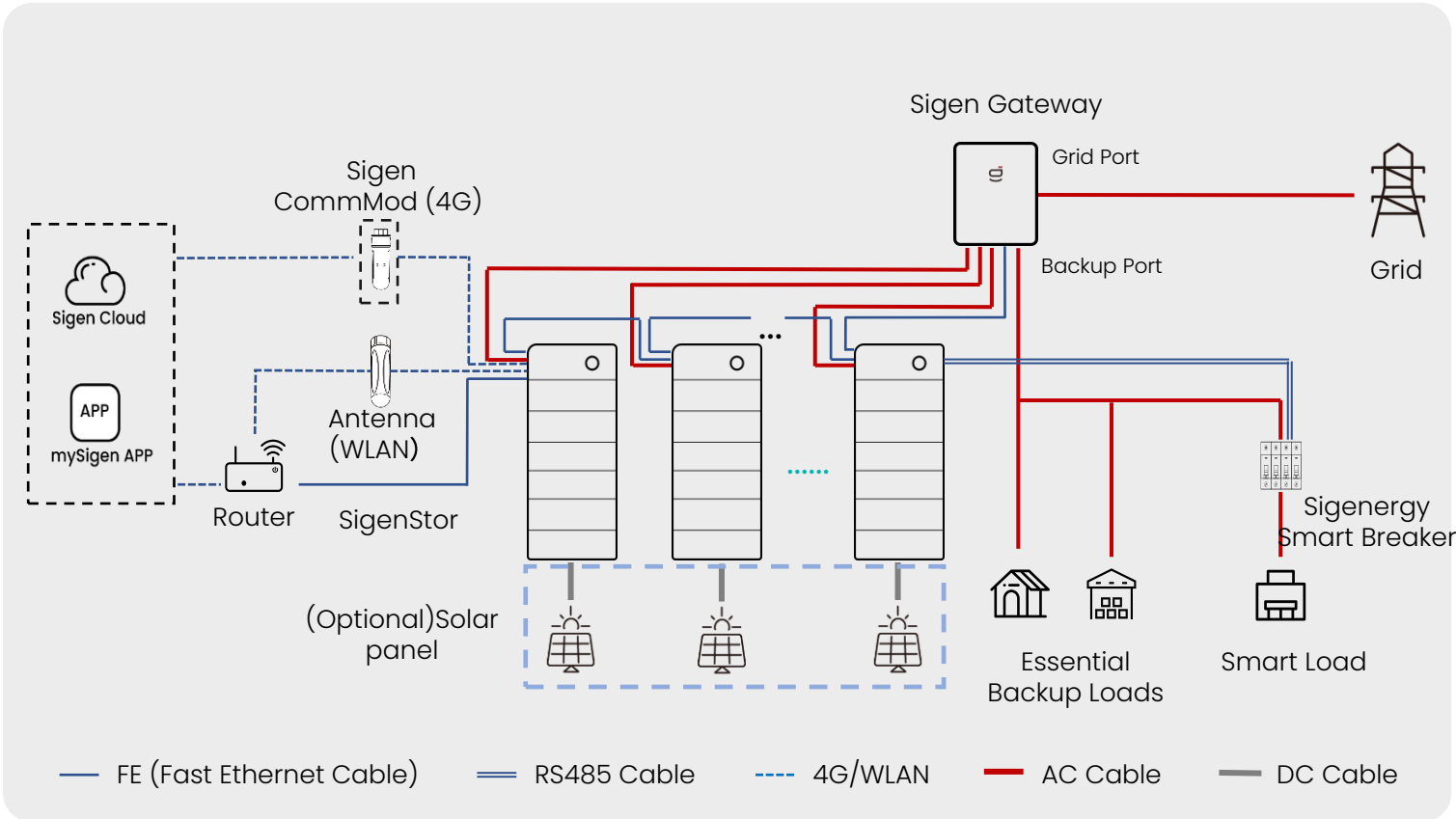

Boundary condition

1. Unstable grid.
2. No generator or other power sources
3. Whole system backup
4. Optional Ethernet, WIFI, and 4G for single unit, recommended to use Ethernet hand in hand
5. Communication devices(e.g.: router) requires power supply from the Gateway backup port
6. RS485 Cable is used for communication between SigenStor and Sigenery Smart Breaker, which can realize the smart load control
7. The size of Sigenery smart breaker: 16A, 32A, 63A for both 2P and 4P smart breakers, which can be compatible with single phase and three phase load.
8. Multiple smart breakers (Support Max. 10 pcs): The signal cables are connected hand by hand to SigenStor RS485-1 port or Gateway (If Gateway has spare RS485 port)

Grid + DG system-DG directly connect to Gateway

If there is no smart port on Gateway/the smart port of Gateway has been occupied

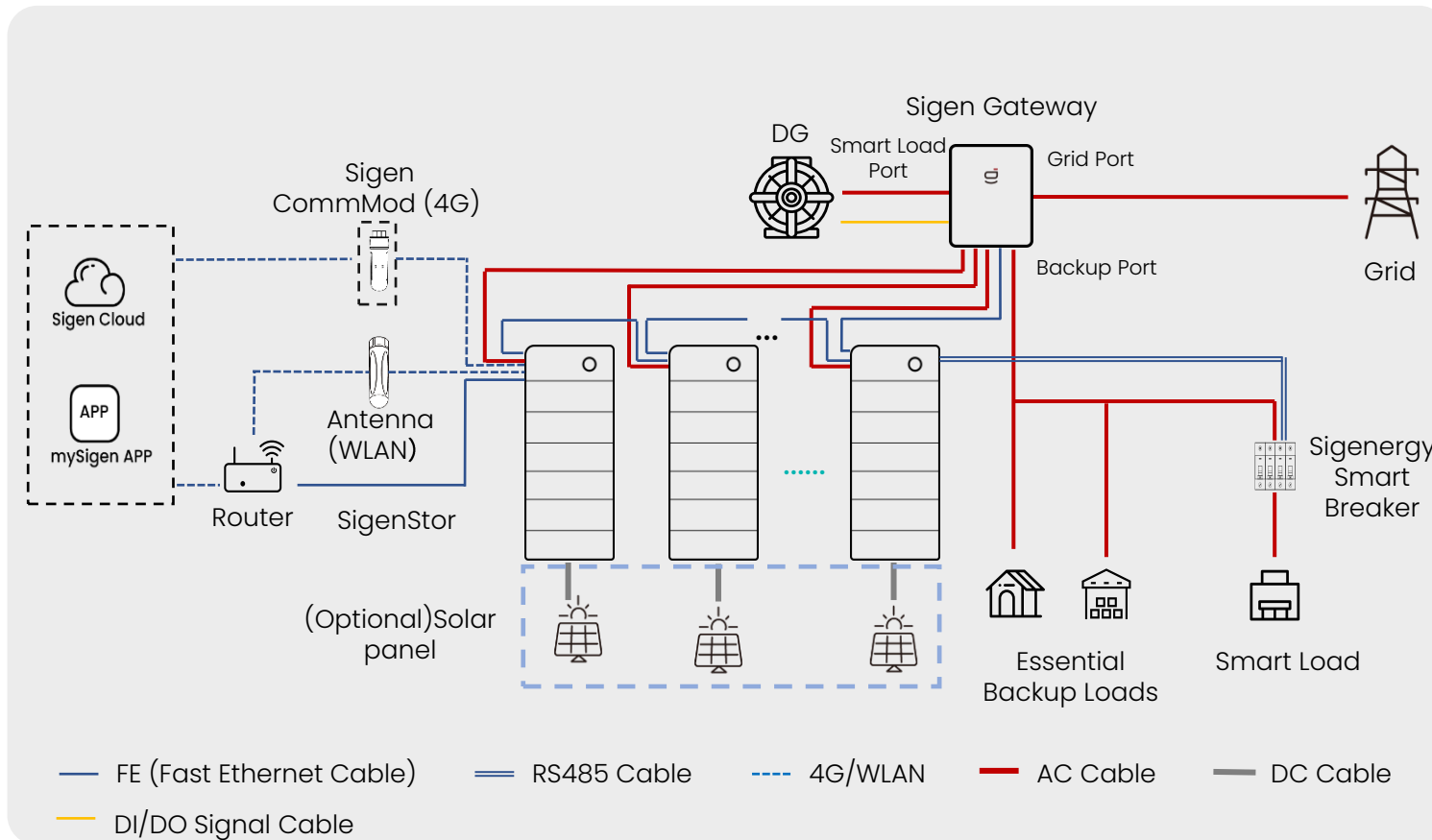

Boundary condition

1. Unstable grid.
2. With diesel generator, directly connected to the Gateway Smart Port.
3. Optional Ethernet, WIFI, and 4G for single unit, recommended to use Ethernet hand in hand
4. Diesel Generator can support automatic or manual start. If Gateway is required to control the generator to start automatically, the generator must support dry contact 2-wire start or AMF (automatic mains failure) start.
5. Requirement for Diesel Generator: single phase voltage range: 161-264V, frequency range: 45-55Hz (50Hz system), 55-65Hz (60Hz system), and the power quality of the generator must meet the power quality requirements of the inverter.
6. Communication devices(e.g.: router) requires power supply from the Gateway backup port.
7. RS485 Cable is used for communication between SigenStor and Sigenenergy Smart Breaker, which can realize the smart load control
8. The size of Sigenenergy smart breaker: 16A, 32A, 63A for both 2P and 4P smart breakers, which can be compatible with single phase and three phase load.
9. Multiple smart breakers (Support Max. 10 pcs): The signal cables are connected hand by hand to SigenStor RS485-1 port or Gateway (If Gateway has spare RS485 port)

Grid + DG system – DG & grid connect to Gateway via ATS

If there is no smart port on Gateway/the smart port of Gateway has been occupied

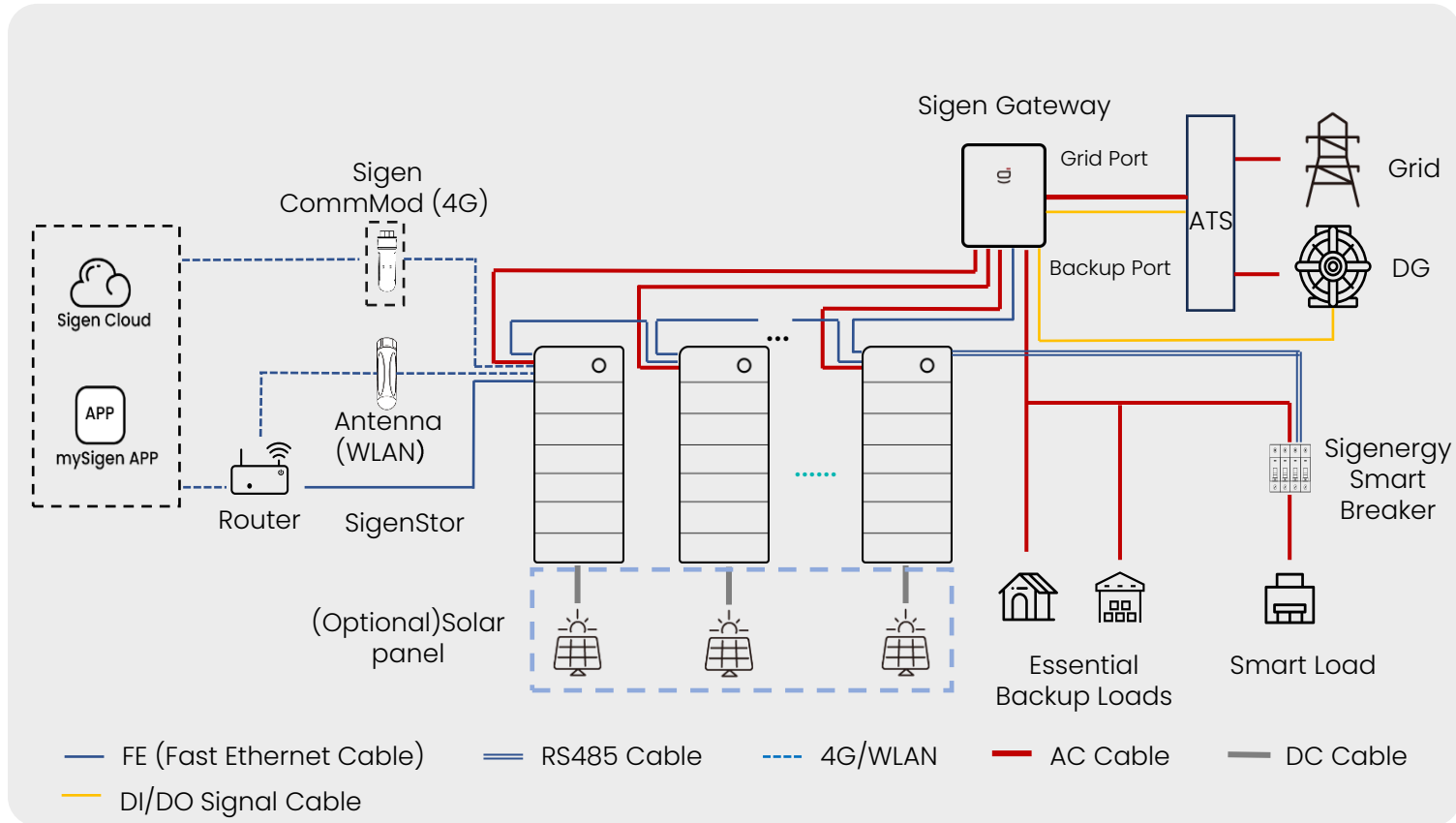

Boundary condition

1. Unstable grid.
2. With diesel generator and need to configure ATS. DG and the grid are connected to the Gateway grid port through ATS
3. Optional Ethernet, WIFI, and 4G for single unit, recommended to use Ethernet hand in hand
4. Diesel Generator can support automatic or manual start. If Gateway is required to control the generator to start automatically, the generator must support dry contact 2-wire start or AMF (automatic mains failure) start; At the same time, the ATS needs to have a dry contact status signal output to the Gateway.
5. Requirement for Diesel Generator: single phase voltage range: 161~264V, frequency range: 45~55Hz (50Hz system), 55~65Hz (60Hz system), and the power quality of the generator must meet the power quality requirements of the inverter.
6. Communication devices(e.g.: router) requires power supply from the Gateway backup port.
7. RS485 Cable is used for communication between SigenStor and Sigenenergy Smart Breaker, which can realize the smart load control
8. The size of Sigenenergy smart breaker: 16A, 32A, 63A for both 2P and 4P smart breakers, which can be compatible with single phase and three phase load.
9. Multiple smart breakers (Support Max. 10 pcs): The signal cables are connected hand by hand to SigenStor RS485-1 port or Gateway (If Gateway has spare RS485 port)

No grid, ESS+ DG system (DG connected to grid port)

If there is no smart port on Gateway/the smart port of Gateway has been occupied

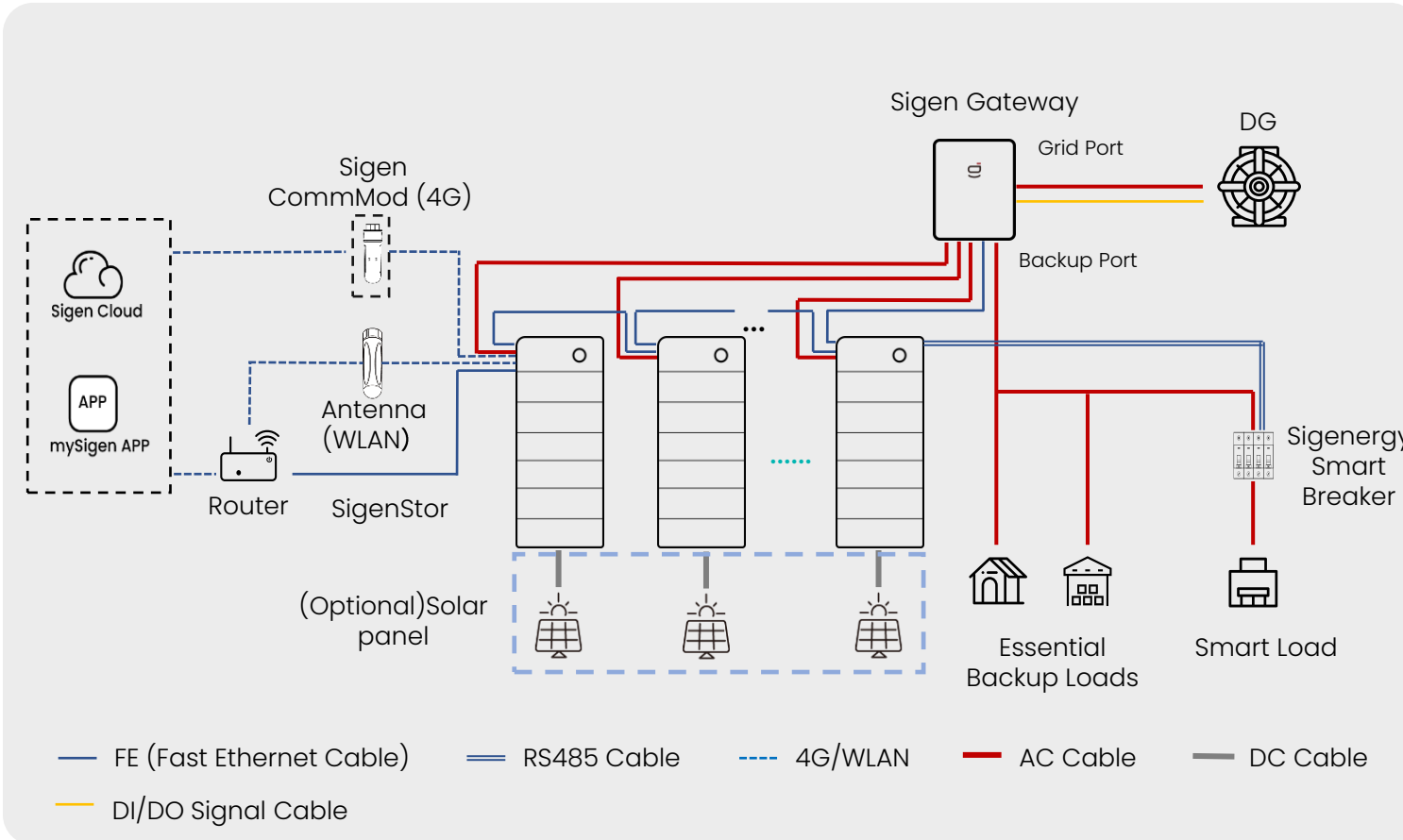

Boundary condition

1. No Grid
2. With one diesel generator. Generator directly connected to the Gateway Grid Port.
3. Optional Ethernet, WIFI, and 4G for single unit, recommended to use Ethernet hand in hand
4. Diesel Generator can support automatic or manual start. If Gateway is required to control the generator to start automatically, the generator must support dry contact 2-wire start or AMF (automatic mains failure) start.
5. Requirement for Diesel Generator: single phase voltage range: 161-264V, frequency range: 45-55Hz (50Hz system), 55-65Hz (60Hz system), and the power quality of the generator must meet the power quality requirements of the inverter.
6. RS485 Cable is used for communication between SigenStor and Sigenenergy Smart Breaker, which can realize the smart load control
7. The size of Sigenenergy smart breaker: 16A, 32A, 63A for both 2P and 4P smart breakers, which can be compatible with single phase and three phase load.
8. Multiple smart breakers (Support Max. 10 pcs): The signal cables are connected hand by hand to SigenStor RS485-1 port or Gateway (If Gateway has spare RS485 port)

No grid, ESS+ DG system (DG connected to smart load port)

If there is no smart port on Gateway/the smart port of Gateway has been occupied

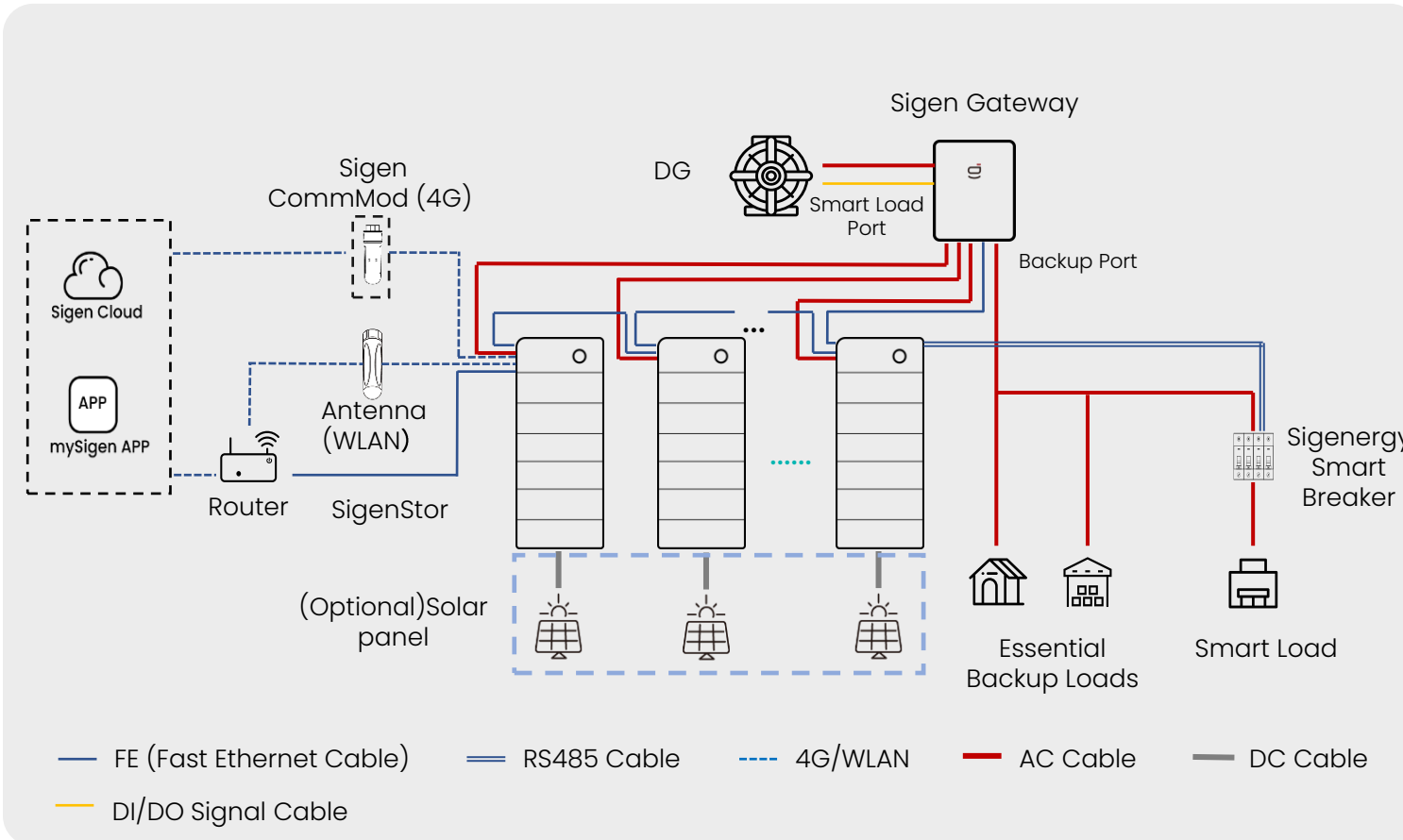

Boundary condition

1. No Grid
2. With one diesel generator. Generator directly connected to the Gateway Grid Port.
3. Optional Ethernet, WIFI, and 4G for single unit, recommended to use Ethernet hand in hand
4. Diesel Generator can support automatic or manual start. If Gateway is required to control the generator to start automatically, the generator must support dry contact 2-wire start or AMF (automatic mains failure) start.
5. Requirement for Diesel Generator: single phase voltage range: 161-264V, frequency range: 45-55Hz (50Hz system), 55-65Hz (60Hz system), and the power quality of the generator must meet the power quality requirements of the inverter.
6. RS485 Cable is used for communication between SigenStor and Sigenenergy Smart Breaker, which can realize the smart load control
7. The size of Sigenenergy smart breaker: 16A, 32A, 63A for both 2P and 4P smart breakers, which can be compatible with single phase and three phase load.
8. Multiple smart breakers (Support Max. 10 pcs): The signal cables are connected hand by hand to SigenStor RS485-1 port or Gateway (If Gateway has spare RS485 port)

No grid, no DG system

If there is no smart port on Gateway/the smart port of Gateway has been occupied

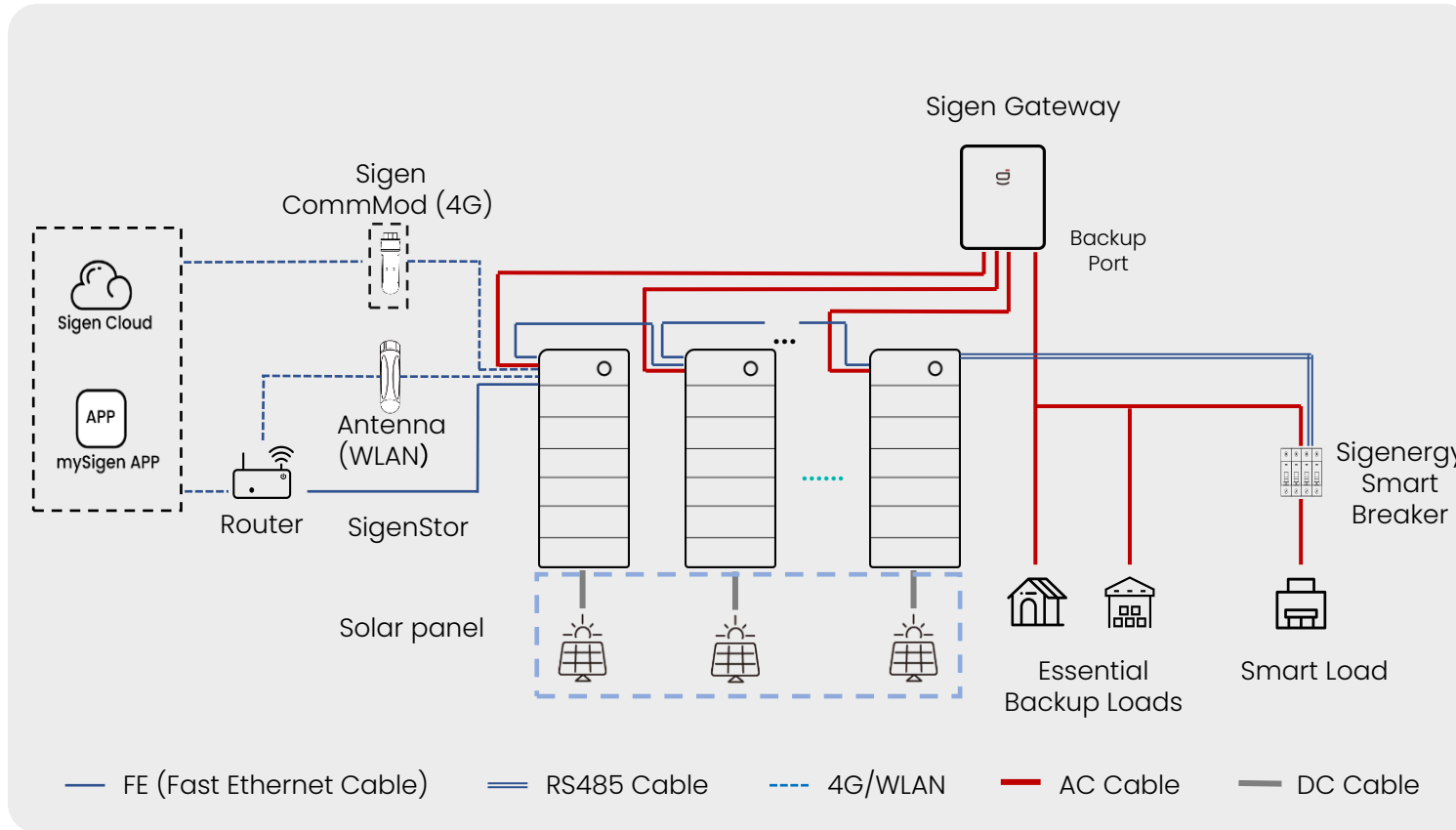

Boundary condition

1. No grid, no diesel generator or other power sources.
2. Both PV modules and batteries are necessary
3. When the PV-ESS has power, it supplies the load. When the PV-ESS has no power, the load can be powered off at any time.
4. Only the PV system charges the battery, and do not support external power charge the battery.
5. RS485 Cable is used for communication between SigenStor and Sigenenergy Smart Breaker, which can realize the smart load control
6. The size of Sigenenergy smart breaker: 16A, 32A, 63A for both 2P and 4P smart breakers, which can be compatible with single phase and three phase load.
7. Multiple smart breakers (Support Max. 10 pcs): The signal cables are connected hand by hand to SigenStor RS485-1 port or Gateway (If Gateway has spare RS485 port)

Retrofit-backup system (3rd party inverter)

If there is no smart port on Gateway/the smart port of Gateway has been occupied

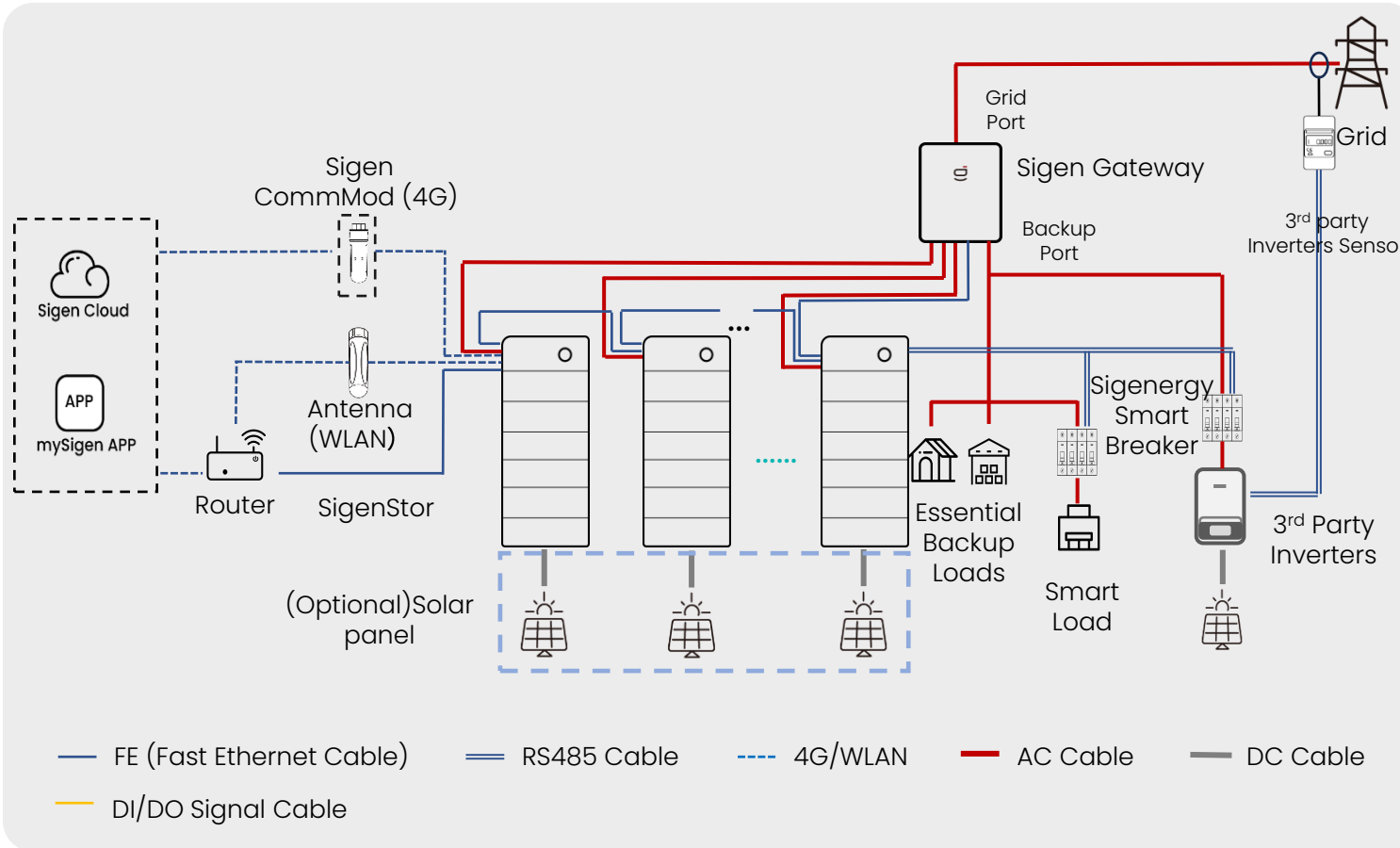

Boundary condition

1. Unstable grid and requirement for back-up.
2. There are single or multiple third-party pure grid-connected inverters, no third-party battery.
3. Third-party inverters cannot communicate with the Sigenenergy System
4. For on-grid mode, the sigenenergy system can achieve whole system zero export and maximum self-consumption.
5. The third-party inverter can charge the nSigenenergy battery
6. The power of the third-party inverter must be less than the total power of the SigenStor
7. Meter and communication devices(e.g.: router) requires power supply from the Gateway backup port.
8. RS485 Cable is used for communication between SigenStor and Sigenenergy Smart Breaker, which can realize the smart load control
9. The size of Sigenenergy smart breaker: 16A, 32A, 63A for both 2P and 4P smart breakers, which can be compatible with single phase and three phase load.
10. Multiple smart breakers (Support Max. 10 pcs): The signal cables are connected hand by hand to SigenStor RS485-1 port or Gateway (If Gateway has spare RS485 port)
11. The size of 3rd party inverter can not exceed the size of smart breaker, 3rd party inverter can still work when the grid is off.

For Gateway HomePro TP-L (Retrofit-backup system)

No smart port on Gateway

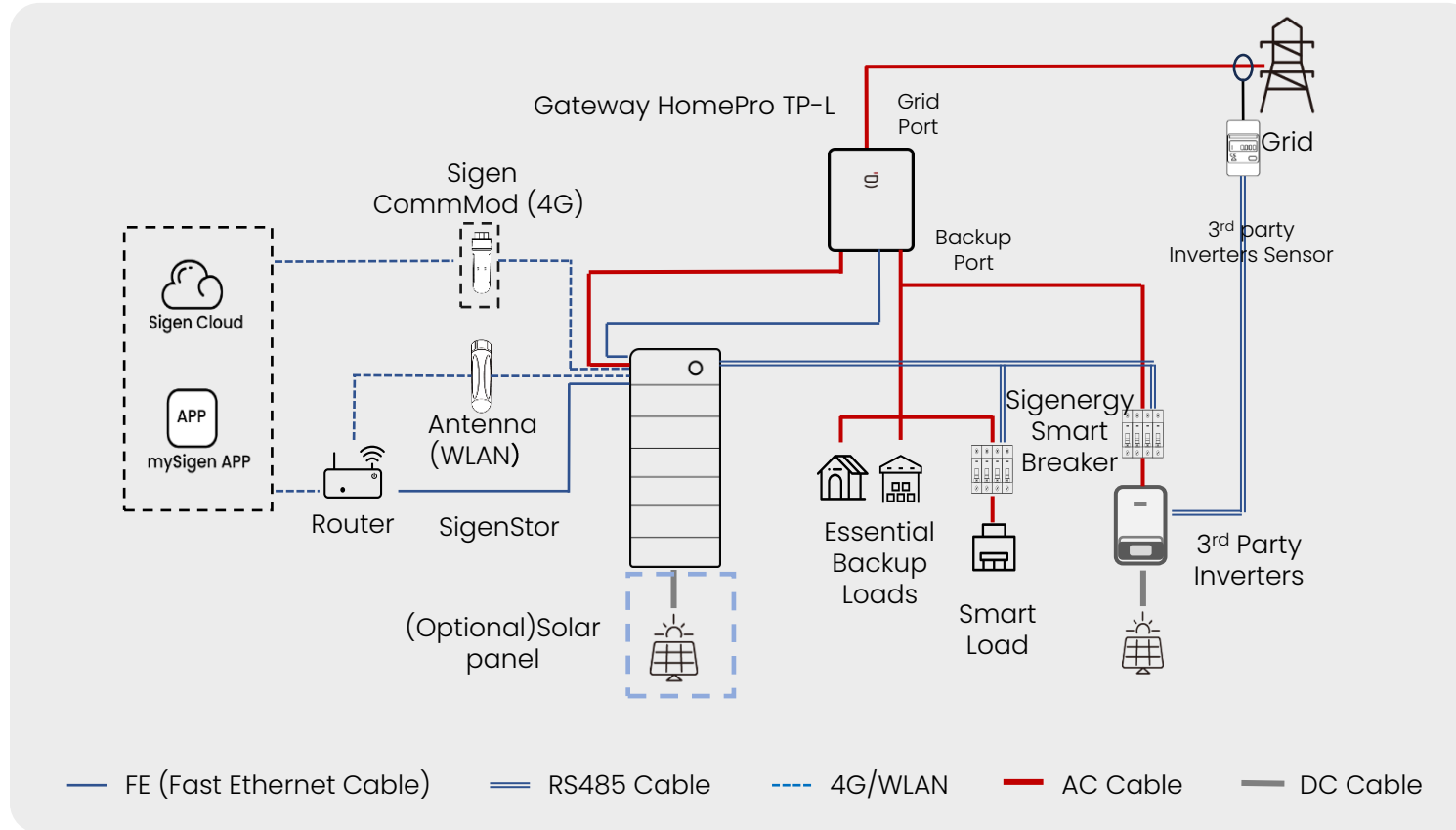

Boundary condition

1. Unstable grid and requirement for back-up.
2. There are single or multiple third-party pure grid-connected inverters, no third-party battery.
3. Third-party inverters cannot communicate with the Sigenenergy System
4. For on-grid mode, the sigenenergy system can achieve whole system zero export and maximum self-consumption.
5. The third-party inverter can charge the nSigenenergy battery
6. The power of the third-party inverter must be less than the total power of the Sigenstor
7. Meter and communication devices(e.g.: router) requires power supply from the Gateway backup port.
8. RS485 Cable is used for communication between Sigenstor and Sigenenergy Smart Breaker, which can realize the smart load control
9. The size of Sigenenergy smart breaker: 16A, 32A, 63A for both 2P and 4P smart breakers, which can be compatible with single phase and three phase load.
10. Multiple smart breakers (Support Max. 10 pcs): The signal cables are connected hand by hand to Sigenstor RS485-1 port or Gateway (If Gateway has spare RS485 port)
11. The size of 3rd party inverter can not exceed the size of smart breaker, 3rd party inverter can still work when the grid is off.

For Gateway HomePro TP-L (Generator connection via ATS)

No smart port on Gateway

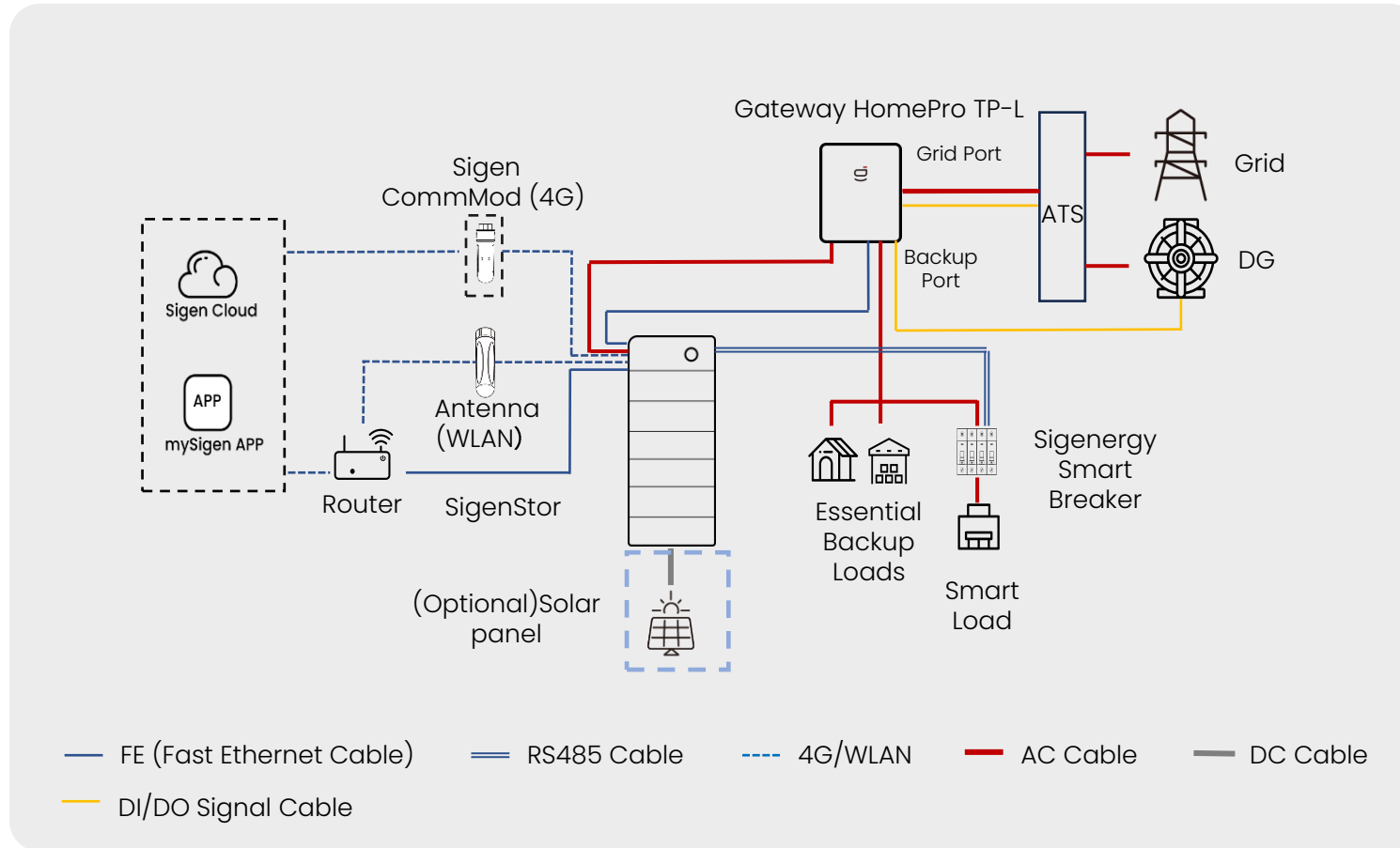

Boundary condition

1. Unstable grid.
2. With diesel generator and need to configure ATS. DG and the grid are connected to the Gateway grid port through ATS
3. Optional Ethernet, WIFI, and 4G for single unit, recommended to use Ethernet hand in hand
4. Diesel Generator can support automatic or manual start. If Gateway is required to control the generator to start automatically, the generator must support dry contact 2-wire start or AMF (automatic mains failure) start.; At the same time, the ATS needs to have a dry contact status signal output to the Gateway.
5. Requirement for Diesel Generator: single phase voltage range: 161~264V, frequency range: 45~55Hz (50Hz system), 55~65Hz (60Hz system), and the power quality of the generator must meet the power quality requirements of the inverter.
6. Communication devices(e.g.: router) requires power supply from the Gateway backup port.
7. RS485 Cable is used for communication between SigenStor and Sigenery Smart Breaker, which can realize the smart load control
8. The size of Sigenery smart breaker: 16A, 32A, 63A for both 2P and 4P smart breakers, which can be compatible with single phase and three phase load.
9. Multiple smart breakers (Support Max. 10 pcs): The signal cables are connected hand by hand to SigenStor RS485-1 port or Gateway (If Gateway has spare RS485 port)
10. Sigenery Smart Breaker can not support the generator connection.

Thank you.

畅享绿色能源

Enjoy Green Energy



© 2023 Shanghai SIGEN New Energy Technology Co., Ltd. All Rights Reserved

Disclaimer: The information on this file is provided on an "as is" basis. To the fullest extent permitted by law, Shanghai SIGEN New Energy Technology Co., Ltd excludes all representations and warranties relating to this file and its contents or which is or may be provided by any affiliates or any other third party, including in relation to any inaccuracies or omissions in this file.