



ASW015K-TH/ASW020K-TH/ASW025K-TH

ASW29.9K-TH/ASW030K-TH

# Three phase hybrid inverter

## User Manual

## Contents

1	General information .....	4
1.1	About this document .....	4
1.2	Product validity .....	4
1.3	Target group .....	4
1.4	Symbols .....	5
2	Safety.....	6
2.1	Intended use .....	6
2.2	Important safety instructions .....	6
2.3	Symbols on the label .....	9
3	Unpacking and storage.....	10
3.1	Scope of delivery .....	10
3.2	Product storage .....	11
4	Inverter overview.....	12
4.1	Product description .....	12
4.2	Dimensions .....	13
4.3	LED indicator .....	13
4.4	Supported grid types.....	14
4.5	Terminology.....	14
4.6	Energy Management .....	16
4.7	Basic system solution .....	22
4.8	Parallel System .....	28
5	Mounting .....	31
5.1	Requirements for mounting.....	31
5.2	Taking out and moving the product .....	32
5.3	Mounting .....	33
6	Electrical connection.....	35
6.1	Connection Interface Description .....	35
6.2	Connecting additional grounding.....	35
6.3	Grid AC connection.....	36
6.4	EPS Load / Diesel Generator cable connection .....	41
6.5	DC Connection.....	43
6.6	Battery connection .....	48
6.7	Ai-Dongle connection with LAN cable.....	50
6.8	Communication Equipment Connection.....	52
7	Commissioning and operation .....	63
7.1	Inspection before commissioning .....	63
7.2	Commissioning procedure .....	63
8	Solplanet APP.....	64
8.1	Download and install .....	64
8.2	Setting parameters .....	64
8.3	Parallel parameter setting and using.....	67
8.4	Activated Arc-fault Circuit Interrupter (AFCI) .....	71

9	Decommissioning the product .....	73
9.1	Disconnecting the inverter from energy sources .....	73
9.2	Dismantling the inverter .....	75
10	Technical data .....	76
10.1	ASW015/020/025/29.9/030K-TH.....	76
10.2	General data .....	78
10.3	Protective device.....	78
11	Troubleshooting .....	80
12	Maintenance.....	82
12.1	Cleaning the contacts of the DC switch.....	82
12.2	Cleaning air inlet and outlet .....	82
13	Recycling and disposal .....	83
14	EU declaration of conformity.....	83
15	Service and warranty.....	83
16	Contact.....	84

# 1 General information

## 1.1 About this document

This document describes the mounting, installation, commissioning, configuration, operation, troubleshooting and decommissioning of the product as well as the operation of the product user interface.

The contents of this user manual may be updated or revised due to on-going product development and continuous improvement. The information in this guide is subject to change without notice. The latest version of this document, the quick installation guide and further information are to be found in PDF format at [www.solplanet.net](http://www.solplanet.net).

It is recommended that this document is stored in an appropriate location and be available at all times.

## 1.2 Product validity

This document is valid for the following models:

- ASW015K-TH
- ASW020K-TH
- ASW025K-TH
- ASW29.9K-TH
- ASW030K-TH

## 1.3 Target group

This document is intended for qualified persons who must perform the tasks exactly as described in this user manual.

All installation work must be performed by appropriately trained and qualified persons.

Qualified persons must possess the following skills:

- Knowledge of how an inverter works and is operated.
- Knowledge of how batteries work and are operated.
- Training in how to deal with the dangers and risks associated with installing, repairing and using electrical devices, batteries and installations.
- Training in the installation and commissioning of electrical devices.
- Knowledge of all applicable laws, standards and directives.
- Knowledge of and compliance with this document and all safety information.
- Not adhering to the prescribed instructions may potentially void the manufacturer's warranty. If in doubt please contact the local Solplanet service team.

## 1.4 Symbols

### **DANGER**

Indicates a hazardous situation which, if not avoided, will result in death or serious injury.

### **WARNING**

Indicates a hazardous situation which, if not avoided, could result in death or serious injury.

### **CAUTION**

Indicates a hazardous situation which, if not avoided, could result in minor or moderate injury.

### **NOTICE**

Indicates a situation which, if not avoided, can result in property damage.



Information that is important for a specific topic or goal, however not related to safety.

## 2 Safety

### 2.1 Intended use

The product is a transformerless hybrid inverter with four MPP trackers and one or two battery connections that feeds the direct current of the PV array into the connected battery or converts it to grid-compliant three-phase current and then feeds it into onsite loads and the utility grid. The product also can convert the DC current supplied by the battery into grid-compliant three phase current. The product supports bi-directional AC power flow which allows the batteries to be charged by grid supplied AC current.

- The product has a backup function that can continue to supply selected circuits with power from the battery or PV system in the event of a grid fault.
- The product is intended for indoor and outdoor applications.
- The product must only be connected with PV modules of protection class II (in accordance with IEC 61730, application class A).
- The product is not equipped with an integrated transformer and therefore has no galvanic isolation. The product must not be operated with PV modules which require functional grounding of either the positive or negative PV conductors. This can cause the product to be irreparably damaged. The product may be operated with PV modules with frames that require protective earthing.
- All components must remain within their permitted operating ranges and their installation requirements at all times.
- Use the product only in accordance with the information provided in the user manual and with the locally applicable standards and directives. Any other application may cause personal injury or damage to property.
- The product must only be operated in connection with an intrinsically safe lithium-ion battery approved by Solplanet. The entire battery voltage range must be completely within the permissible input voltage range of the product. The latest version of the Solplanet battery compatibility list can be found in PDF format at [www.solplanet.net](http://www.solplanet.net).
- The product must only be used in countries for which it is approved by Solplanet and the grid operator.
- Knowledge of all applicable laws, standards and directives.
- Knowledge of and compliance with this document and all safety information.
- The type label must be permanently attached to the product and must be in a legible condition.
- This document does not replace any regional, state, provincial, federal or national laws, regulations or standards that apply to the installation, electrical safety and use of the product.

### 2.2 Important safety instructions

The product has been designed and tested strictly according to the international safety requirements. As with all electrical or electronical devices, there are residual risks despite careful construction. To prevent personal injury and property damage and to ensure long-term operation of the product, read this section carefully and observe all safety information at all times.

#### **DANGER**

##### **Danger to life due to high voltages of the PV array or the battery!**

The DC cables connected to the battery or the PV array may be live. Touching the DC conductors or associated live components can cause lethal electric shocks. Disconnecting the DC connectors from the product under load, an electric arc may expose the user to electric shock and burns.

- Do not touch non-insulated cable ends.
- Do not touch the DC conductors.
- Do not touch any live components of the product.

- Do not open the product.
- Observe all safety information provided by the battery manufacturer.
- All work on the product must only be carried out by qualified personnel who have read and fully understood all safety information contained in this document and the user manual.
- Disconnect the product from all voltage and energy sources and ensure it cannot be reconnected before working on the product.
- Wear suitable personal protective equipment for all work on the product.

## **DANGER**

### **Danger to life due to electric shock when touching live components in backup mode!**

Regardless of the AC breaker and the PV switch of the inverter being switched off or disconnected, the parts of the system may still be live when the battery is providing power during backup mode.

- Do not open the product.
- Disconnect the product from all voltage and energy sources and ensure it can not be reconnected before working on the product.

## **DANGER**

### **Danger to life due to fire or explosion when batteries are fully discharged!**

Danger to life due to fire or explosion when batteries are fully discharged.

- Ensure the battery is not fully discharged before commissioning the system.
- Contact the battery manufacturer before proceeding if the battery is fully discharged.

## **DANGER**

### **Danger to life due to burns caused by electric arcs through short-circuit currents!**

Short-circuit currents in the battery can cause heat accumulation and electric arcs if the battery is short circuited or incorrectly installed. Heat accumulation and electric arcs may result in lethal injuries due to burns.

- Disconnect the battery from all voltage sources prior to performing any work on the battery.
- Only use properly insulated tools to prevent accidental electric shock or short circuits during installation.
- Observe all safety information of the battery manufacturer.

## **DANGER**

### **Danger to life due to electric shock when touching live system components in case of a ground fault!**

If a ground fault occurs, parts of the system may still be live. Touching live parts and cables may result in death or lethal injuries due to electric shock.

- Disconnect the product from voltage and energy sources and ensure it cannot be reconnected before working on the device.
- Handle PV module cables only by its insulation.
- Do not touch any parts of the substructure or frame of the PV array.
- Do not connect PV strings with ground faults to the product.

## **WARNING**

**Danger to life due to risk of fatal electric shock from damages to the measuring device caused by overvoltage!**

Overvoltage can damage a measuring device and result in voltage being present in the enclosure of the measuring device. Touching the live enclosure of the measuring device results in death or lethal injuries due to electric shock.

- Only use measuring devices with a measurement span equal to or higher than maximum voltage range of the product.

## **CAUTION**

**Risk of burns due to high temperature!**

Some parts of the enclosure can become hot during operation.

- During operation, do not touch any parts other than the enclosure lid of the product.

## **CAUTION**

**Risk of injury due to weight of product!**

Injuries may result if the product is incorrectly handled or dropped while being transported or mounted.

- Transport and lift the product carefully. Take the weight of the product into account.
- Wear suitable personal protective equipment for all work on the product.

## **NOTICE**

**Damage to the inverter due to electrostatic discharge.**

Internal components of the inverter can be irreparably damaged by electrostatic discharge.

- Ground yourself appropriately before touching any component.



**The country grid code set must be set correctly.**

Setting a country grid code which is not valid for your country and purpose, can cause a disturbance within the PV system and lead to problems with the grid operator. When selecting the country grid code set, please observe the locally applicable standards and directives as well as the properties of the PV system (e.g., PV system size, grid-connection point).

- If you are not sure which standards and directives are valid for your country or purpose, contact the grid operator.

## 2.3 Symbols on the label



### Beware of a danger zone!

This symbol indicates that the product must be additionally grounded if additional grounding or equipotential bonding is required at the installation site.



### Beware of high voltage and operating current!

The product operates at a high voltage and current. Work on the product must only be carried out by skilled and authorized personnel.



### Beware of hot surfaces!

The product can become hot during operation. Avoid contact during operation.



### WEEE Designation

Do not dispose of the product together with household waste. Dispose the product in accordance with local disposal regulations for electronic waste applicable in the country of installation.



### CE marking

The product complies with the requirements of the applicable EU directives.



### Certification mark

The product has been tested by TÜV and obtained the quality certification mark.



### CE marking

The product complies with the requirements of the applicable EU directives.



### Capacitor discharge

Danger to life due to high voltages in the inverter. Do not touch live parts for at least 5 minutes after disconnection from the power sources.



### Observe the documentation

Read and understand all documentation supplied with the product.

---

## 3 Unpacking and storage

### 3.1 Scope of delivery

Check the scope of delivery for completeness and any visible external damage. Contact your distributor if the scope of delivery is incomplete or damaged.

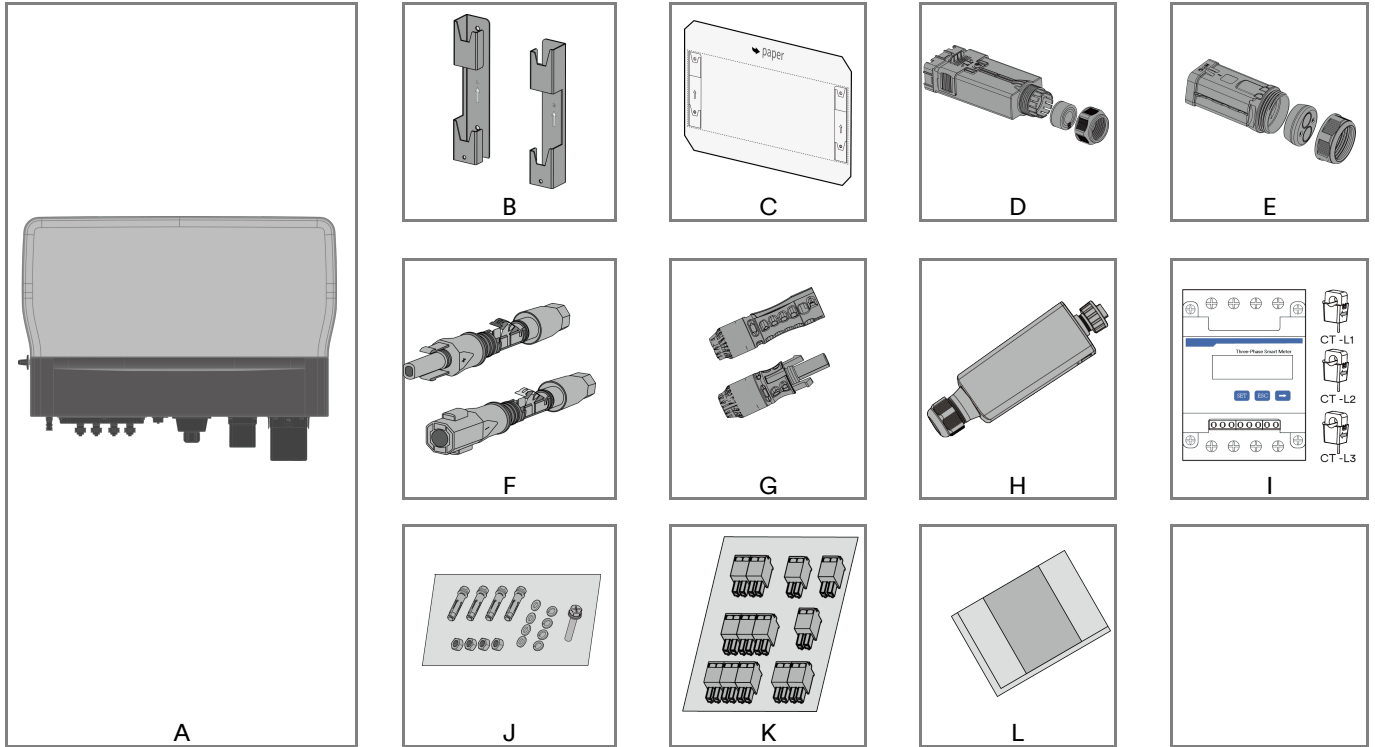

NO	Description	Quantity	
A	Inverter	1	
B	Mounting Bracket	1	
C	Mounting Bracket Template	1	
D	AC Connector	1	
E	Diesel Generator Connector	1	
	EPS Load Connector		
F	DC Connector(pair, positive & negative)	ASW015-020K-TH	4
		ASW025-030K-TH	8
G	Battery Connector(pair, positive & negative)	ASW015-020K-TH	1
		ASW025-030K-TH	2
H	Ai-Dongle	1	
I	Smart Meter(CTs included)	1	
J	Fastener Package	1	

K	Communication Terminal Package	1
L	Document package	1

## 3.2 Product storage

Suitable storage is required if the inverter is not installed immediately:

- Store the inverter in the original packaging.
- The storage temperature must be between -30°C to +60°C, and the storage relative humidity must be between 0 and 100%, non-condensing.
- The the inverter shall not be tilted or inverted when stored.
- Check the scope of delivery for completeness and any visible external damage. if it has been stored for half a year or more.
- For battery storage you can refer to the battery related user manuals.

## 4 Inverter overview

### 4.1 Product description

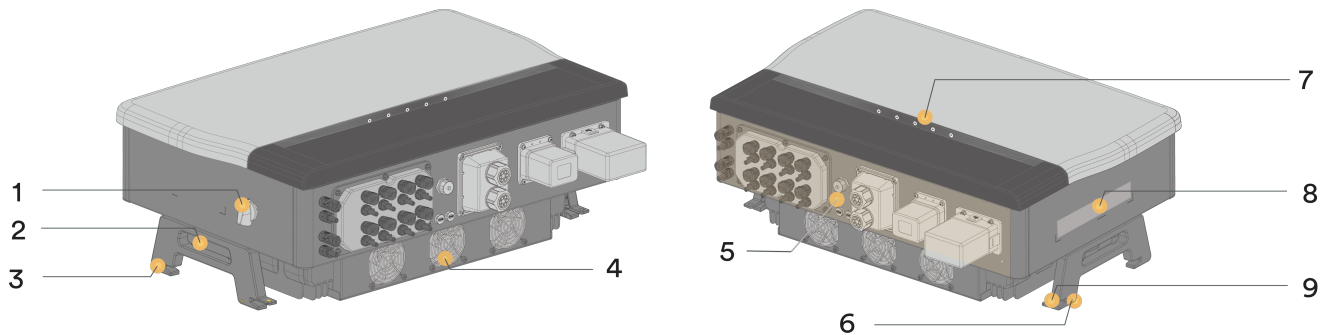
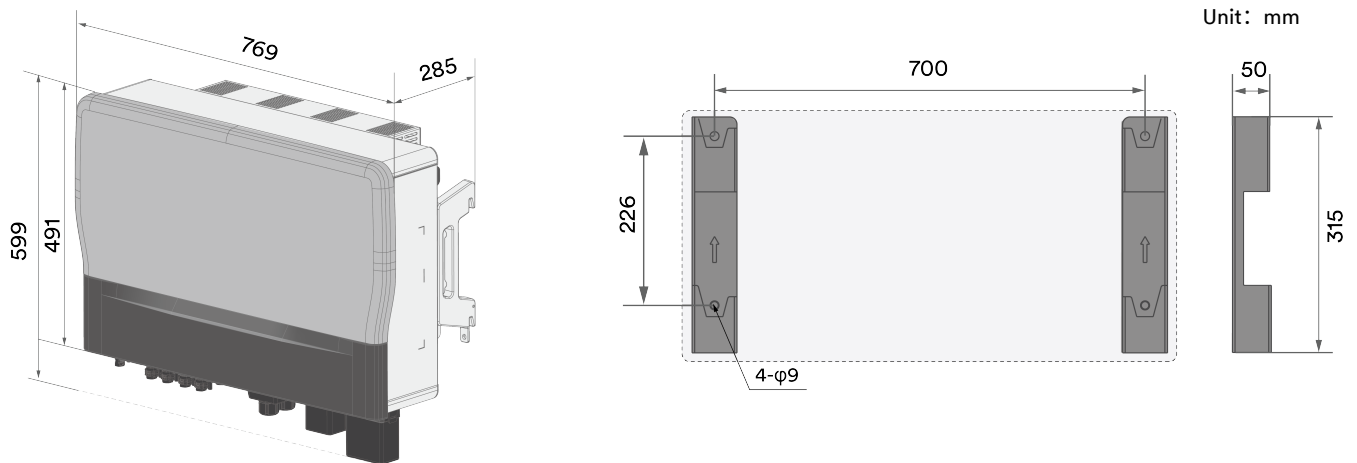

















Figure shown here is for reference only. The actual product received may differ.

NO	Name	Description
1	DC switch	Used to isolate the inverter from a DC input source. e.g. PV array
2	Recessed grip	Used to handle the inverter.
3	Mounting flange	Used to hang the inverter onto the mounting bracket.
4	Cooling fan	For inverter cooling.
5	Electrical connection interface	Includes AC terminals, DC connectors, battery connectors, EPS Load terminal, generator terminal, communication ports and an additional grounding terminal. For details, refer to "6.1 Connection Interface description".
6	Inverter threaded security hole	Used for securing the inverter to the mounting bracket. Located on the right side of the inverter.
7	LED indicator panel	Indicates the current working state of the inverter.
8	Type Labels	The type label clearly identifies the product. The type label must remain permanently attached to the product. This includes, but is not limited to, warning symbols, nameplates, and QR codes for product libraries.
9	Anti-theft holes	For installation of anti-theft locks.

## 4.2 Dimensions



## 4.3 LED indicator

Function	LED	Description
SOLAR	 Green Solid ON	The product operates normally and the PV array is available.
	 Green Blinking	The product is self-checking automatically, or the firmware is being updated.
	 OFF	Power from the PV array is not available.
BAT	 Green Solid ON	The product operates normally and the battery energy is available.
	 Green Blinking	The product is self-checking automatically, or the firmware is being updated.
	 OFF	Power from the battery is not available.
ERROR	 Yellow Solid ON	There is a warning fault, the communication between Ai-Dongle and inverter has failed, or the other warning fault. the warning message and the corresponding event number will be displayed on the APP or Cloud.
	 Red Solid ON	There is an error fault. The Error message and the corresponding event number will be displayed on the APP or Cloud.
	 OFF	The product is operating normally.
EPS	 Green Solid ON	The EPS port the product is available and operates normally.
	 Red Solid ON	The EPS port operates abnormally.
	 OFF	The EPS port of product stop operation.
GRID	 Green Solid ON	The product is connected and operates normally in non-off-grid mode, or the grid voltage is greater than the safety voltage(36V) in off-grid mode.
	 Red Solid ON	The GRID port operates abnormally in on-grid mode without battery.
	 OFF	The GRID port is disconnected, or grid operates abnormally with battery, or the grid voltage is less than the safety voltage(36V) in off-grid mode, or product stop operation.

## 4.4 Supported grid types

The grid network types supported by the product is TN-S, TN-C, TN-C-S, TT, as shown in the figure below:

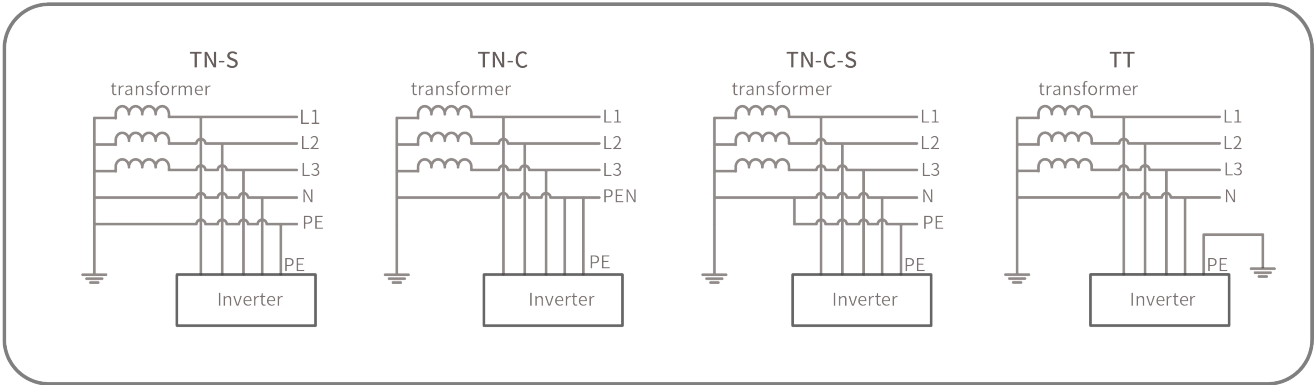

For the TT grid structure, the effective value of the voltage between the neutral wire and the ground wire must be less than 20 V.

## 4.5 Terminology

The product is equipped with the following interfaces and functions, for more information, refer to 6.8:

### Ai-Dongle

The product is equipped with an Ai-Dongle as standard, which it connects to the user interface of the Solplanet APP for configuring and monitoring the product. The Ai-Dongle can connect to the internet via WLAN or an ethernet cable. Solplanet communication products or a third-party monitoring device can be used if the Ai-Dongle is not connected.

### RS485 Interface

The product is equipped with several RS485 interfaces. Some RS485 interfaces are available via RJ45 ports and other RS485 interfaces are available via terminal blocks. RS485 can be connected to the third-party monitoring device or to the smart meter, etc.

### CAN Interface

The product is equipped with CAN interfaces.

The CAN interface is used to connect the BMS (Battery Management System) of the battery.

### ETHERNET Interface

The product is equipped with two ethernet interfaces. The ETH interface is used to support TCP/IP communication protocol, which can be connected to router. It also can be connected to the AI-HUB for Grid parallel function.

### Modbus RTU

The product is equipped with a modbus interface. A third-party communication device complying with the Solplanet Modbus protocol can be connected to the inverter.

### Export power control

The product is equipped with an export power limit function, so as to meet the requirements of various national standards or grid standards for limiting the output power at the grid connection point. The export power control solution measures the active power at the grid connection point and then uses this information to control the inverter's active power in order to prevent the inverter from exceeding the agreed export power limit.

The product is delivered with current transformers (Reserved) and a smart meter as standard. Either the current transformers or the smart meter (not both simultaneously) can be used to measure the export active power.

The smart meter that can be used with this product must be approved by Solplanet. For more information about the smart meter, please contact Solplanet service.

### **Multifunction Relay**

The product is equipped with two multifunction relays as standard. One of the relays can serve as a dry contact signal for controlling a diesel generator. When the diesel generator function in the Solplanet App is enabled and the diesel generator connection conditions are met, the open contact will switch to on (voltage free output). For more information, please contact Solplanet service.

### **ON/OFF interface**

This product has the function of starting/shutting down the inverter by means of a dry contact. For more information, please contact Solplanet service.

### **NS protection**

Depending on the total of the maximum apparent power of all power generation systems and storage systems at a network connection point  $\Sigma S_{Amax}$ , maybe the central NS protection at the central meter panel should be installed.

The product is equipped with an interface to connect the central NS protection device.

### **External output device**

This product is equipped with external output function. When the inverter is in the "ON" status, it will provide a 12 Vdc. For more information, please contact Solplanet service.

### **Inverter demand response modes (DRED)**

The product shall detect and initiate a response to all supported demand response commands according to the AS/NZS 4777.2 standard. The product only supports the demand response mode DRM 0.

### **Ripple control receiver interface**

Network security management requires that the power generation systems and storage systems must be able to reduce their active power to a value specified by the network operator at the network connection point without disconnecting from the network. Normally the grid company maybe use the ripple control receiver to do Network security management in Germany.

The product is equipped with an interface to connect the ripple control receiver.

### **Ai-Hub\_DI interface (Reserved)**

The terminal is a DI signal interface sent from the AI-HUB to the inverter. For more information, please contact with Solplanet service.

### **Current transformer interface (Reserved)**

The current transformers can be used to measure the active power at the grid connection point. The three current transformers can be connected to terminal.

### **EPS/Back-up function**

The inverter is equipped with a back-up function which acts as an emergency power supply (EPS). The back-up function ensures that the inverter, via the EPS output, continues to provide three phase power to supply emergency loads in the event of a utility grid failure. Power is provided by the battery and the PV array.

During back-up mode, the battery can continue to be charged from the PV array.

As soon as the utility grid is available again, the product will automatically re-connect to the grid and resume supplying power to the loads connected on the grid side.

### Earth fault alarm

This product complies with IEC 62109-2 clause 13.9 for earth fault alarm monitoring. If an earth fault alarm occurs, the red color LED indicator will light up. At the same time, the error code 38 will be sent to the Solplanet Cloud.

## 4.6 Energy Management

The energy management mode selected should be based on the user's application and preference. There are four energy management modes that can be chosen.

### Self-Consumption mode

Self-consumption prioritises the supply of the load with PV and battery energy resulting in an increase of the self-consumption and self-sufficiency rates.

Energy management during the daytime:

**Case 1:** PV power generation is lower than the power consumption and there is no battery energy available. The balance of load power, if any, is supplied from the utility grid.

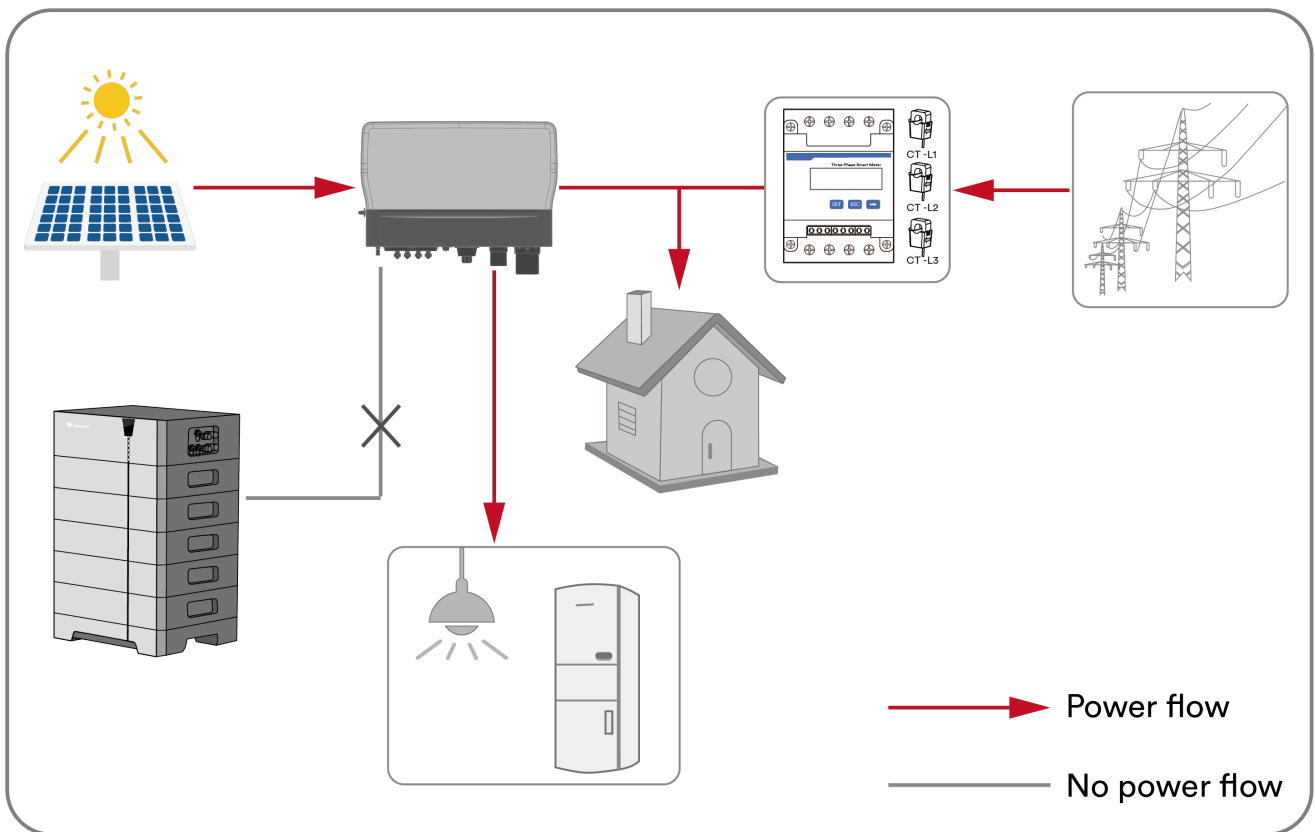

**Case 2:** PV power generation is lower than the power consumption and there is available battery energy. The balance of load power, is supplied from the battery and if needed from the utility grid.

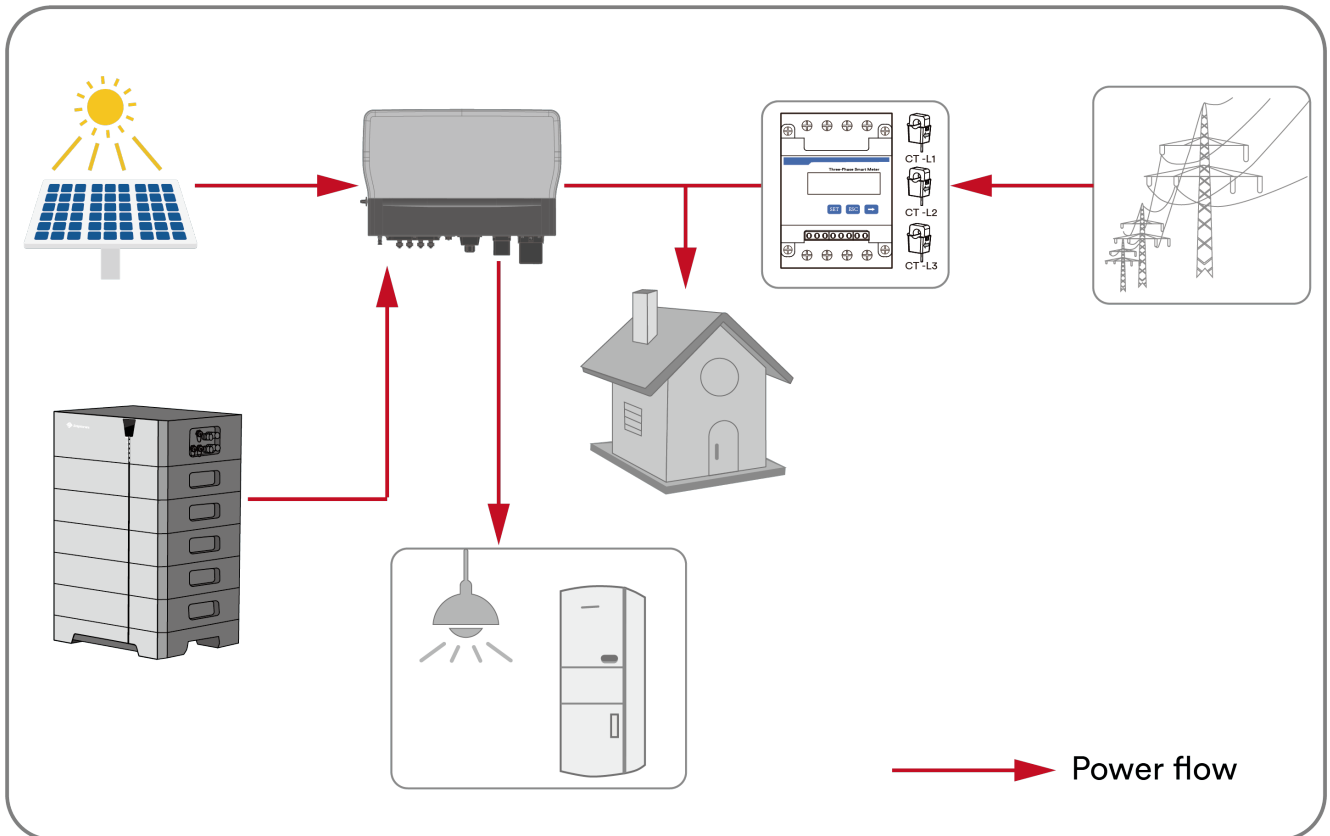

**Case 3:** PV power generation is larger than the power consumption. Battery charging via PV energy is prioritised. PV energy is exported to the utility grid if it is greater than the load and when the battery is completely charged.

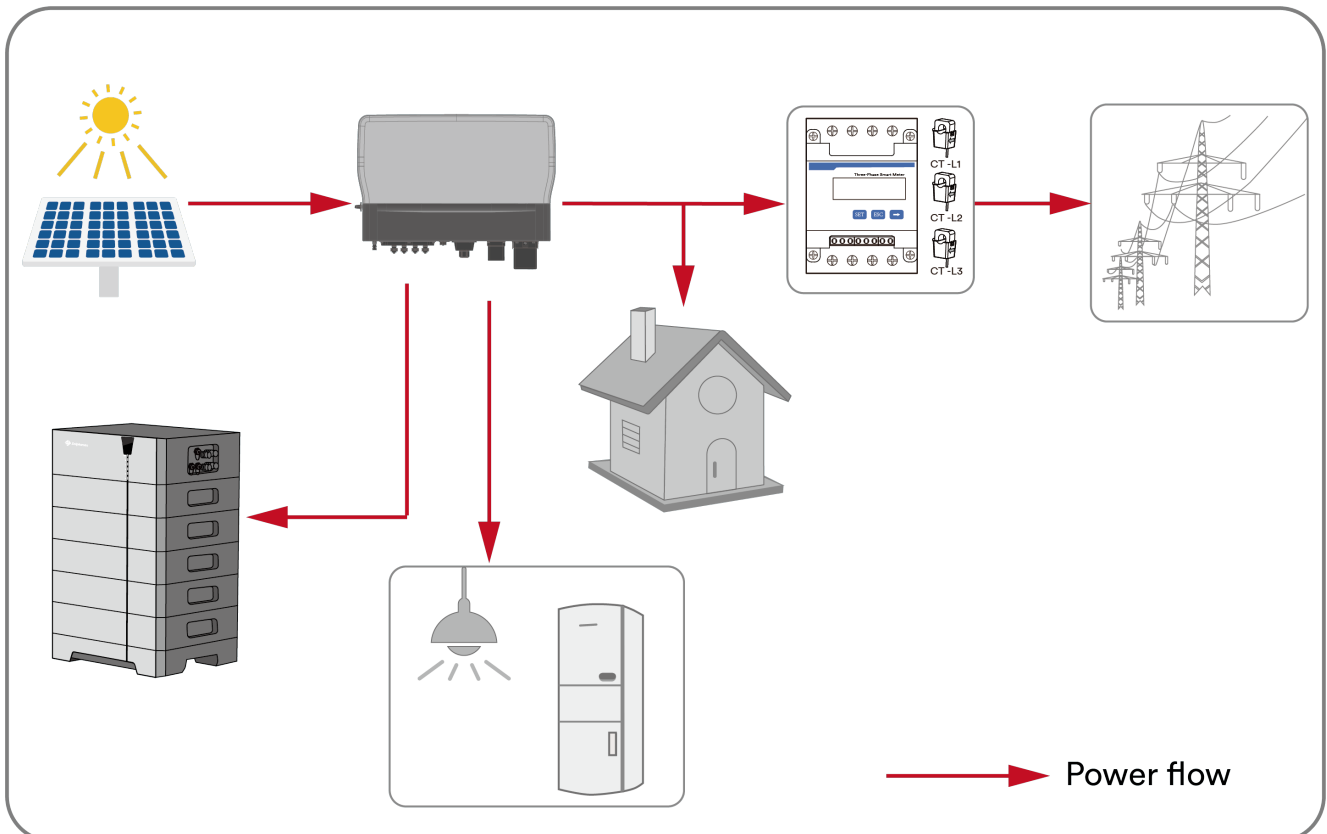

### Energy management during the night:

**Case 1:** Battery energy is available. The power consumption will be supplied by the battery and the balance, if required, will be supplied by the utility grid.

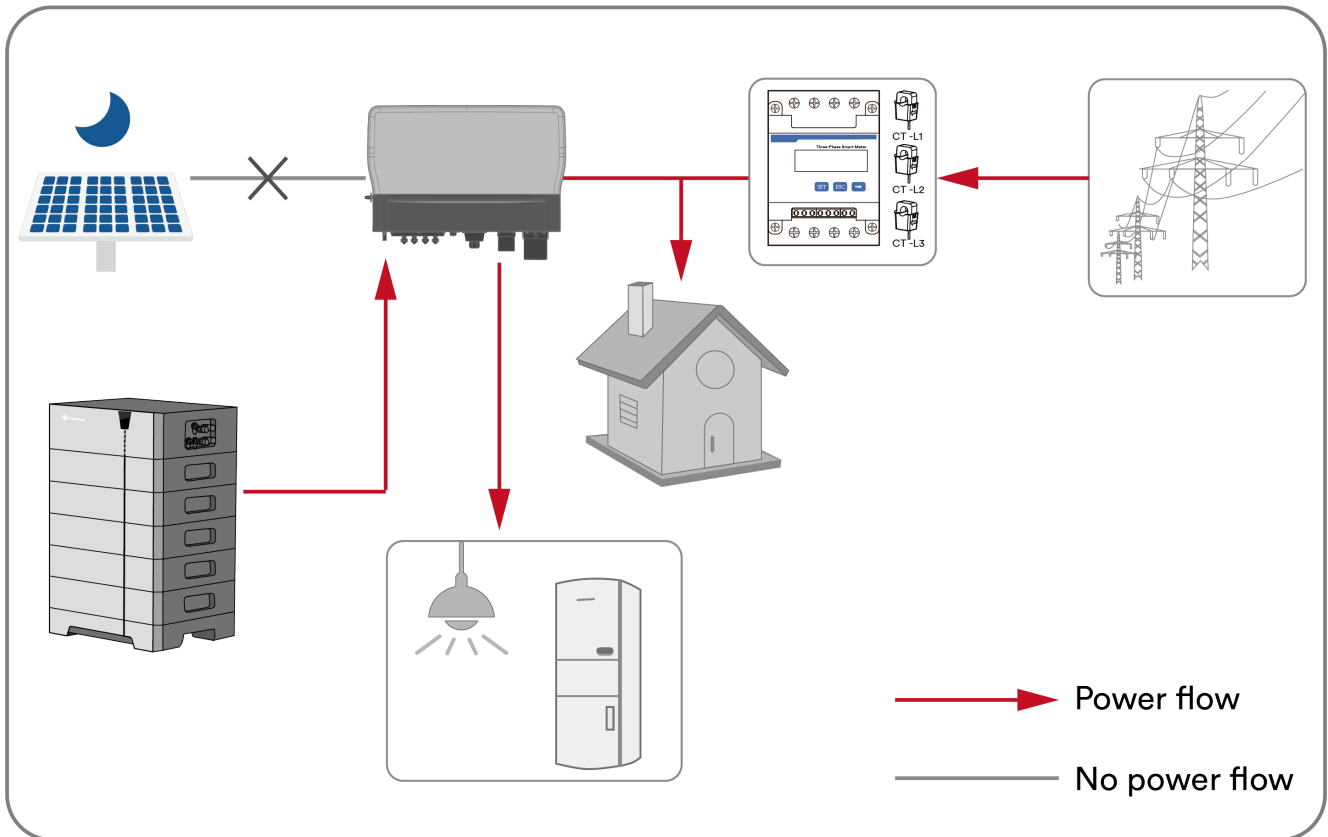

**Case 2:** Battery energy not available. The load power consumption will be supplied by the utility grid.

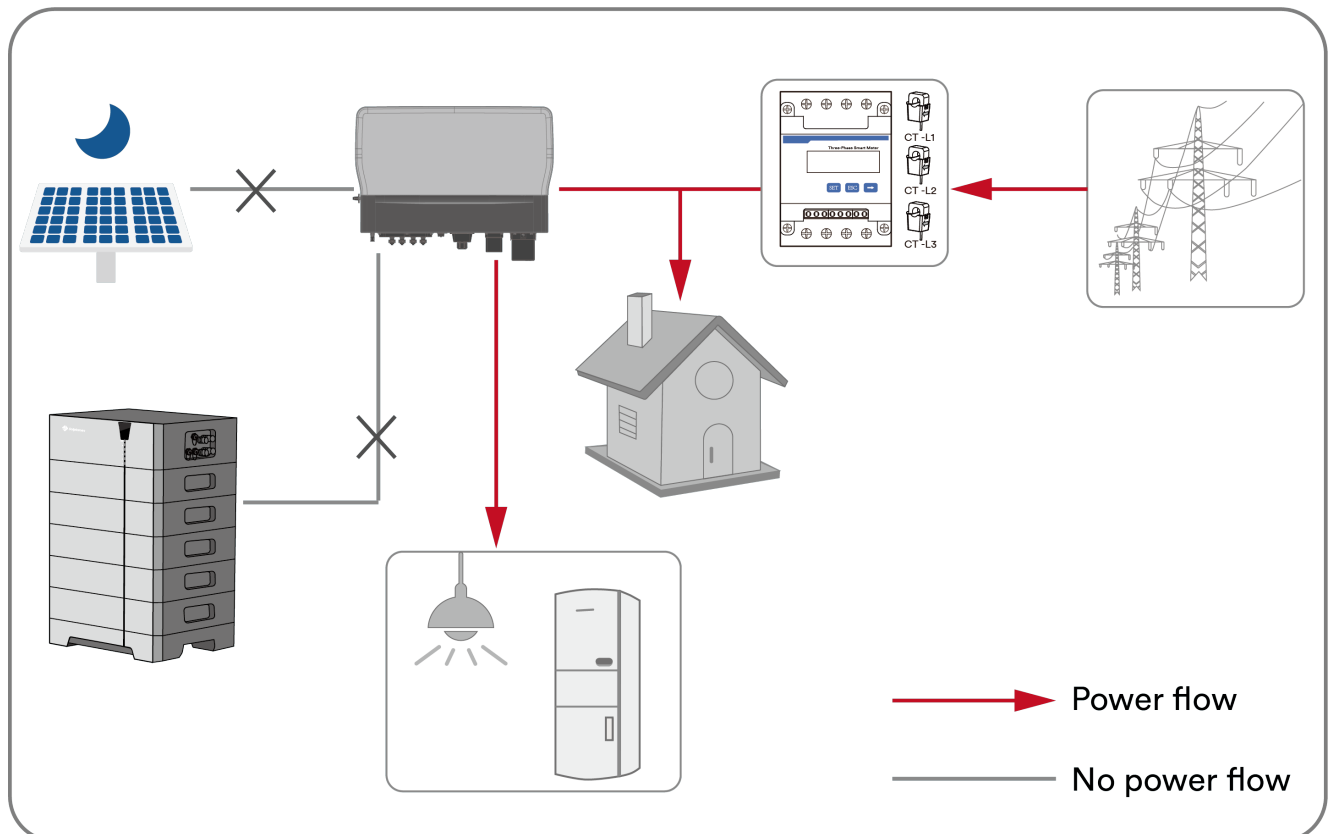

## Reserve mode

The battery is considered as a back-up energy storage device. PV power prioritises the charging of the battery if it is not completely charged. The battery discharges only during a loss of the utility grid.

**Case 1:** The battery is not completely charged. PV power will prioritise the charging of the battery. The balance of load power, if required, is supplied from the utility grid.

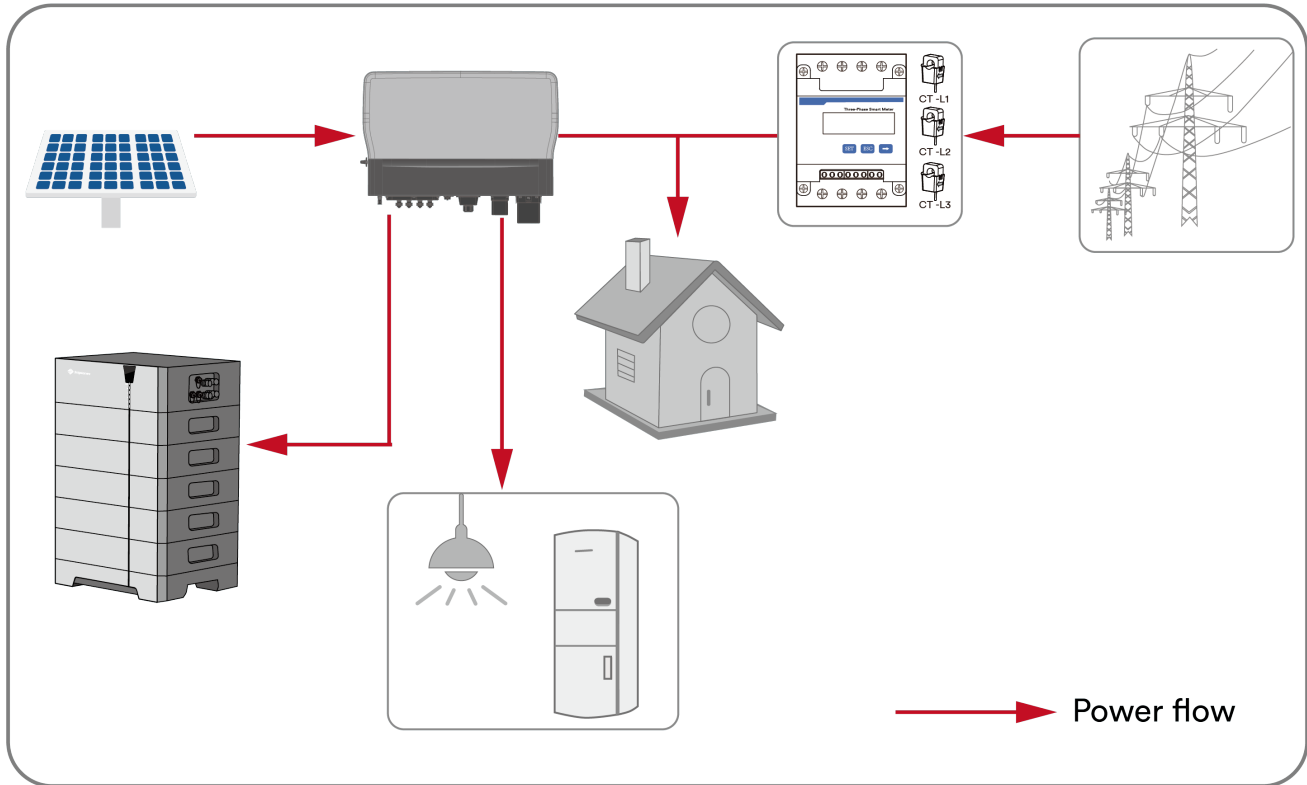

**Case 2:** The battery is completely charged, the load power consumption is supplied by excess PV power and the balance, if required, is supplied by the utility grid.

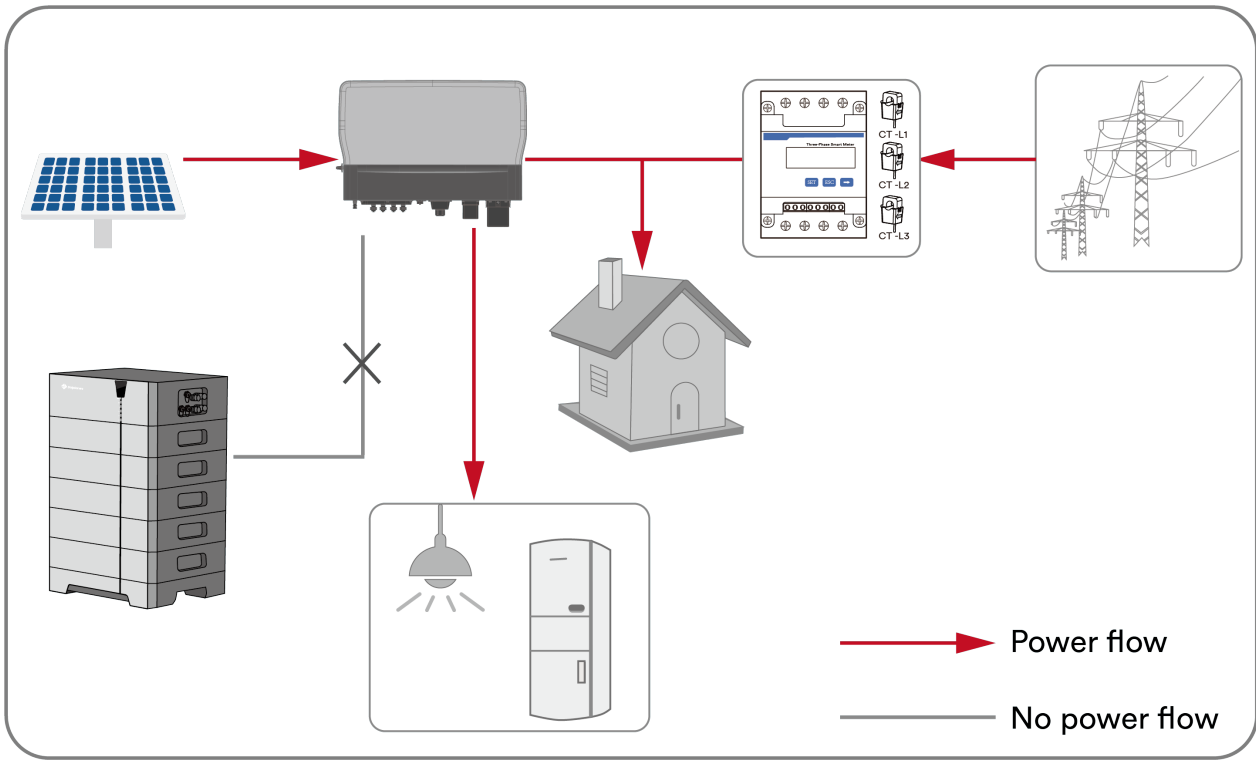

**Case 3:** The battery discharges when there is a loss of the utility grid.

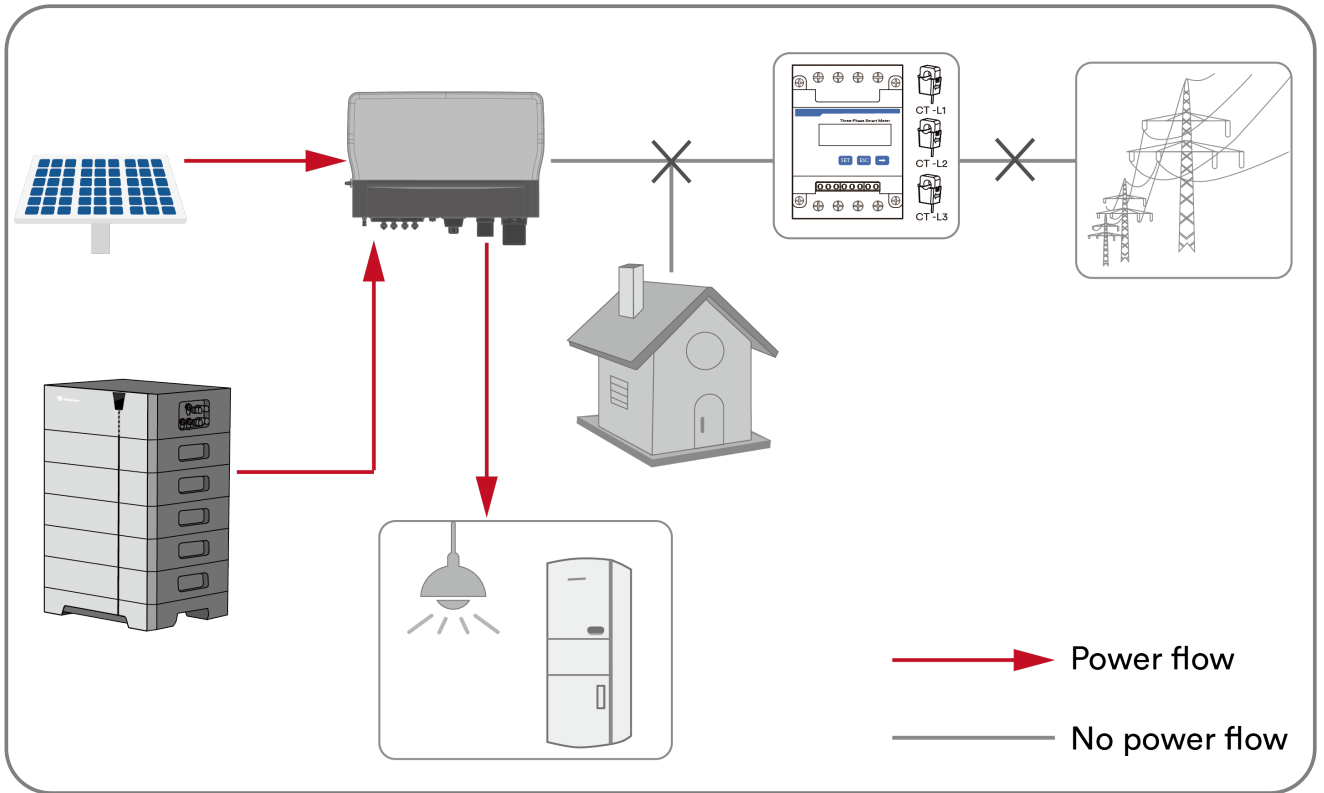

**With Generator**

A diesel generator is connected to the inverter. The inverter will send a command to start the generator when grid loss, the battery soc is too low and if PV energy can not support load.

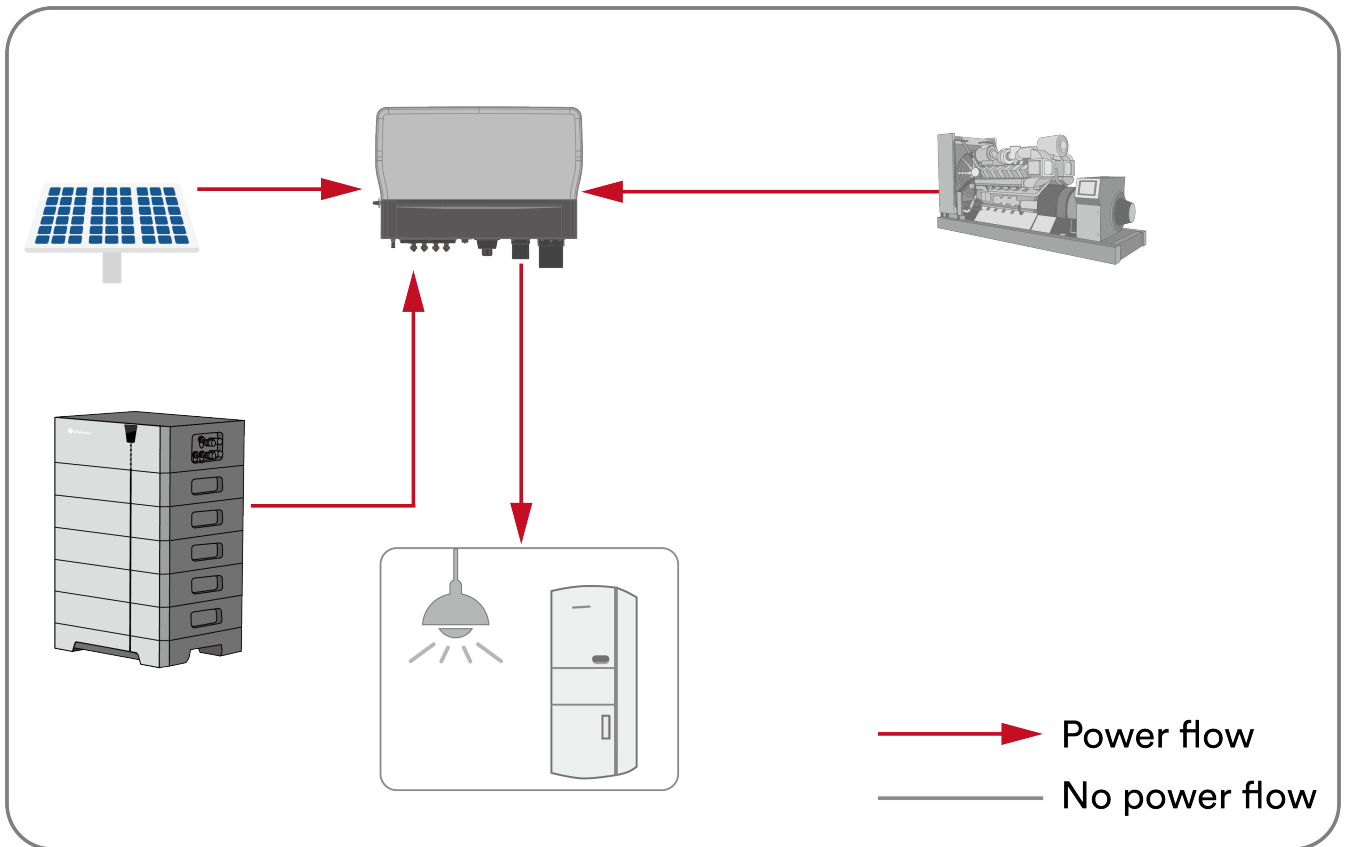

**With Smart-load**

When the household load is connected to the generator terminal, the system can determine whether to connect or disconnect the load of the port based on the battery SOC value set by the user.

The smart load mode mainly refers to the load that does not need continuous power supply in the customer's access home. The load can only be used when the customer thinks that the energy is sufficient. For example, when the SOC value of the battery is greater than the customer's set value, the energy of the grid, PV or battery can supply power to the smart load. The smart load is disconnected when the SOC value of the battery is less than the value set by the customer.

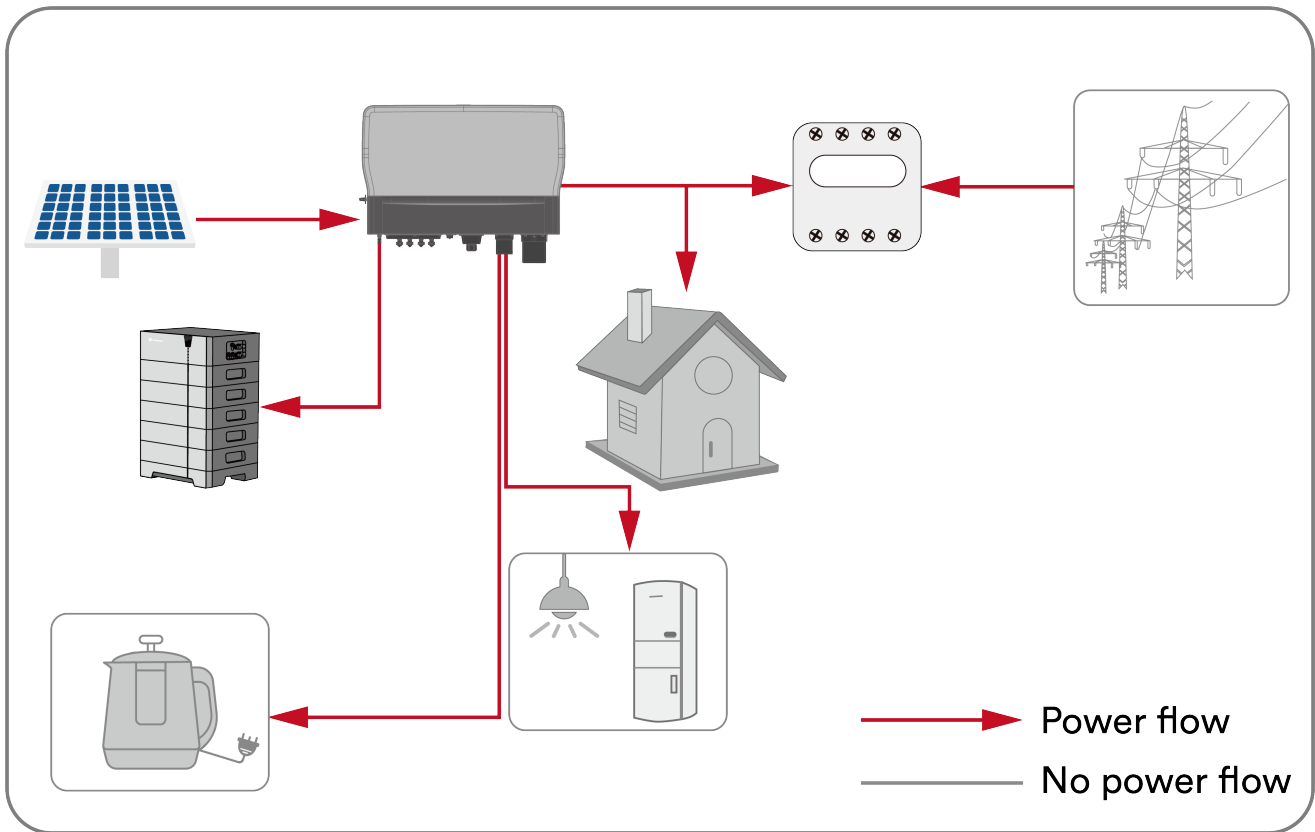

### Off-grid mode

The product operates as a stand-alone inverter. Power is only supplied via the EPS port. No loads shall be connected to the normal AC output terminal.

### Custom mode

Users can manage the system according to their own needs, and set daily regular charging and discharging schedules via the app. Outside of the schedules, the system operates in self-consumption mode.

### Time of use mode

If the user chooses load first, then the inverter will operate in self-consumption mode when the grid charge is disabled. If grid charge is enabled, then the inverter will operate in back-up mode (battery SOC below the set point) or self-consumption mode (battery SOC above the set point).

If the user chooses battery first, the PV power will first charge the battery when grid charge is disabled. If grid charge is enabled, the inverter will operate in back-up mode (when battery SOC is below the set point) or self-consumption mode (when battery SOC is above the set point).

## 4.7 Basic system solution

The product is a high-quality inverter that converts solar energy to AC power and stores excess energy production in a battery. It optimizes self-consumption, enables energy storage for future use, and supports grid feed-in. A diesel generator interface allows a generator to charge batteries and power the loads connected to the EPS port.

The basic application of this product is as follows:

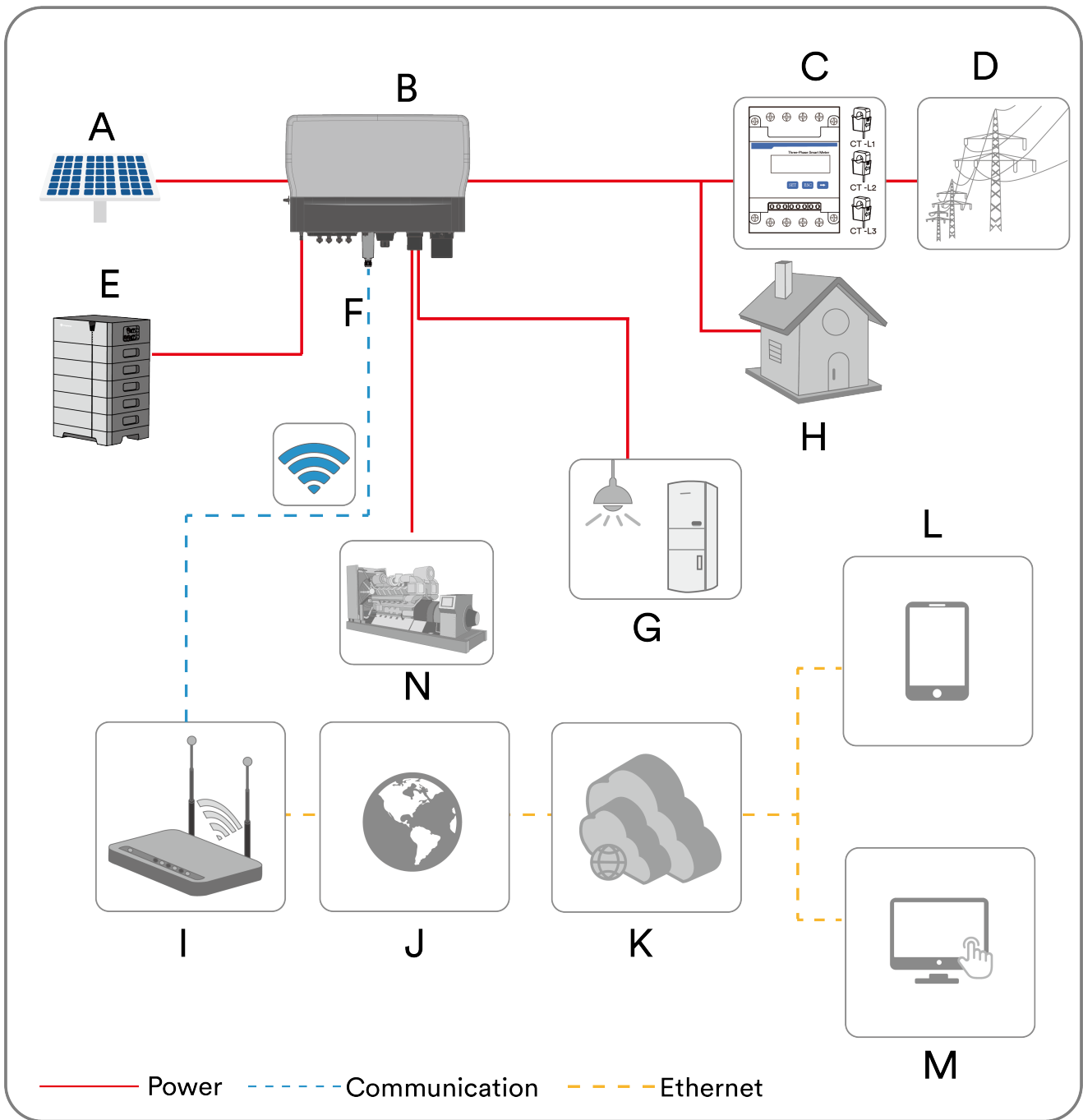

NO	Description	Remark
A	PV array	The product can connect to monocrystalline and polycrystalline silicon based PV modules and thin-film modules that require no functional grounding.
B	Hybrid inverter	ASW015-020K-TH series products have one battery (BAT) port. ASW025-030K-TH series products have two BAT ports.
C	Smart Meter(CTs included)	The smart meter(CHINT DTSU666)measures the power at the point of connection. The smart meter also can be replaced by three current transformers (Reserved)which connect directly to the inverter.
D	Utility grid	The product can connect to TN and TT grid network types.

E	Battery system	The product must only be operated in connection with an intrinsically safe lithium-ion battery system approved by Solplanet.
F	Ai-Dongle	The Ai-Dongle supports ethernet and WLAN communication. It is not recommended to use both communication methods at the same time.
G	EPS Load	The EPS loads directly connect to the EPS port of the inverter. The EPS loads can be supplied with power from the inverter when there is a grid failure.
H	Normal load	The loads which are directly connected to the utility grid. The normal load will not be supplied with power when there is a grid failure.
I	Router	The product can connect to a router via Wi-Fi or an ethernet cable.
J	Internet	The inverter and battery data is sent to the Solplanet Cloud via the Internet.
K	Cloud server	The inverter and battery data is stored on the Solplanet cloud server.
L	Smart Mobile Device	The Solplanet app can be installed on a smart mobile device to view the PV plant information.
M	Computer	The inverter and battery data can also be viewed via a computer which is logged into the Solplanet cloud desktop web application.
N	Diesel generator	The product can connect to diesel generator. Batteries can be charged and EPS loads can be supplied by the diesel generator.

The system diagram of this product as follow:

For Australia and New Zealand, the neutral cable of the On-grid side and EPS side must be connected together according to the wiring rules AS/NZS 3000, otherwise the EPS function will not work.

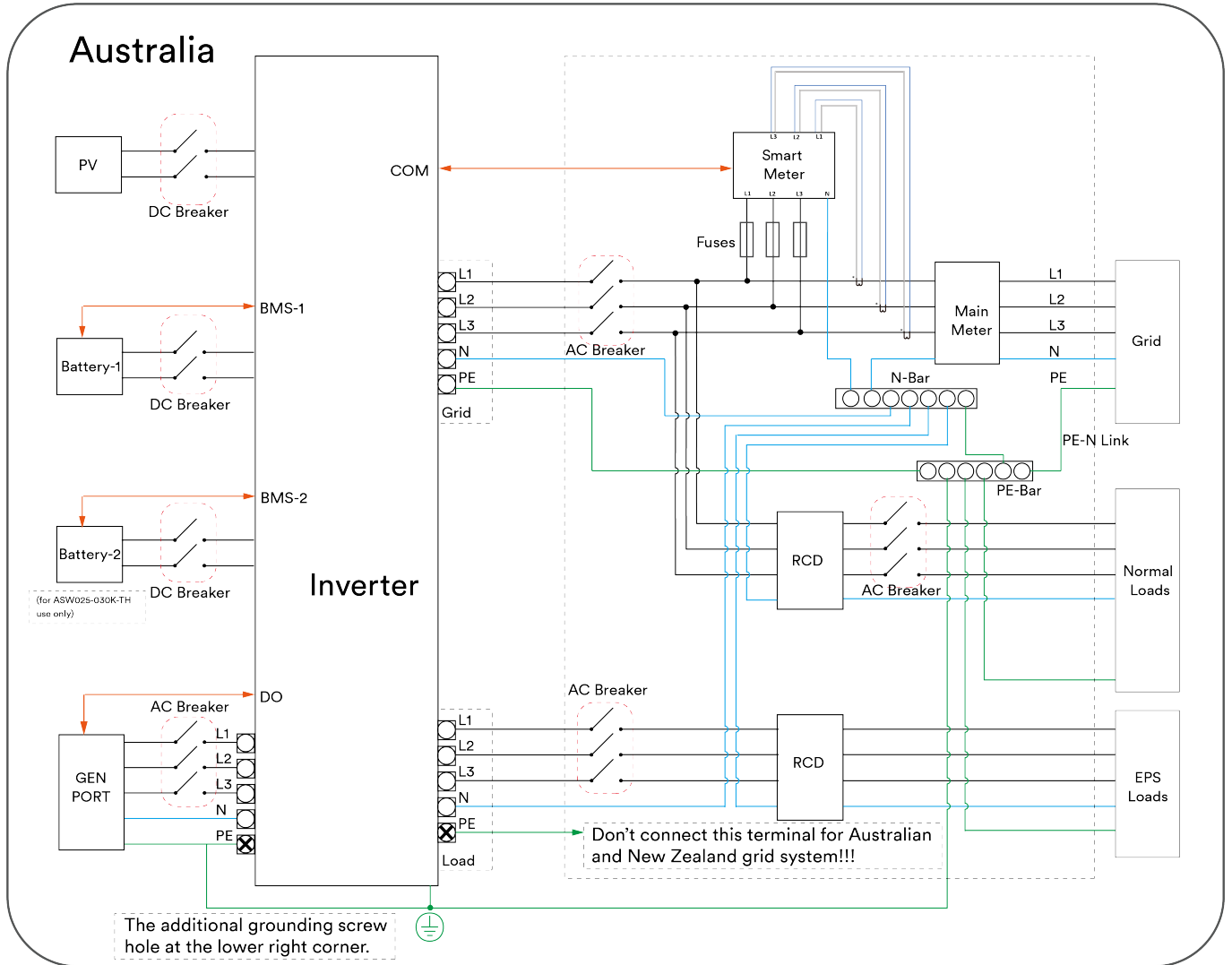

For other countries, the following diagram is an example for grid systems without special requirement on wiring connection.

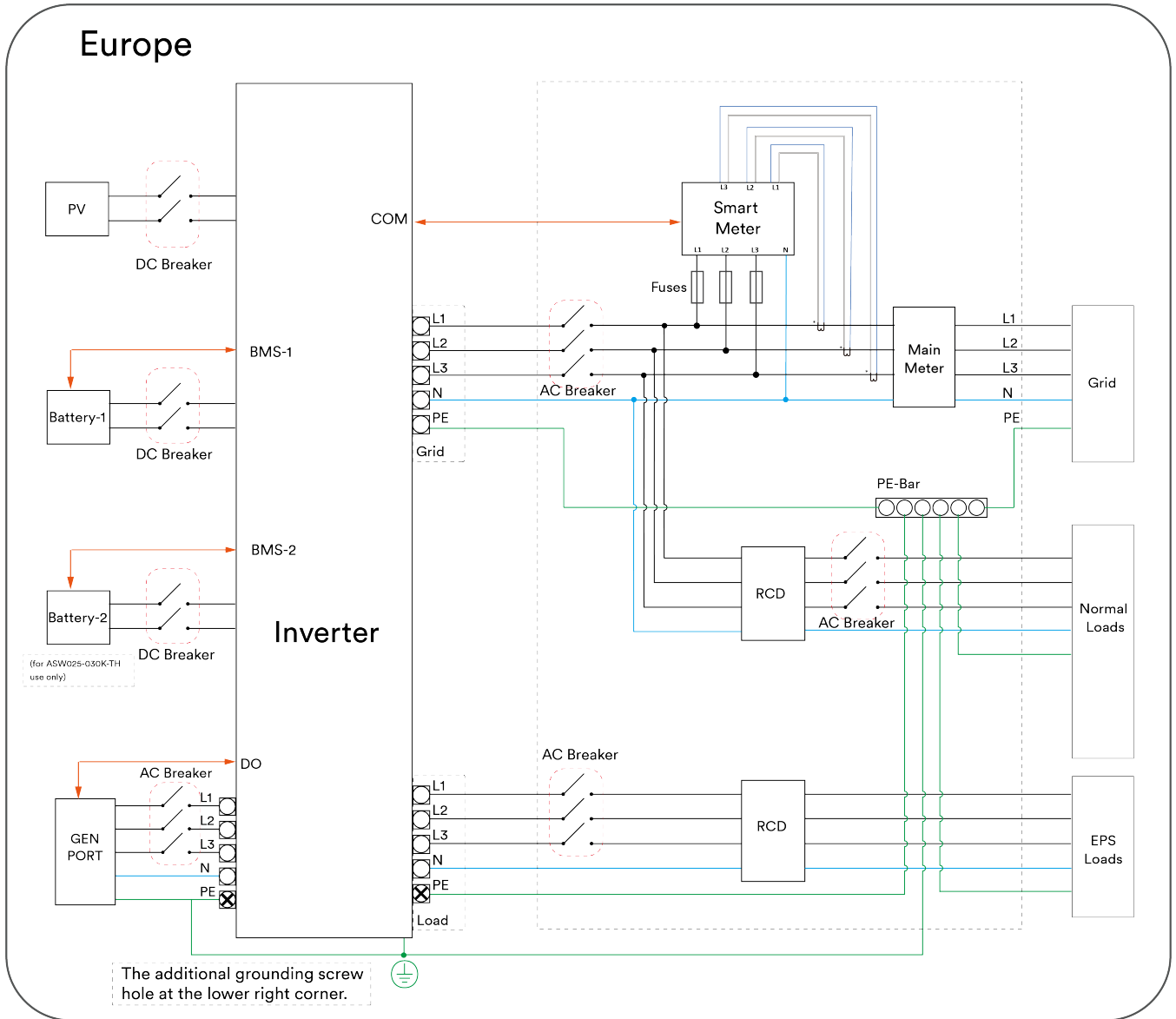

## The wiring of smart meter:

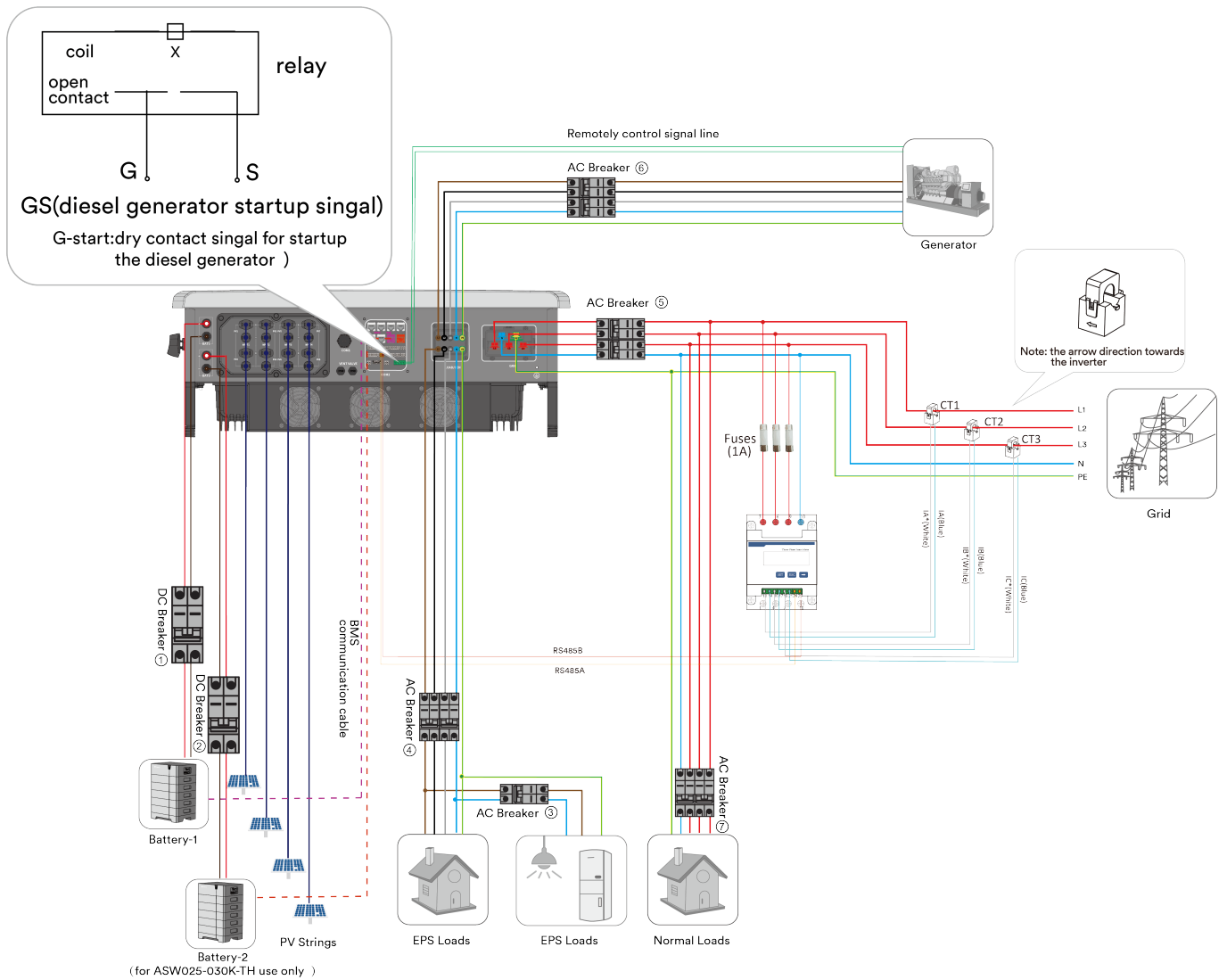

Breaker No.	ASW015K-TH	ASW020K-TH	ASW025K-TH	ASW29.9K-TH	ASW030K-TH
1	63 A/1000 V DC Breaker		63 A/1000 V DC Breaker		
2	/	/			
3	63 A/400 V AC Breaker		100 A/400 V AC Breaker		
4					
5					
6					
7	Dependent on the normal loads which should be checked by an installer				

## 4.8 Parallel System

### 4.8.1 Grid Parallel

The hybrid inverter can operate as a parallel system. The system can even work when the utility grid is loss occasionally.

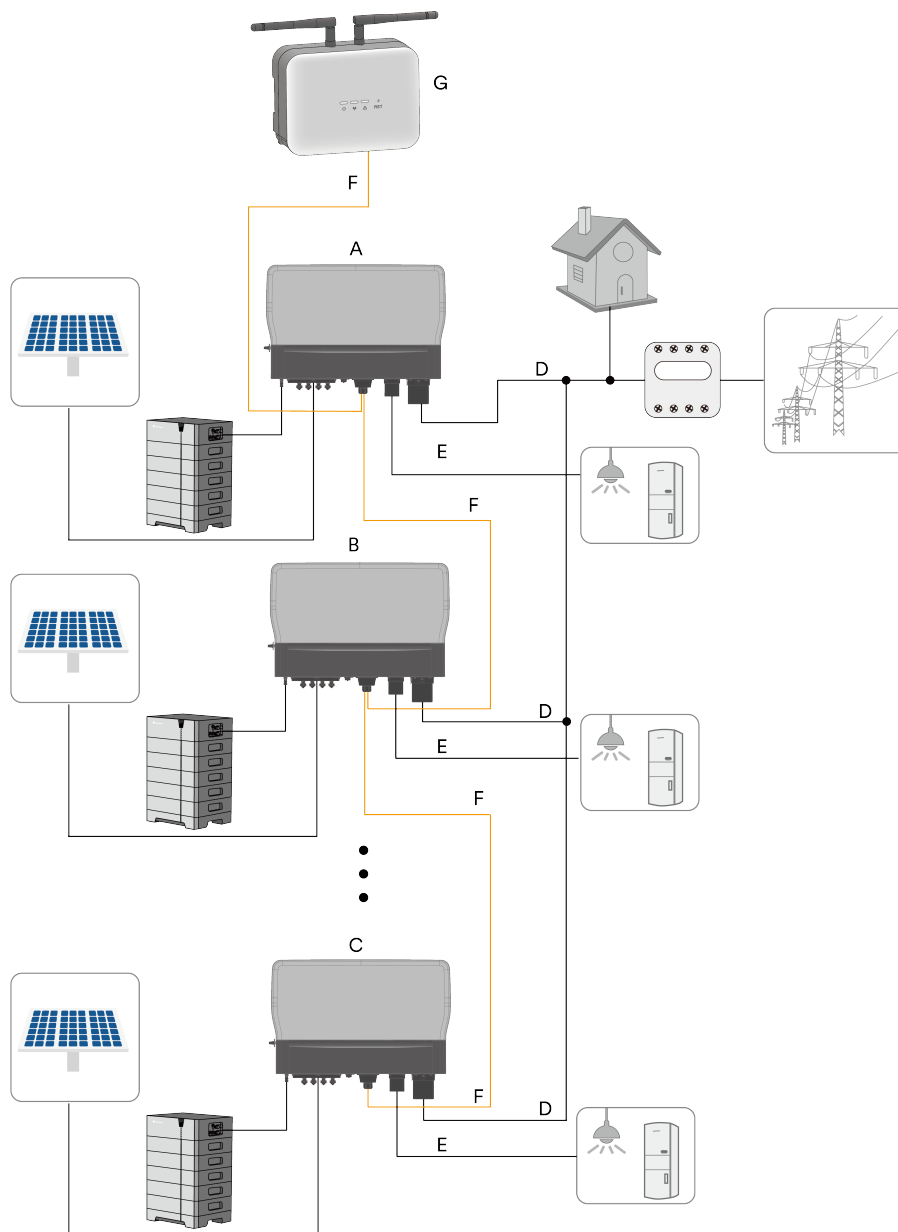

A Inverter 1	B Inverter 2	C Inverter N ( $N \leq 5$ )
D Grid port	E EPS load port	F Communication cable
G Ai-hub		

In the current version, hybrid inverters with the same model can be connected in parallel in grid port. The EPS load should be independent of each inverter and the battery should be same model, show as follows.

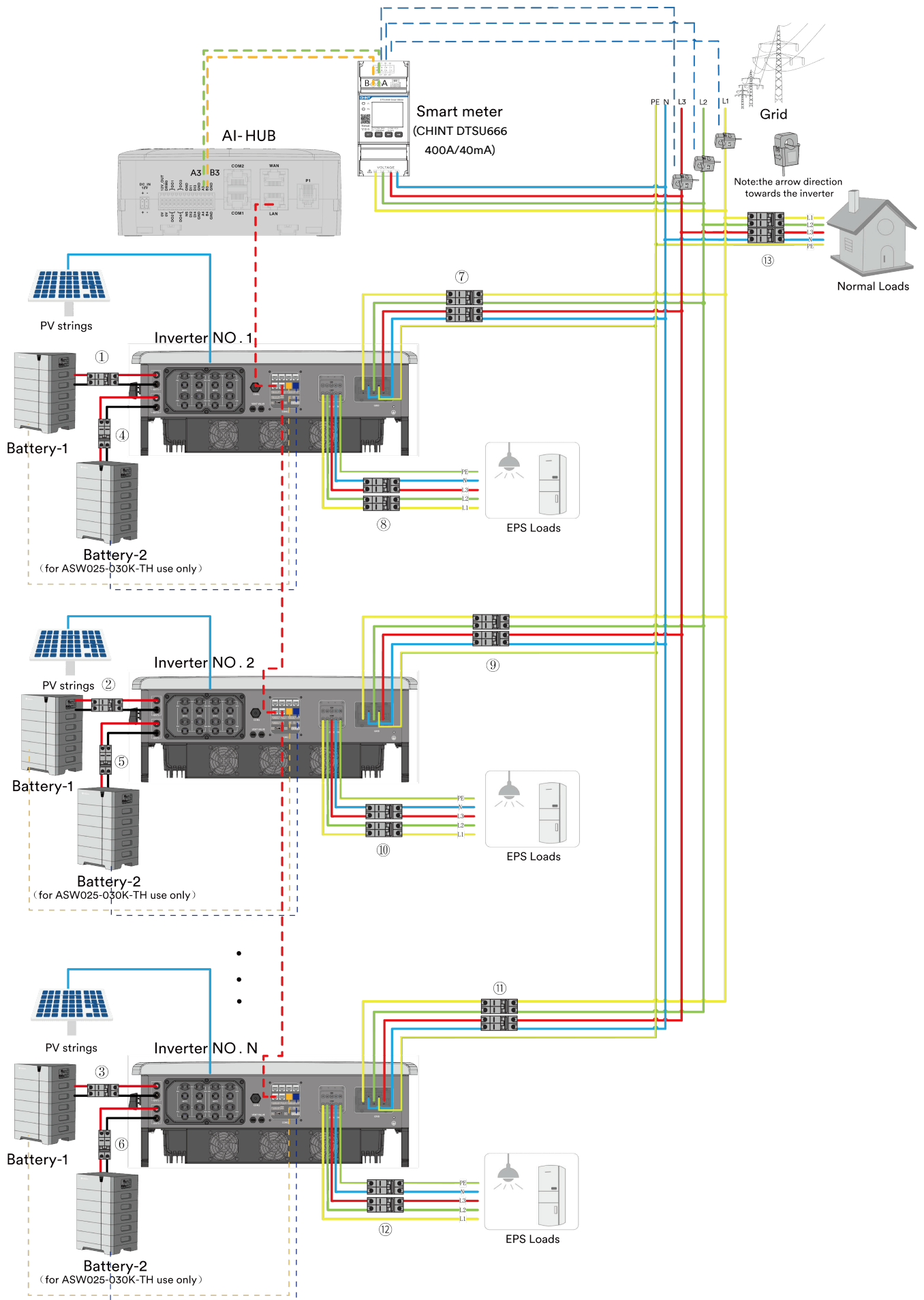

Breaker No.	ASW015K-TH	ASW020K-TH	ASW025K-TH	ASW29.9K-TH	ASW030K-TH
1-3	63 A/1000 V DC Breaker		63 A/1000 V DC Breaker		
4-6	/	/			
7-12	63 A/400 V AC Breaker	80 A/400 V AC Breaker	100 A/400 V AC Breaker		
13	Dependent on the normal loads which should be checked by an installer				

The parallel system supports the following meters. Customer can install the different type of meters which can meet AC bus current requirement. The smart meter should connect as 3P4W wiring refer to smart meter User Manual. Recommend purchasing smart meter from Soplanet, some functions will be limited if purchased from other sources.

Manufacturer	Model	Max current	CTs
CHINT	DTSU666 3*220/380V 250A/50mA 115200bps	250A	3*CT NCTK-24 250A/50mA
CHINT	2.5P DTSU666 3*220/380V 400A/40mA 115200bps	400A	3*CT NCTK-36 400A/40mA

## NOTICE

### Damage to the inverter due to wiring error.

Parallel system wiring must be performed as required, otherwise the product will not work properly or even be damaged.

- The phase sequence of the grid-side wiring of all parallel inverters must be completely consistent.
- The smart meter is connected to the AC bus, that is, when multiple units are running in parallel, the system share one smart meter, and the smart meter communication line is connected to the AI-HUB. The entire parallel system can only use one meter.
- Use Ethernet cables for inverter communication to connect multiple inverters in series. The length of a single Ethernet cable should less than 20m. The wire sequence is the same at both ends of the Ethernet cable, the two communication cables cannot be confused.
- AI-HUB can uniformly set the working mode and battery SOC of all connected hybrid inverters, and the battery brand and battery module qty need to be clicked into each inverter for setting. Please refer to Chapter 8.4.
- Adding inverters or deleting inverters in the parallel system requires re-scanning the inverter. After adding a new inverter, the Settings need to be reset.

## 5 Mounting

### 5.1 Requirements for mounting

#### **DANGER**

##### Danger to life due to fire or explosion!

Despite careful construction, electrical devices can cause fires. This can result in death or serious injury.

- Do not mount the product in areas containing highly flammable materials or gases.
- Do not mount the inverter in areas where there is a risk of explosion.
- To ensure optimal operation, an ambient temperature below 60°C is recommended.
- A solid support surface must be available (e.g., concrete or masonry). Ensure that the installation surface is solid enough to bear four times the weight of the inverter. When mounted on drywall or similar materials, the product may emit audible vibrations during operation.
- The mounting location must be inaccessible to children.
- The mounting location should be freely and safely accessible to authorised personnel at all times without the need for any auxiliary equipment (such as scaffolding or lifting platforms). Non-fulfillment of these criteria may impede servicing and system troubleshooting.
- Do not expose the mounting location to direct solar irradiation. Exposure to direct solar irradiation can cause the exterior plastic components to age prematurely and may result in overheating. Under high temperatures, the product will reduce its power output accordingly to avoid overheating.

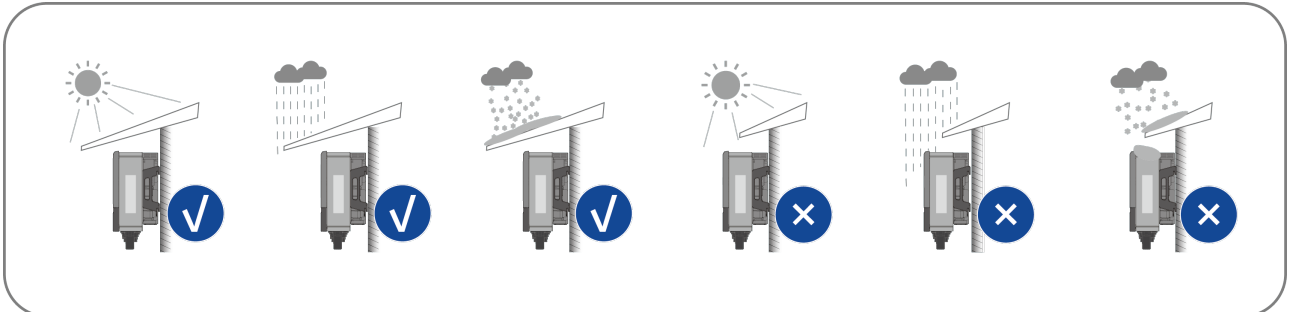

- Never install the inverter horizontally, or with a forward / backward tilt or even upside down. Horizontal installation can lead to damage to the inverter.

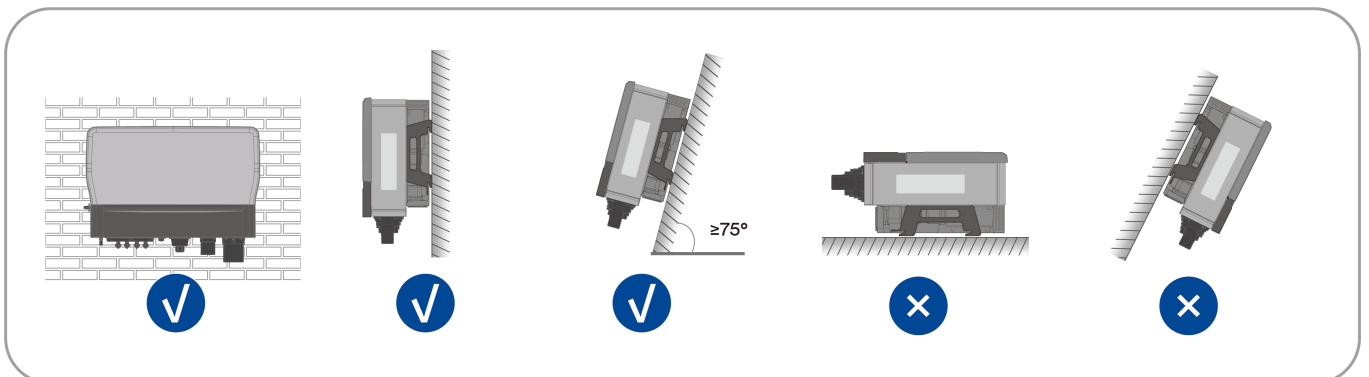

- Maintain the recommended clearances to other walls and to other inverters or objects.

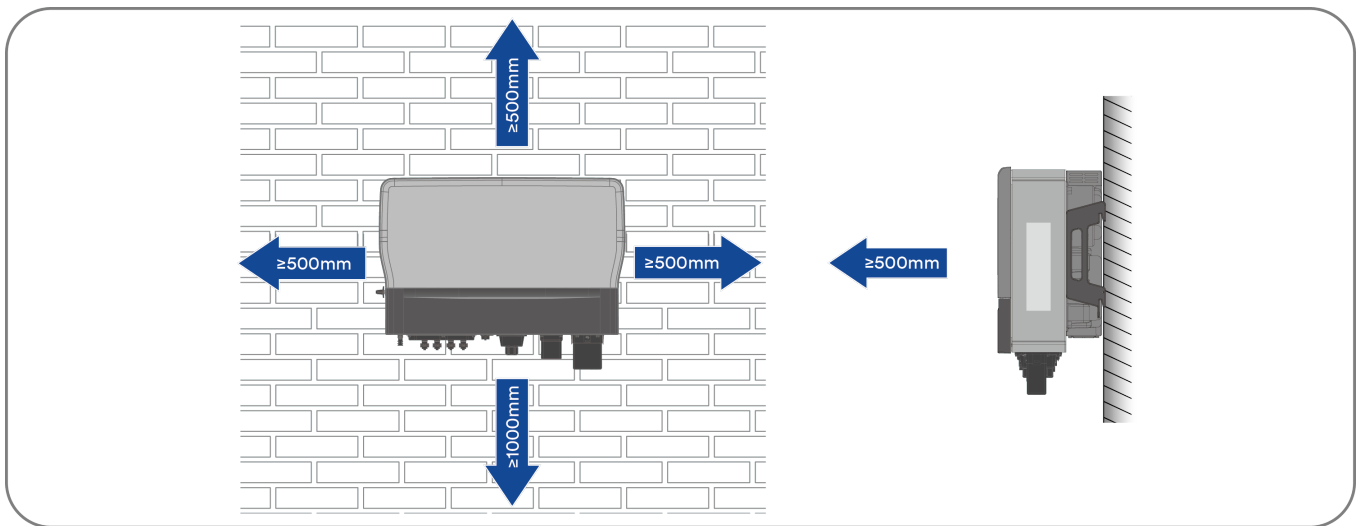

- In case of multiple inverters, reserve the specific clearance requirements between the inverters.

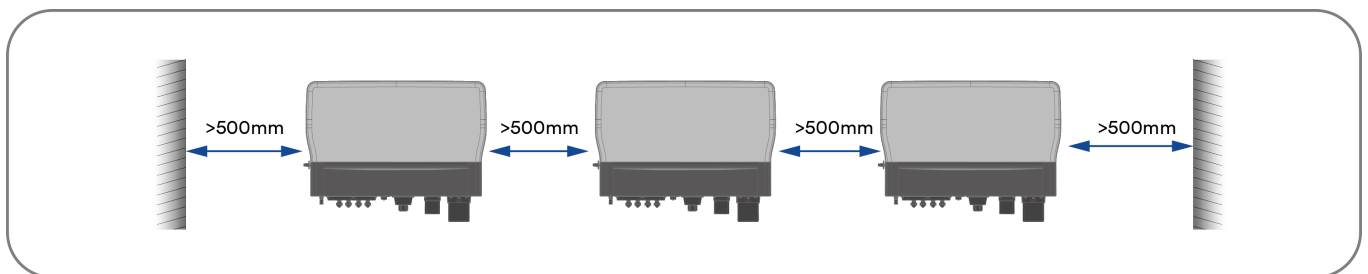

- Mount the product in a way that allows for easy recognition and reading of the LED signals.
- The DC switch of the product must always be readily accessible.

## 5.2 Taking out and moving the product

Open and remove the inverter out of the packaging, and place at the designated installation location.

### CAUTION

#### Risk of injury due to the weight of the product!

The net weight of this product is 50.5~58 kg. Incorrectly lifting the inverter during installation could cause it to fall, leading to injury or equipment damage.

- Transport and lift the product carefully. Take the weight of the product into account.
- Wear suitable personal protective equipment for all work on the product.

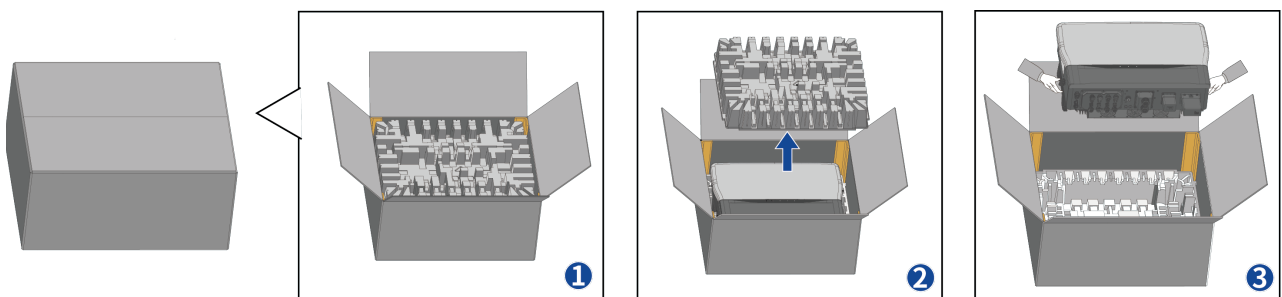

## 5.3 Mounting



### CAUTION

**Danger of personal injury due to falling inverter!**

If the hole depth and distance are not correct, the inverter may fall off the wall.

- Before inserting the bolts into the wall, measure the depth of the hole.



### CAUTION

**Damage to electrical cables and utility service lines can cause personal injury!**

Electrical cables or utility service lines (gas or water) may be mounted externally on walls.

- Ensure no cables or utility service lines mounted on the wall or inside the wall cavity are damaged when drilling.

**Step 1:** Remove the mounting bracket template from the accessory bag and place the template horizontal to the wall with the arrow facing up. Mark the drilling position. Remove the template and drill the marked hole with a diameter of 12 mm. Drill to a depth of approximately 70 mm. Maintain the hammer drill perpendicular to the wall during drilling.

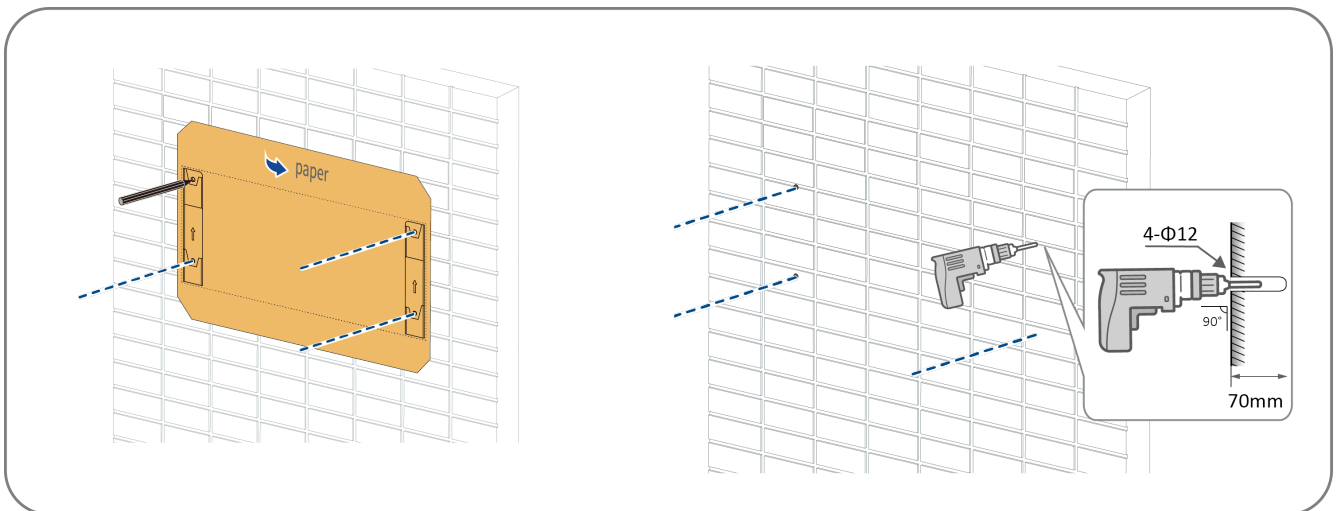

**Step 2:** Remove any dust from the hole, insert four expansion bolts into the hole, gently tap them into the hole with a rubber hammer. Fix the bolt tail, and remove the nut, spring washer and flat washer and reserve them for the next step.

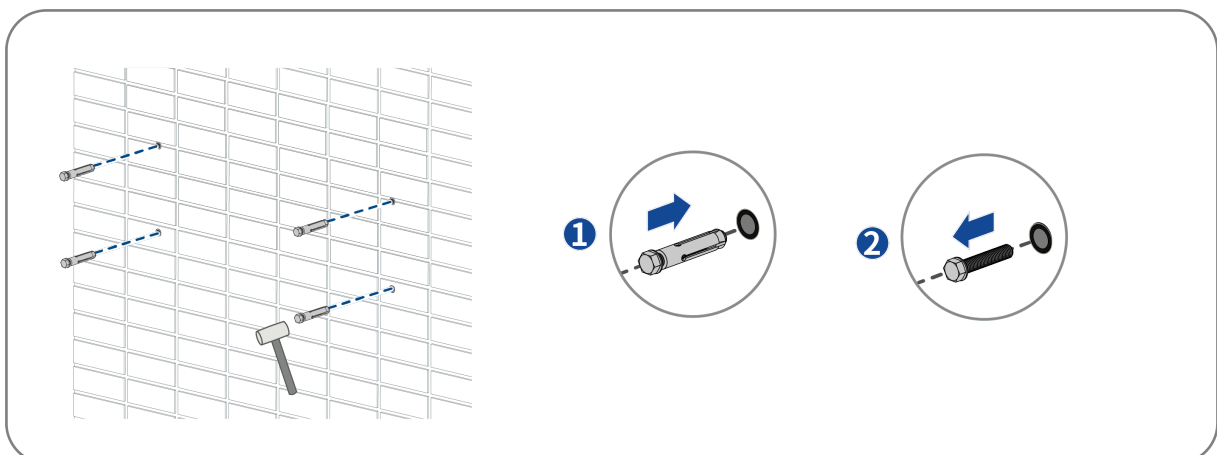

**Step 3:** Fix the mounting bracket using the expansion bolts.

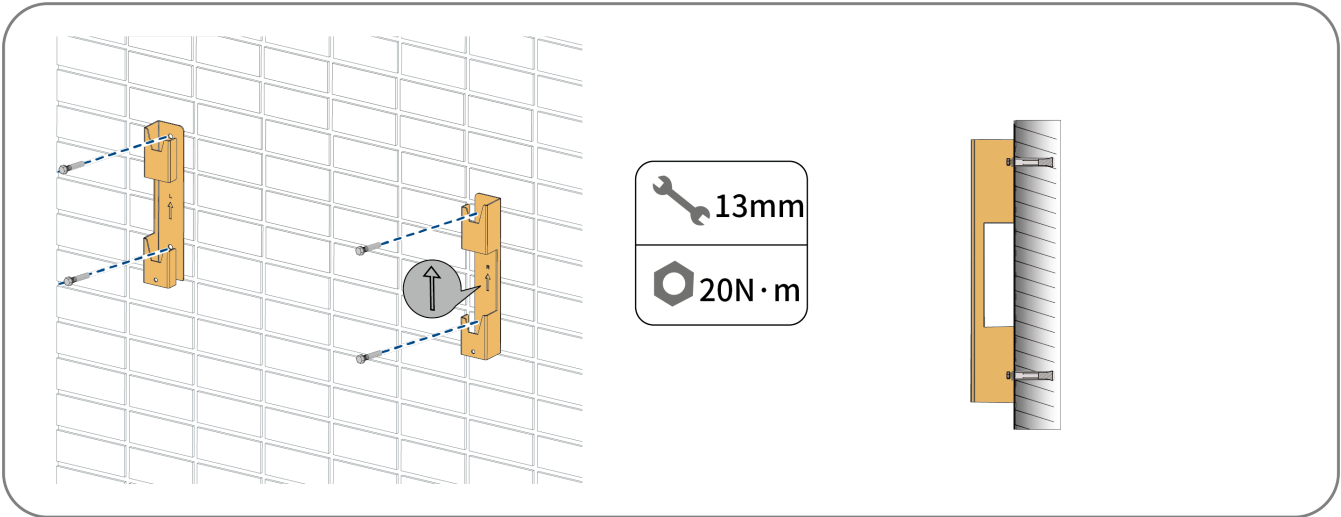

**Step 4:** Lift and place the inverter onto the mounting-bracket and ensure that the mounting flanges perfectly align with the mounting bracket.

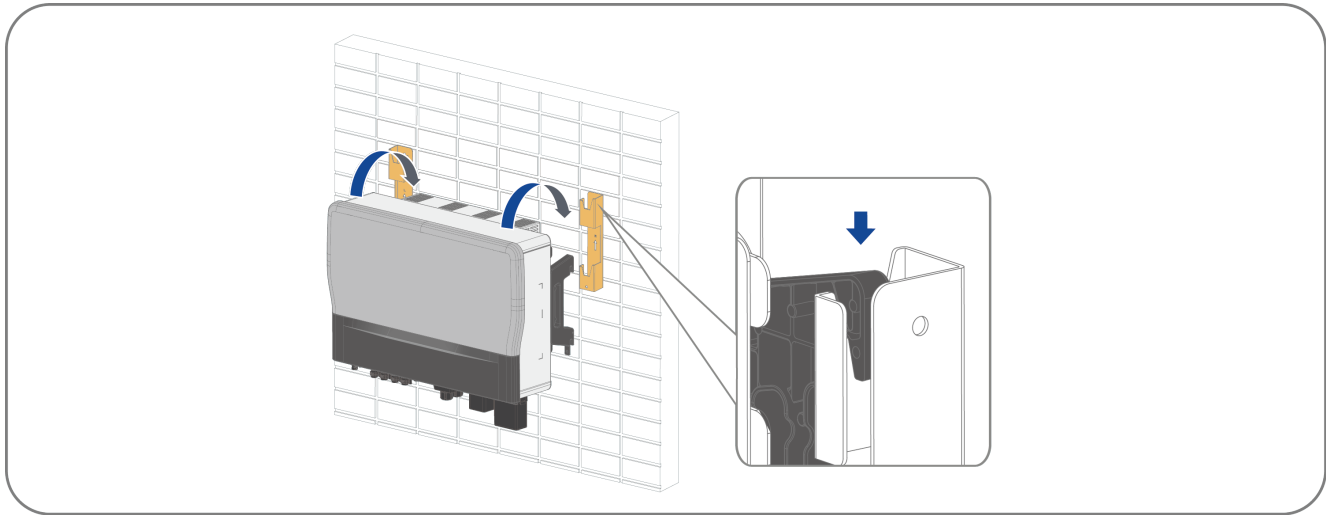

**Step 5:** Secure the inverter by inserting screws into the threaded security hole. The inverter has an added anti-theft feature which allows the placement of anti-theft lock if required.

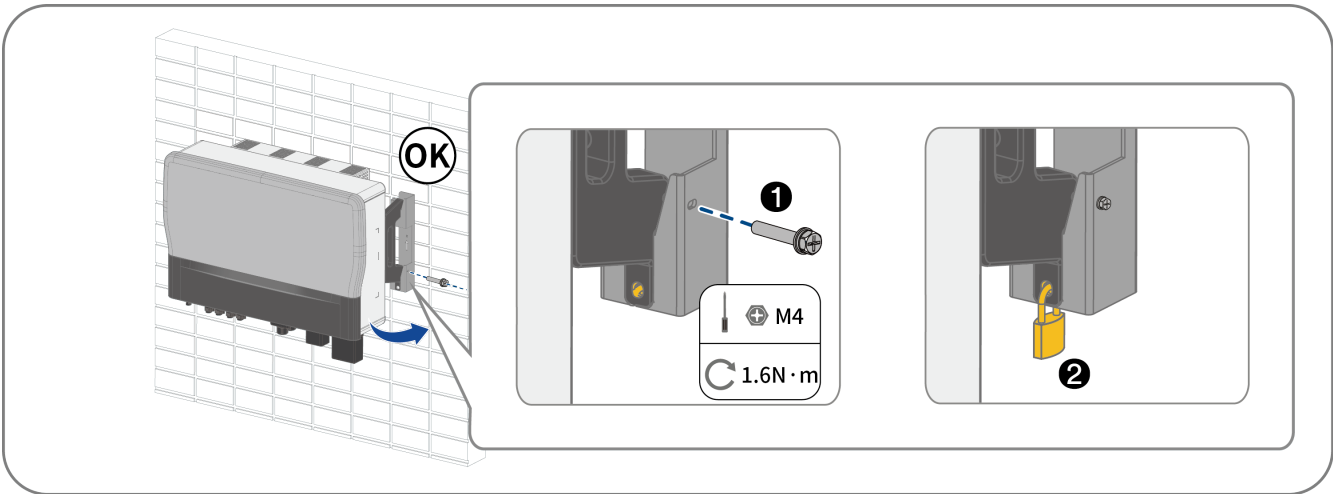

**Installation complete.**

## 6 Electrical connection

### 6.1 Connection Interface Description

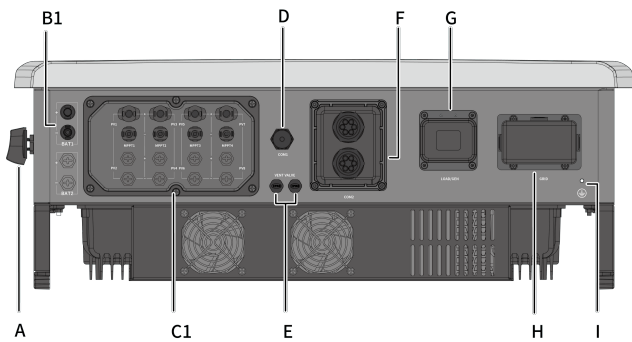

ASW015-020K-TH (left)

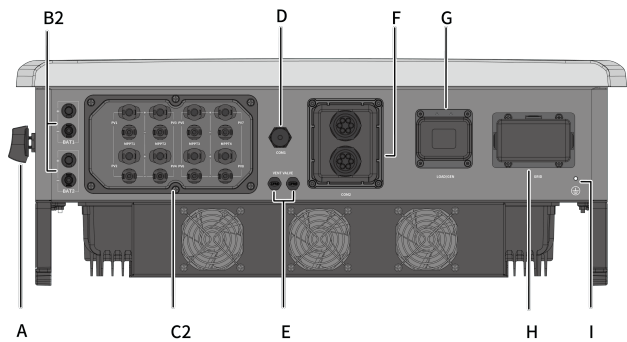

ASW025-030K-TH (right)

Item	Description
A	DC-Switch
B1/2	Battery Connector Port
C1/2	PV Input
D	Ai-Dongle Port
E	Ventilation valve Port
F	Communication Ports
G	Diesel Generator Connector Port
	EPS Load Connector Port
H	AC Connector Port
I	Additional Grounding Screw

### 6.2 Connecting additional grounding

The inverter is equipped with a residual current monitoring unit (RCMU). The RCMU detects when there is no grounding conductor connected and disconnects the inverter from the utility grid if this is the case. Hence, the product does not require an additional grounding or equipotential bonding when operating.

If the grounding fault monitoring function is deactivated or the additional grounding is required by locally standard, you can connect additional grounding to the inverter.

#### Requirements for the secondary protection ground cable:

Item	Description	Note
1	Screw	M5, supplied
2	OT/DT terminal	Specifications M5, provided by the customer
3	Yellow and green ground cable	Same as the PE wire in the AC cable.

**Procedure:**

**Step 1:** Strip the grounding cable insulation. Insert the exposed section of the grounding cable into the ring terminal lug and crimp using a crimping tool.

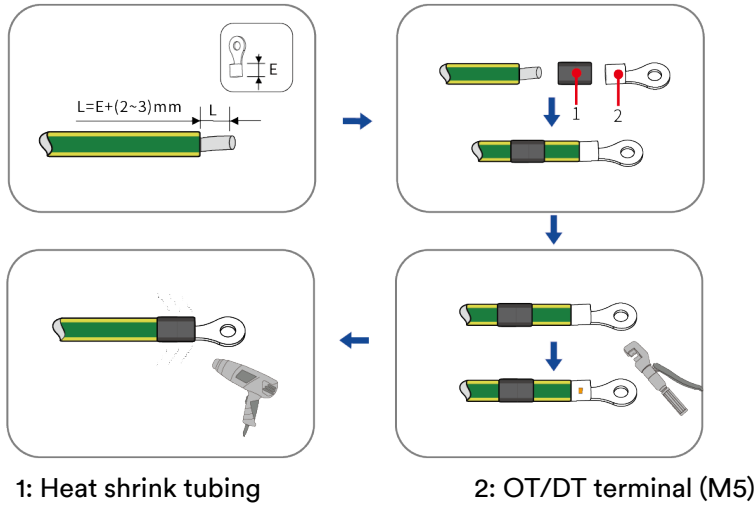

**Step 2:** Remove the screw on the ground terminal, insert the screw through the OT/DT terminal, and tighten the screw onto the terminal using a screwdriver.

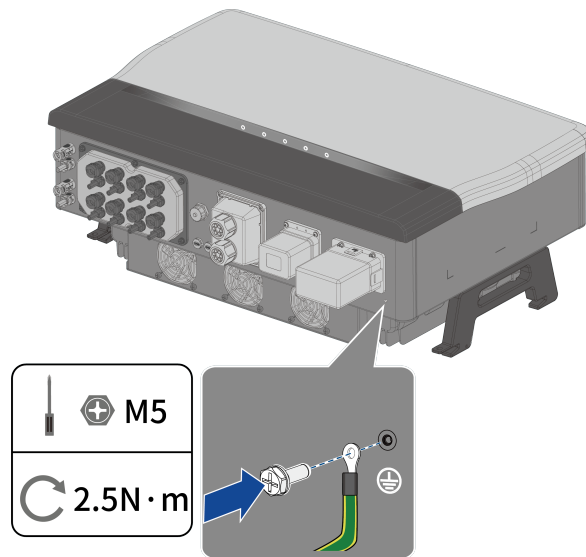

**Step 3:** Apply paint to the grounding terminal to ensure corrosion resistance.

**Installation Complete.**

## 6.3 Grid AC connection

### 6.3.1 Requirements for AC Grid connection

The cable must be dimensioned in accordance with the local and national directives for the dimensioning of cables. The requirements for the minimum wire size derive from these directives. Examples of factors influencing cable dimensioning are: nominal AC current, type of cable, routing method, cable bundling, ambient temperature and maximum desired line losses.

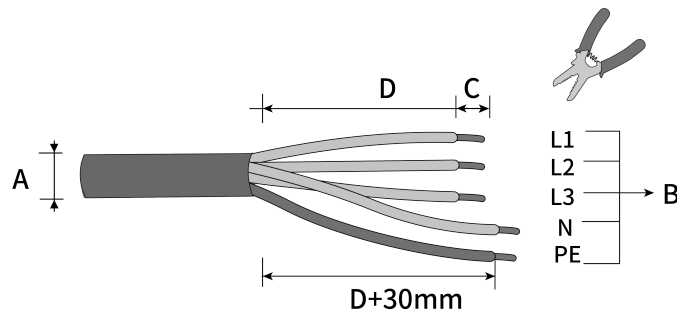

Item	Description	Value
A	External diameter	16...35 mm
B	Copper cable conductor cross-section	16~50 mm <sup>2</sup>
C	Insulation stripping length	Meeting OT/DT terminal specification
D	Sheath stripping length	130 mm

**Requirements for M8 OT/DT Terminal**

OT/DT terminals (not included in the delivery scope) are required for connecting AC cables to the terminal block.

Purchase the OT/DT terminals according to the following requirements.

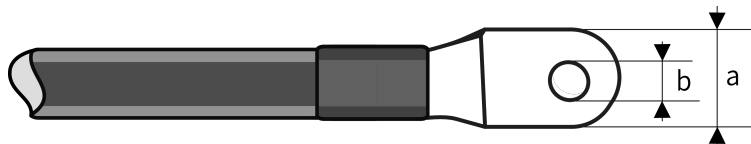

Item	Description
A	$a \leq 22 \text{ mm}$
B	$8.5 \text{ mm} \leq b \leq 10.5 \text{ mm}$

**i**

Ensure that the selected cable lug makes direct contact with the copper wire. If there are any problems, contact the manufacturer of the terminal.

Direct contact between the copper bar and the aluminium cable will cause electrochemical corrosion and impair the reliability of electrical connection.

**Residual current protection**

The product is equipped with an integrated universal current-sensitive residual current monitoring unit inside. Hence, the product does not require an external residual current device (RCD) when operating.

**i**

If local regulations require the use of an RCD, please install a type A RCD with a protection limit of not less than 300 mA.

## Overvoltage category

The inverter can be used in grids of overvoltage category III or lower in accordance with IEC 60664-1. This means that the product can be permanently connected to the grid-connection point of a building. In case of installations with a long outdoor cable route, additional measures to reduce overvoltage category IV to overvoltage category III are required.

## AC circuit breaker

In PV systems with multiple inverters, protect each inverter circuit with a dedicated circuit breaker. The circuit breaker will also provide a point of isolation to allow electrical work to be carried out during installation or maintenance. Please refer to the local electrical regulations for further information.

Avoid connecting any consumer load between the AC circuit breaker and the inverter.

The selection of the AC circuit breaker rating is dependent on the wiring design (wire cross-section area), cable type, wiring method, ambient temperature, inverter current rating, etc. Derating of the AC circuit breaker rating may be necessary due to self-heating or if exposed to heat.

The maximum output current and the maximum output overcurrent protection of the inverters can be found in section 10 "Technical data".

## Ground fault monitoring

The inverter is equipped with a grounding fault monitoring device. This grounding fault monitoring device detects when there is no grounding fault connected and disconnects the inverter from the utility grid if this is the case. Depending on the installation site and grid configuration, it may be advisable to deactivate the grounding fault monitoring. This is necessary, for example, in an IT system if there is no neutral conductor present and you intend to install the inverter between two line conductors. If you are uncertain about this, contact your grid operator or Solplanet.



### Safety in accordance with IEC 62109 when the grounding fault monitoring is deactivated.

In order to guarantee safety in accordance with IEC 62109 when the grounding fault monitoring is deactivated, carry out the following measure.

- Connect additional grounding that has at least the same cross-section as the connected grounding conductor to the AC cable. This prevents touch current in the event of the grounding conductor on the AC cable failing.

## 6.3.2 AC cable connection

**Step 1:** Switch off the circuit breaker protecting the inverter circuit and switch off and isolate all energy sources up stream and down stream of the circuit breaker and secure it against inadvertent switch on. Using an appropriately rated multimeter to ensure there is no AC voltage present on each of the terminals on the circuit breaker.

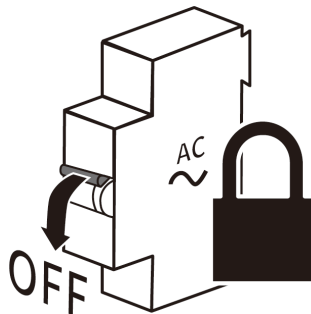

**Step 2:** Remove the AC protective cover from the inverter and take out the AC connector from the accessory kit.

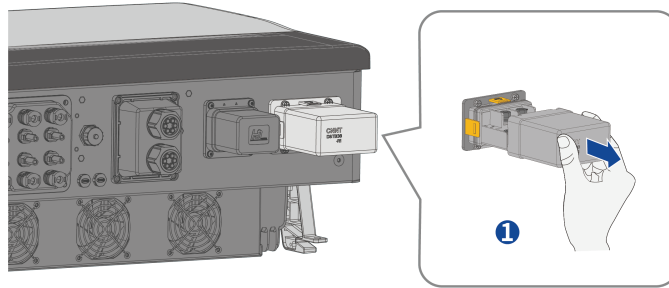

**Step 3:** Remove the cover of the AC connection terminal and select the appropriate sealing ring according to the diameter of the cable.

**Step 4:** Feed the AC cable through the cable fittings.

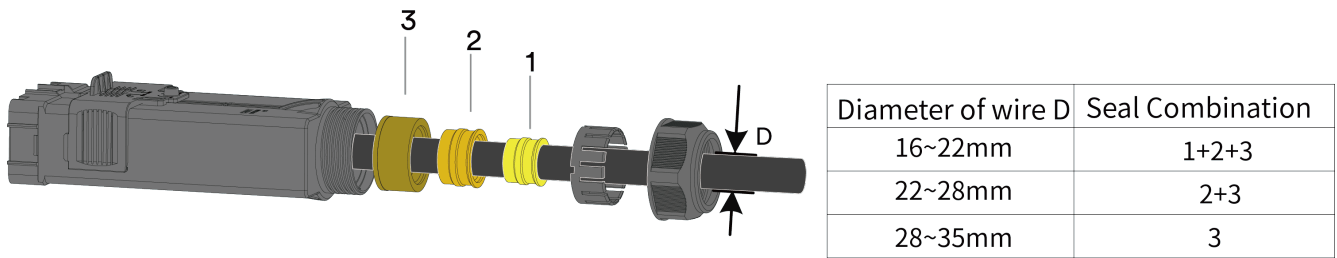

**Step 5:** Strip the insulation from the individual wires for L1 / L2 / L3 / N and PE (ground) so that the wire strands and insulation can be crimped into an OT/DT terminal, reference 6.3.1.

**Step 6:** Guide the heat shrink tubing over the uninsulated crimp point and crimp the OT/DT terminal.

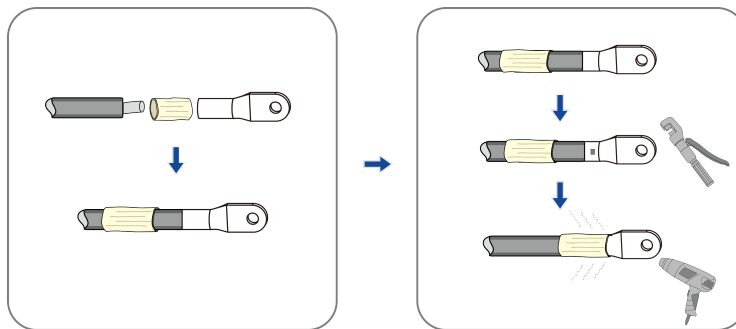

**Step 7:** Lift the cable spacer upwards, loosen the nuts marking the grounding points L1,L2,L3 in reserve, place the holes of the crimped terminals onto the studs of the corresponding terminals, the grounding points are secured with the nuts provided. Lower the spacer to its original position.

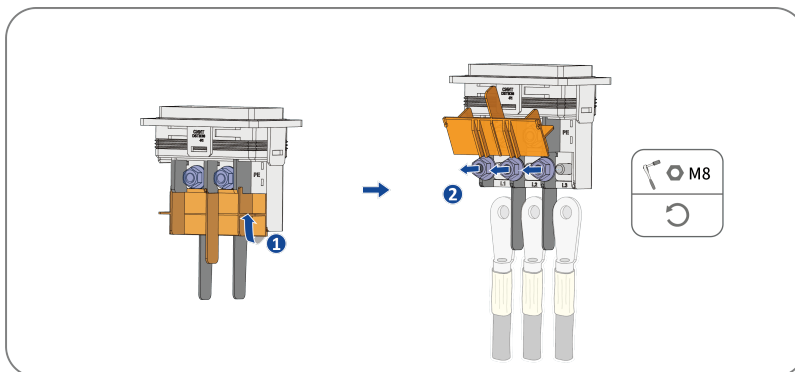

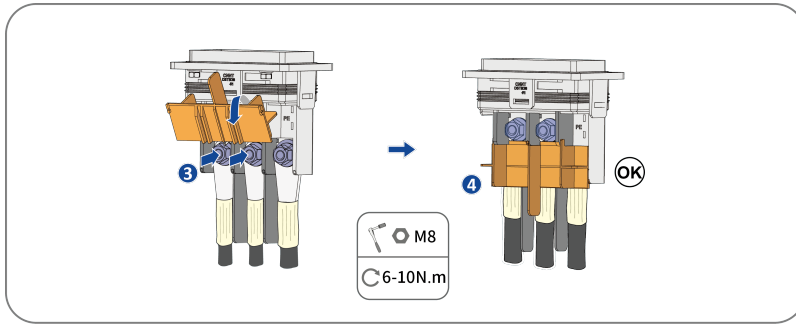

**Step 8:** Loosen the nut marking the grounding point N,PE proceed to lay the round hole of the crimped terminal onto the stud of the corresponding terminal, the grounding point must be secured with the provided nut.

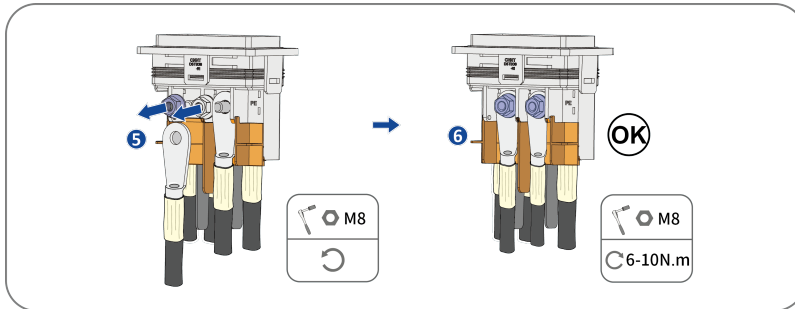

**Step 9:** Gently pull on the cable backwards to ensure the connection is secure.

**Step 10:** Insert the body into the machine end until it “clicks”, then tighten the nut with an open-end wrench.

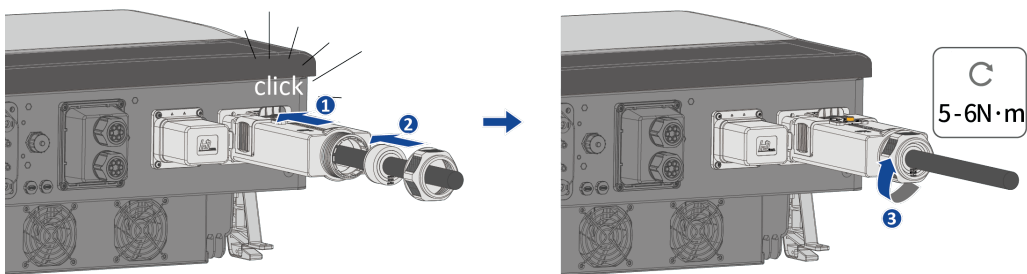

**Step 11:** Push down on the locking mechanism on the AC connector and lock the AC connector box with the screwdriver .

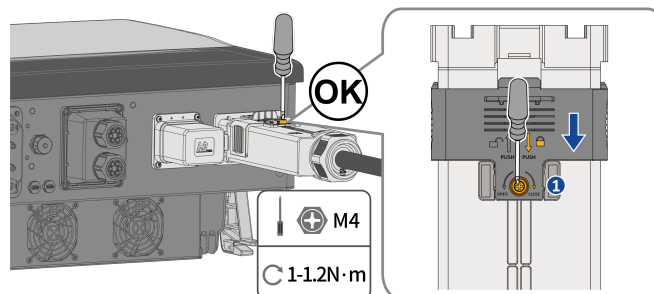

**Complete the installation.**

## NOTICE

The AC connector at customer side has to be tightened and sealed properly regardless if there is no grid connection.

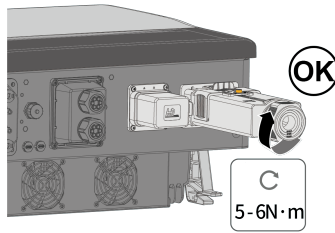

## 6.4 EPS Load / Diesel Generator cable connection

**Step 1:** Switch off the circuit breaker protecting the inverter circuit and switch off and isolate all energy sources up stream and down stream of the circuit breaker and secure it against inadvertent switch on. Using an appropriately rated multimeter to ensure there is no voltage present on each of the terminals on the circuit breaker.

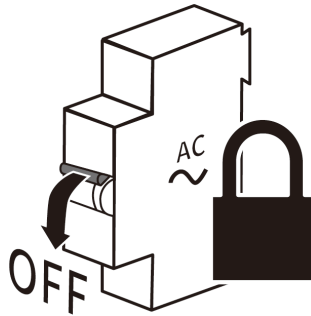

**Step 2:** Remove the LOAD/GEN port protection cover from the inverter and take out the LOAD/GEN connector from the kit.

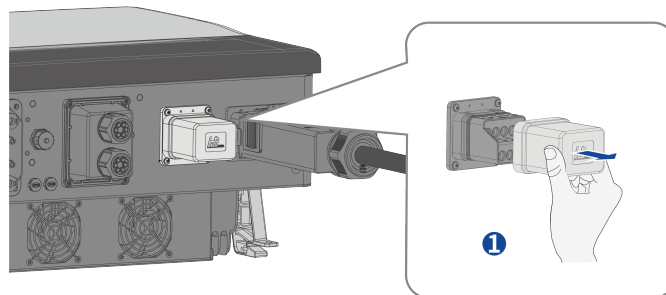

**Step 3:** Unfasten the cable fitting for LOAD /GEN connection, unscrew the cable connector for the load/generator connection, remove the smallest black sealing ring and cut the hole with a tool.

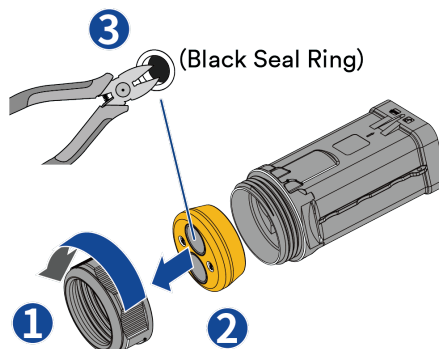

**Step 4:** Load/GEN cable requirements are as follows, stripped as shown.

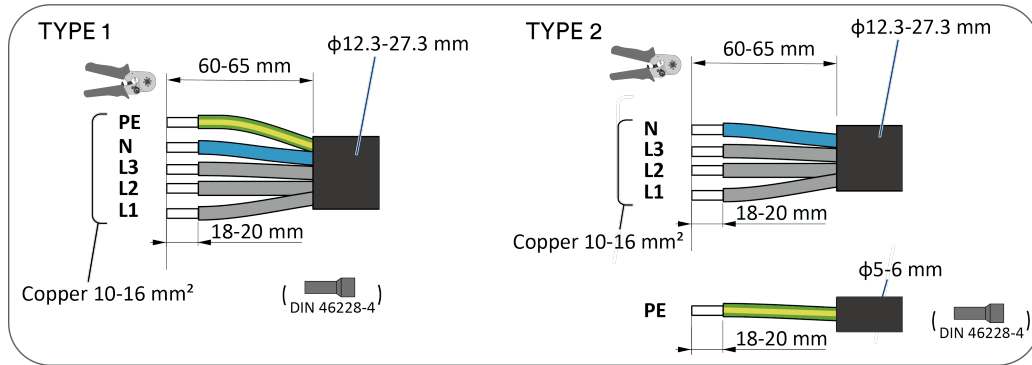

**Step 5:** Feed cable through cable glands, select the appropriate sealing ring according to the wire diameter.

**Step 6:** LOAD/GEN cable requirements: strip as shown, crimp conductors to suitable bootlace ferrule (DIN 46228-4, customer-provided).

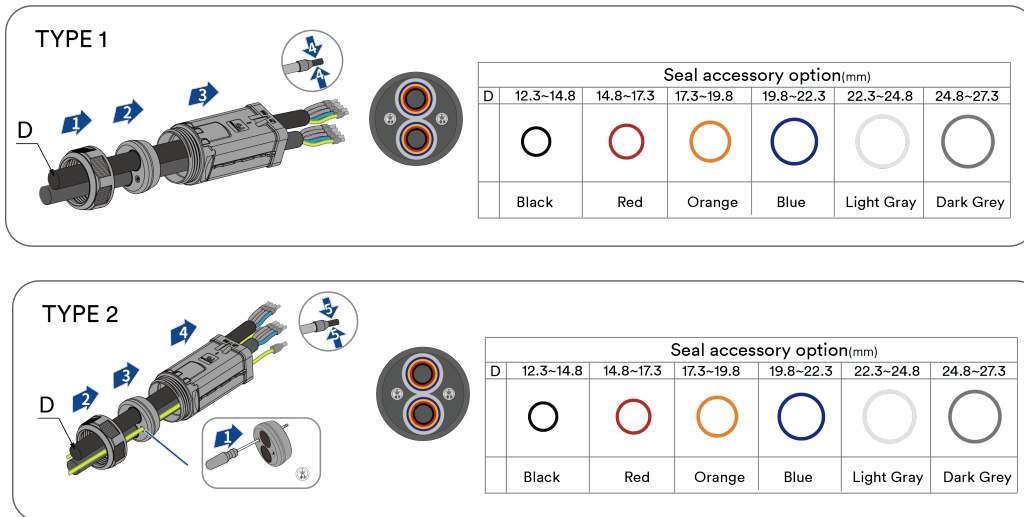

**Step 7:** Insert the ground (PE), neutral (N) and L1, L2 and L3 conductors, using bootlace ferrules when necessary, into the load connector terminal, then into the corresponding connections in the terminal block of the GEN connector in the order shown in the arrows below, and tighten the screws using a hey key. (GEN connections currently)

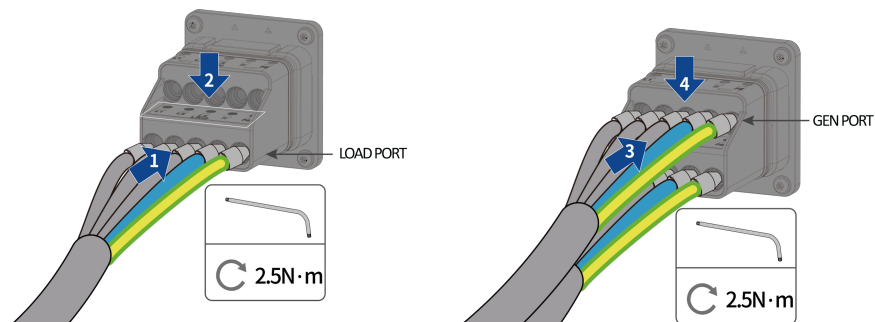

**Step 8:** Insert the body into the machine end until it “clicks”, then tighten the nut with an open-end wrench.

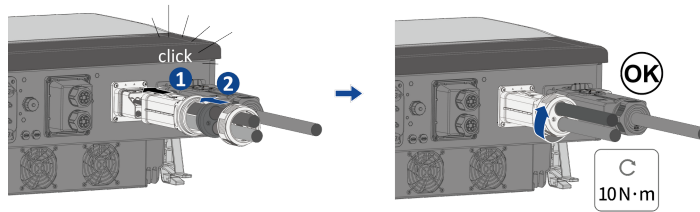

Complete the installation.

## NOTICE

The EPS/Diesel generator connector has to be tightened and sealed properly regardless if there is no load or diesel generator connected.

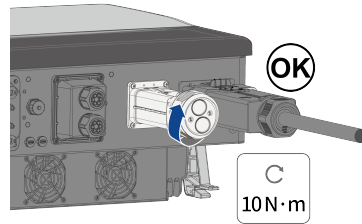

## 6.5 DC Connection

### 6.5.1 Requirements for the DC connection

#### Requirements for the PV modules per input:

- All PV modules in the same string and MPPT should be aligned and tilted identically.
- On the coldest day based on statistical records, the open-circuit voltage of the PV modules must never exceed the maximum input voltage of the inverter.
- Ensure each PV module's input current stays within the DC connectors' max current limits.
- The connection cables to the inverter must be equipped with the connectors included in the scope of delivery.
- The thresholds for the input voltage and the input current of the inverter must be adhered to.
- The positive connection cables of the PV modules must be equipped with the positive DC connectors. The negative connection cables of the PV modules must be equipped with the negative DC connectors.

### 6.5.2 Assembling the DC connectors

#### **DANGER**

**Danger to life due to electric shock when live components or DC cables are touched!**

When exposed to light, the PV modules generate high DC voltage which is present in the DC cables. Touching live DC cables results in death or lethal injuries due to electric shock.

- Do not touch non-insulated parts or cables.
- Disconnect the product from voltage sources and ensure it cannot be reconnected before working on the device.
- Wear suitable personal protective equipment for all work on the product.

Assemble the DC connectors as described below. Be sure to observe the correct polarity. The DC connectors are marked with the symbols “+” and “-”.

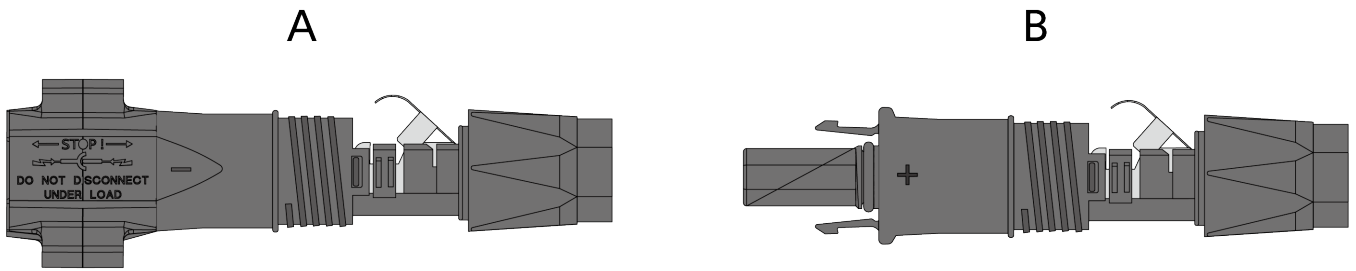

**Cable requirements:**

Item	Description	Value
1	Cable type	PV cable
2	External diameter	5-8 mm
3	Conductor cross-section	2.5-6 mm <sup>2</sup>
4	Number of copper strands	At least 7
5	The rated voltage	≥1100v

**Procedure:**

**Step 1:** Strip 12 mm of cable insulation from the cable.

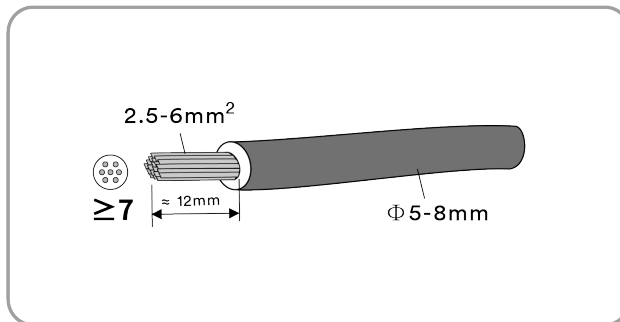

**Step 2:** Guide the cable into the connector housing and push down on the wire clamp. A “click” sound is heard when the wire clamp is correctly secured.

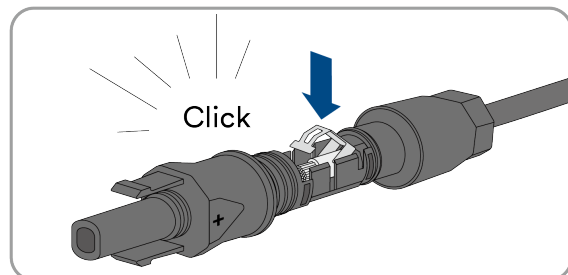
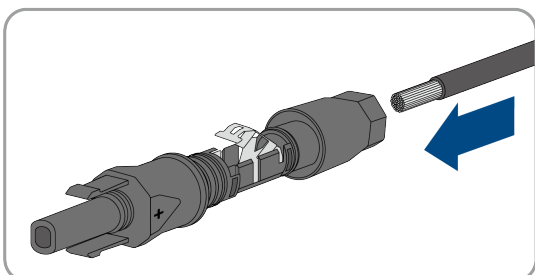



If the stranded wire is not visible in the chamber, the cable is not correctly inserted and the connector must be reassembled. To do this, the cable must be removed from the connector.

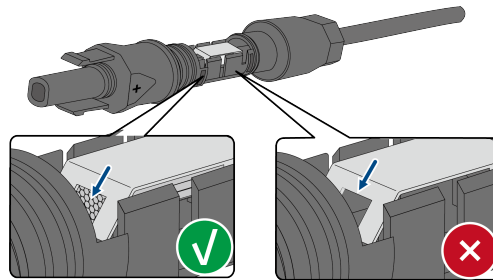

Release the wire clamp. To do so, insert a screwdriver (blade width: 3.5mm) into the wire clamp and pry the wire clamp open.

Remove the cable and go back to step 2.

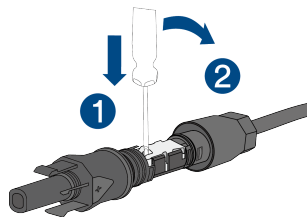

**Step 3:** Push the sealing nut up to the thread and tighten. (SW15, Torque: 2.0 Nm)

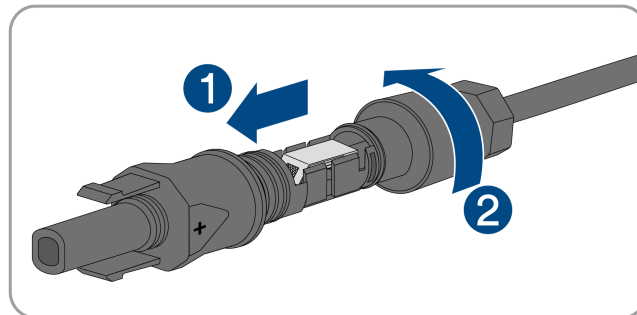

### 6.5.3 Connecting the PV module

#### **DANGER**

**Danger to life due to high voltages in the inverter!**

When exposed to light, the PV modules generate high DC voltage which is present in the DC cables. Touching live DC cables results in death or lethal injuries due to electric shock.

- Before connecting the PV array, ensure that the DC switch is switched off and that it cannot be reactivated.
- Do not disconnect the DC connectors under load.

#### **NOTICE**

**The inverter can be damaged by overvoltage!**

If the voltage of the strings exceeds the maximum DC input voltage of the inverter, it may become damaged due to overvoltage. All warranty claims become void.

- Do not connect strings with an open-circuit voltage greater than the maximum DC input voltage of the inverter.
- Check the design of the PV system.

**Procedure:**

**Step 1:** Ensure that the DC switch is switched off and ensure that it cannot be inadvertently switched on.

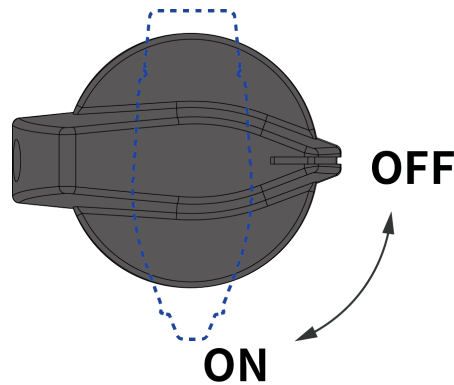

**Step 2:** Ensure that there is no ground fault in the PV array.

**Step 3:** Check whether the DC connectors have been installed with the correct polarities.

If the DC connector connected to a DC cable with the wrong polarity, the DC connector must be reassembled and connected to a DC cable with the correct polarity. The DC cable must always have the same polarity as the DC connector.

**Step 4:** Ensure that the open-circuit voltage of the PV array does not exceed the maximum DC input voltage of the inverter.

**Step 5:** Connect the assembled DC connectors to the inverter until they audibly click into place.

**NOTICE**

Do not use DC switch during the operation of the inverter, otherwise it will cause the inverter to stop or even damage the inverter.

- Connect the assembled DC connectors to the inverter.

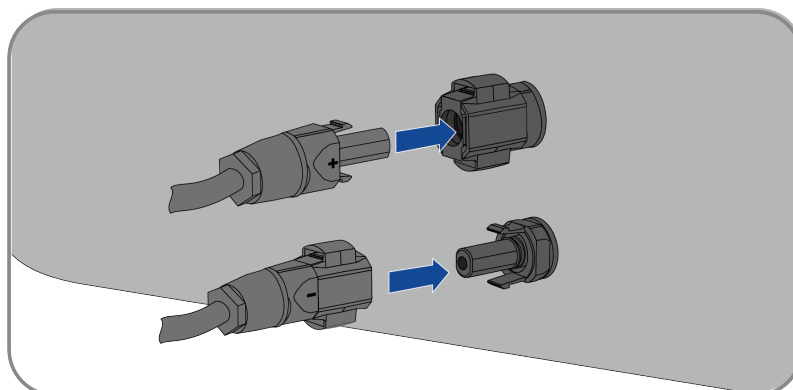

- For unused DC connectors, push down the wire clamp and push the sealing nut up to the thread. Insert the unused DC connectors with sealing plugs into the corresponding DC inputs on the inverter.

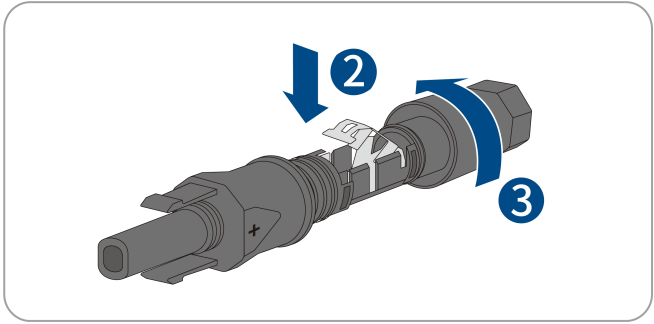
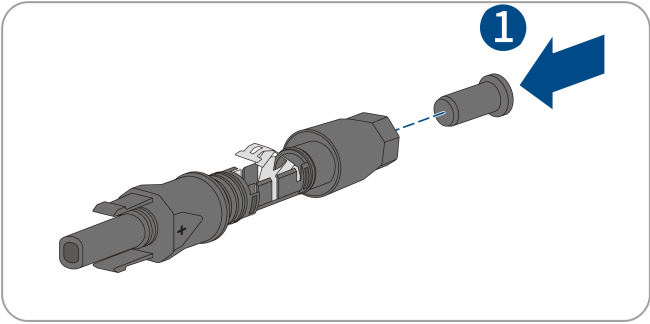

- Insert the DC connectors with sealing plugs into the corresponding DC inputs on the inverter.

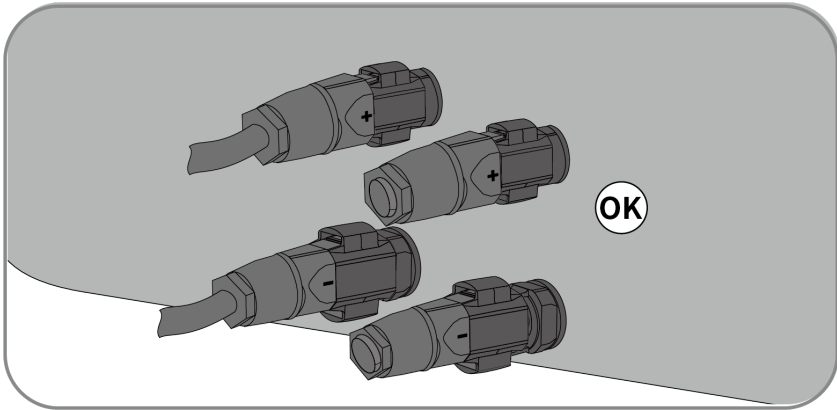

## 6.6 Battery connection

### 6.6.1 Requirements for the Battery connection

Assemble the Battery connectors as described in the following section.

Before connecting the battery, it is important to make sure that the battery is officially listed in the hybrid-battery compatibility list, please download the list from the website: <https://solplanet.net>.

Assemble the battery connectors as described below. Be sure to observe the correct polarity. The Battery connectors are marked with the symbols “+” and “-”.

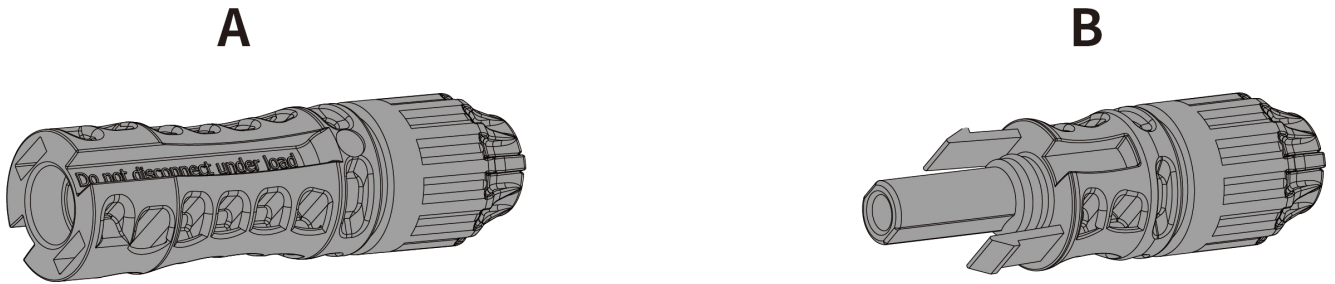

#### Cable requirements:

Item	Description	Value
1	External diameter	6.4-8.5 mm
2	Conductor cross-section	10 mm <sup>2</sup> / 8AWG
3	N Number of copper strands	At least 7
4	The rated voltage	≥1100v

### 6.6.2 Assembling the Battery Connectors

#### Procedure:

**Step 1:** Strip 6-7.5 mm of the cable insulation from the cable.

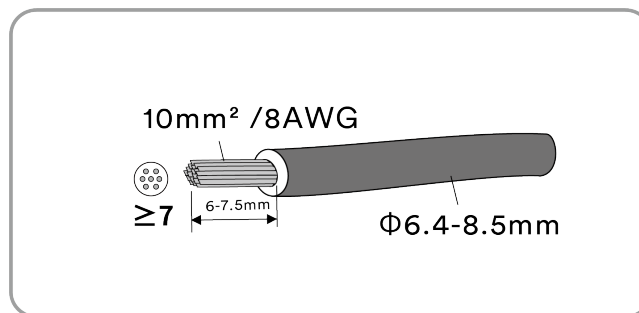

**Step 2:** Assemble the cable ends with the appropriate crimping tools.

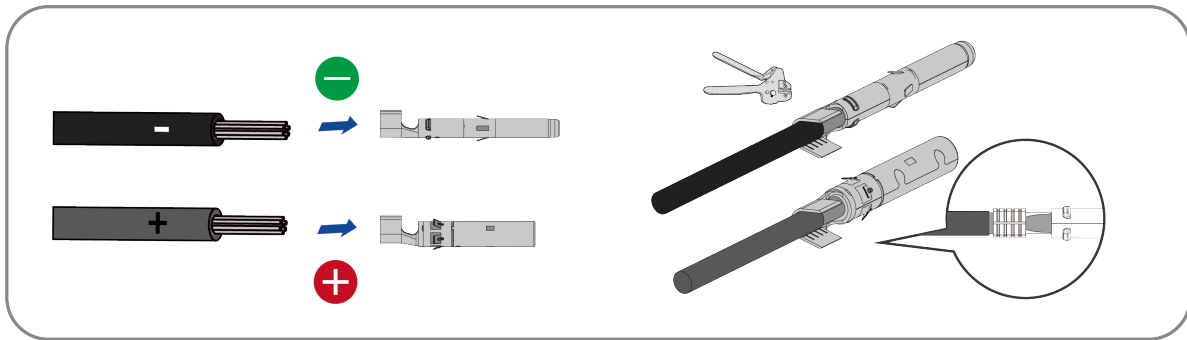

**Step 3:** Insert the cable through cable gland, and insert into the housing until it snaps into place. Gently pull the cable backwards to ensure firm connection. Tighten the cable gland and the housing (Torque 4Nm).

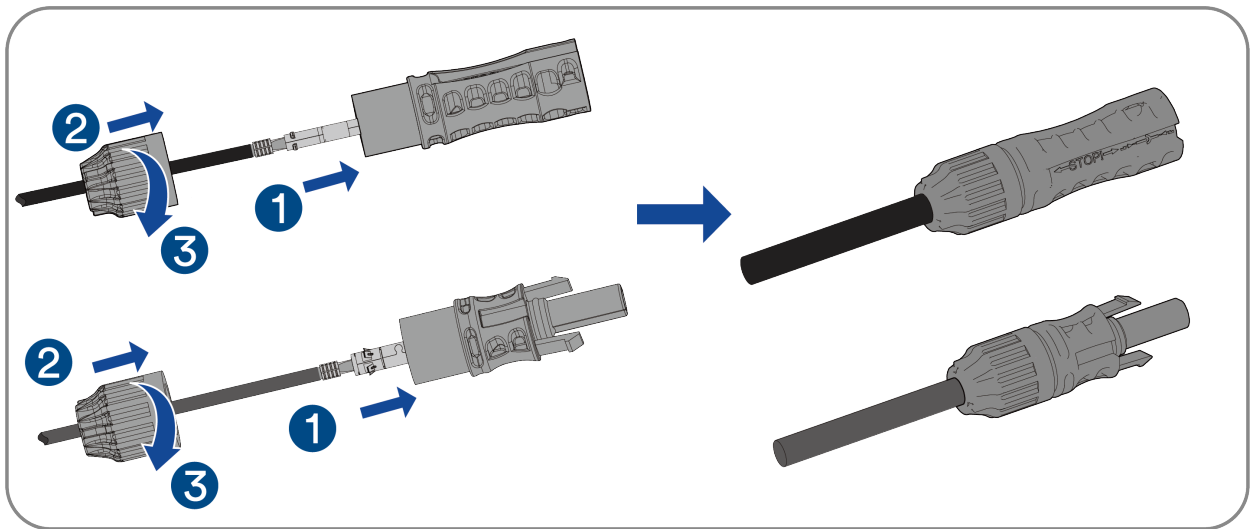

**Step 4:** Ensure that the cable is correctly positioned.

### 6.6.3 Connecting the battery connectors

**Step 1:** Remove the dust and waterproof cover of the battery connector on the inverter.

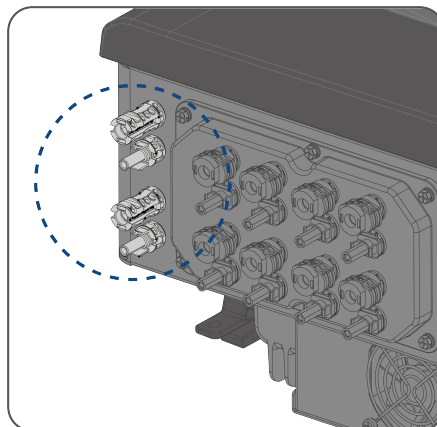

**Step 2:** Connect the assembled battery connectors to the inverter.

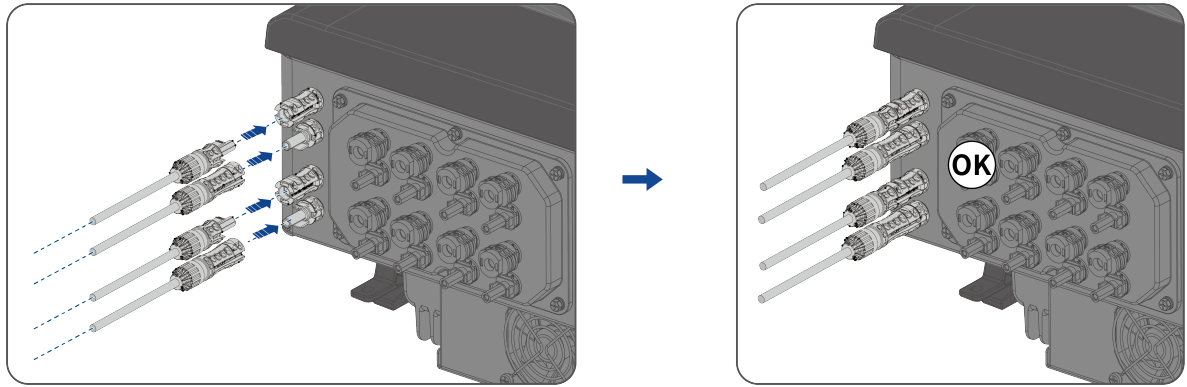

**Complete the installation.**

## 6.7 Ai-Dongle connection with LAN cable

### Procedure:

**Step 1:** Rotate the sealing nut, remove the sealing ring, Press the clips on both sides of the Ai-dongle to open the casing (Note:try not to touch the PCBA component).

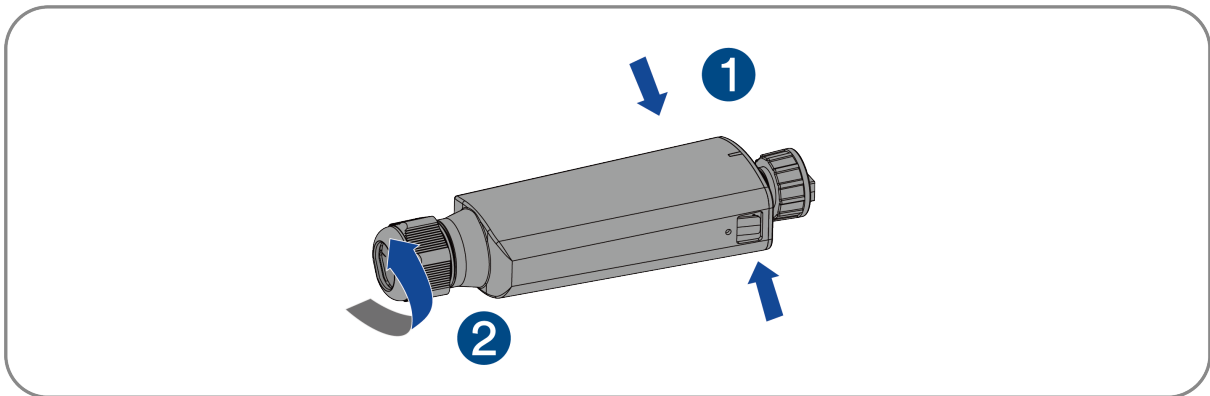

**Step 2:** Connect the communication cable to the wiring terminal according to the sequence shown in the following figure.

**Step 3:** Insert the wiring terminal into the Ai-Dongle body, adjust the communication cable, insert the sealing ring, and lock nut.

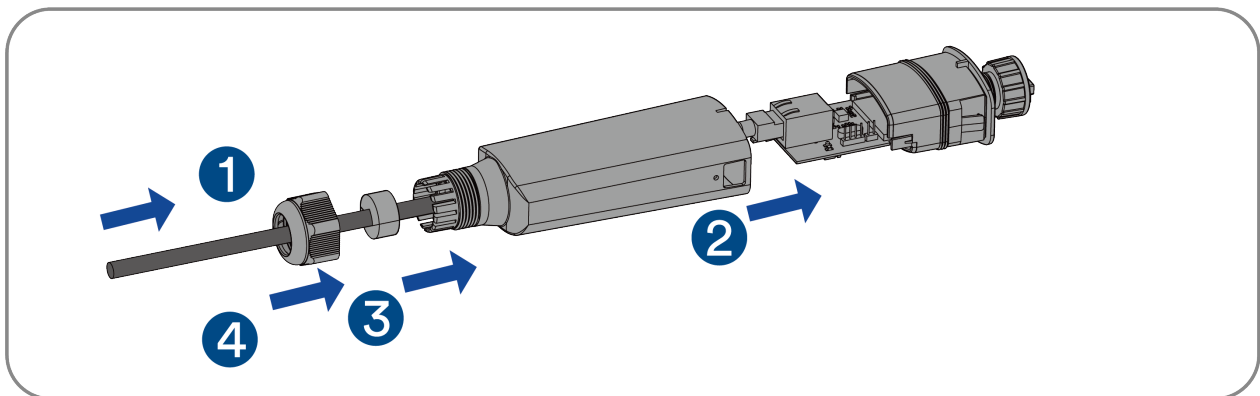

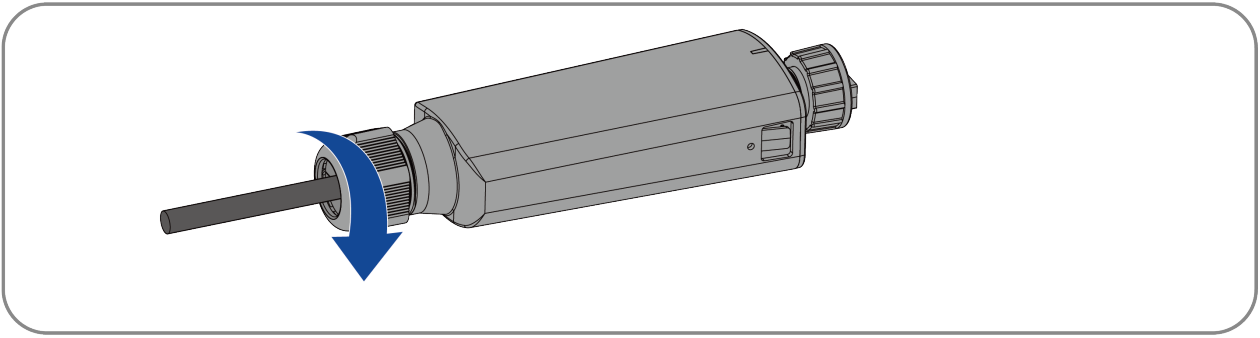

**Step 4:** Remove the cover of the Ai-Dongle port on the inverter and retain it .

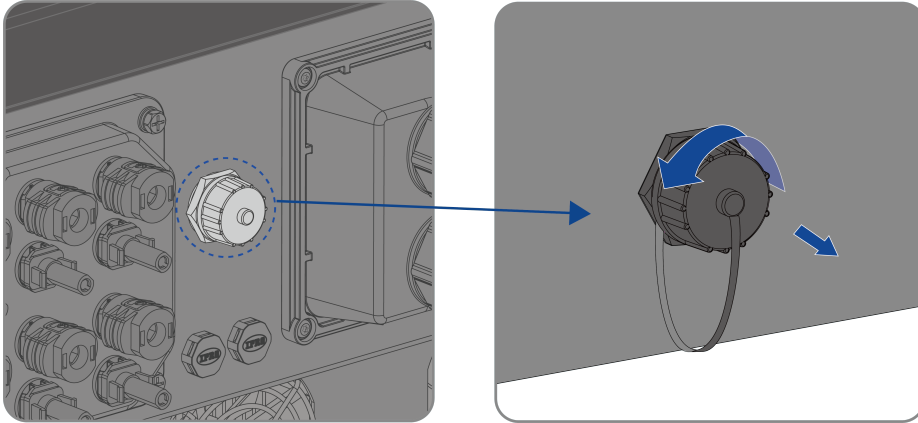

**Step 5:** Connect the Ai-Dongle to the Ai-Dongle port and secure it by tightening the locking nut. Ensure the Ai-Dongle is securely connected with the label clearly visible.

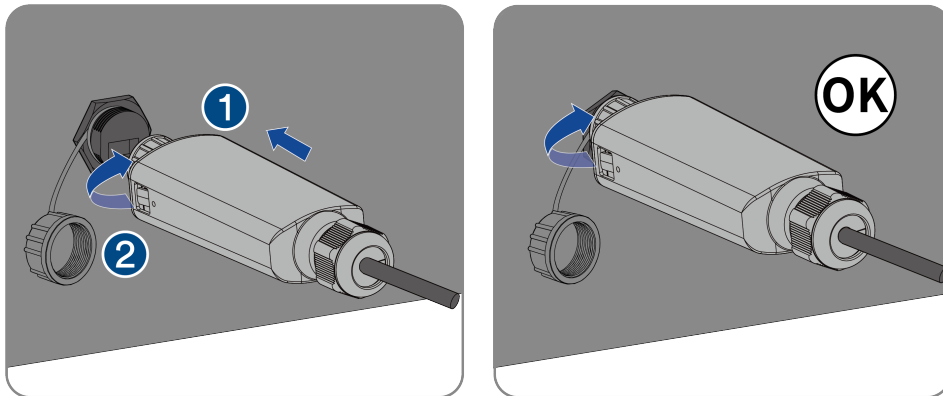

**Complete the installation.**

## NOTICE

**Rotating the body of the Ai-dongle will damage it!**

The Ai-dongle body is protected by a locking nut to protect the ensure a secure connection. If it is rotated, the Ai-dongle may become damaged.

- It can only be locked with the supplied nut.
- Do not rotate the body of the Ai-dongle.

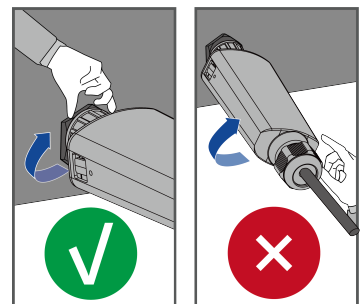

## 6.8 Communication Equipment Connection

### 6.8.1 Communication Interface Description

The inverter features a communication board with multiple interfaces, supporting connections like the lithium battery BMS, smart meter, Ripple control receiver, and EPS parallel (reserved). The interface layout is shown below

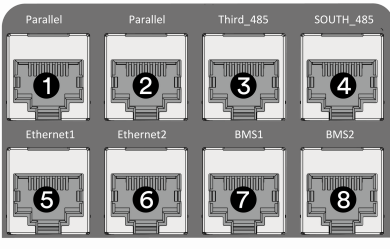

No.	PCB.No.	Description	Terminal	PIN definition							
				1	2	3	4	5	6	7	8
1/2	CN409/CN410	Parallel(Reserved)	COM1/2	RS485A _PARA	RS485B _PARA	X	RS485A _SYNC	RS485B _SYNC	X	CANBH _PARA	CANBL _PARA
3	CN407	Third_485	COM3	RS485A	RS485B	GND	X	X	X	X	X
4	CN418	SOUTH_485 (Reserved)	COM4	RS485A	RS485B	GND	X	X	X	X	X
5/6	CN421/CN422	Ethernet	COM5/6	TX+	TX-	RX+	X	X	RX-	X	GND
7	CN402	BMS1	COM7	X	GND	X	CANH	CANL	X	X	X
8	CN417	BMS2	COM8	X	GND	X	CANH	CANL	X	X	X

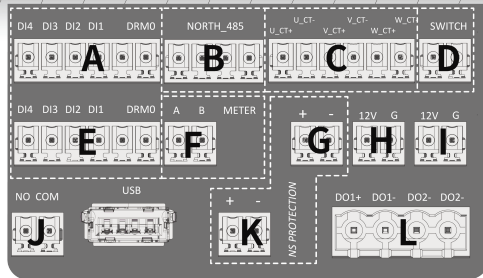
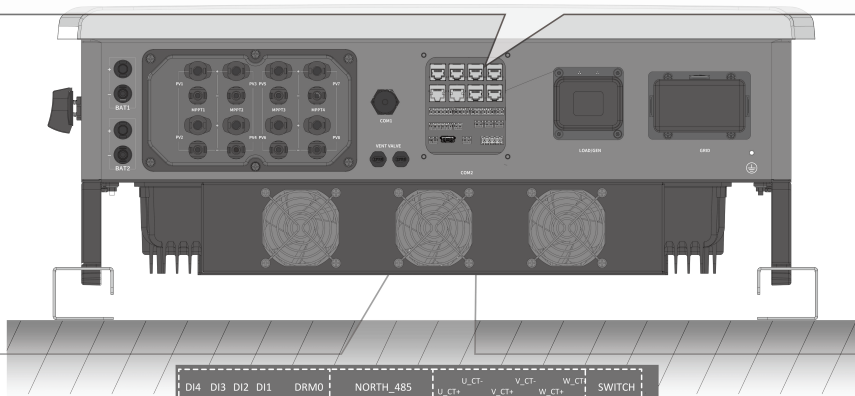

No.	PCB.No.	Description	Terminal	PIN definition					
				1	2	3	4	5	6
A/E	CN405/CN408	DI*4/DRM0	6pin	Ripple Control Receiver Device				DRMS Device	
				DI_4	DI_3	DI_2	DI_1	REF GEN/0	Com LOAD/0or GND
B	CN414	North_485 (Reserved)	4pin	RS485A	RS485B	GND	\	\	
C	CN406	CT (Reserved)	6pin	Current Transformer L1		Current Transformer L2		Current Transformer L3	
				Red	Black	Red	Black	Red	Black
D	CN411	ON/OFF	2pin	DI	GND	\	\	\	
F	CN413	Meter	2pin	RS485A	RS485B	\	\	\	
G/K	CN416/CN412	NS protection	2pin	NS-Protection (network and system protection) Device		\	\	\	
				Positive	Negative	\	\	\	
H/I	CN404/CN415	External output_12V	2pin	Selv_12V	GND	\	\	\	
J	CN420	AI-HUB_DI (Reserved)	2pin	DI	GND	\	\	\	
L	CN401	DO1/DO2	4pin	Multifunctional Relay				\	
				DO1		DO2		\	
				A	B	A	B	\	

Com port	Description	Function
USB	USB port(Reserved)	The firmware can be stored in a USB stick. The product will update automatically after inserting a USB stick into the USB interface.
RJ45-1/2	Parallel port (Reserved)	Reserved for EPS parallel function.
RJ45-3	Third_485 port	This RS485 interface is used to connect the product to a third-party monitoring device.
RJ45-4	SOUTH_485 port (Reserved)	Reserved for devices with 485 communications.
RJ45-5/6	Ethernet port	The product is equipped with two ethernet interfaces. The ETH interface is used to support TCP/IP communication protocol, which can be connected to router. It also can be connected to the AI-HUB for Grid parallel function.
RJ45-7/8	BMS communication port	This CAN interface is used to connect the BMS of the battery. The RJ45-7 is used to connect the BMS of the battery that is connected to the BAT1 port, the RJ45-8 is used to connect the BMS of the battery that is connected to the BAT2 port.
Terminal-A/E	DRMs device /Ripple control receiver device	Terminal block A/E can be used to connect the DRMs device and a ripple control receiver. The PIN definition is shown as in the above table. Note that PIN 6 (GND) is a common for both devices. The Ripple control receiver device can be connected to (pin1~pin4, pin6), the DRMO device can be connected to (pin5, pin6).Choose either one of the two interfaces.
Terminal-B	North_485 interface(Reserved)	This RS485 interface is reserved.
Terminal-C	Current transformer interface (Reserved)	Terminal block C can be used to connect three current transformers (CT's). CT's can be used to measure the active power at the grid connection point. The PIN definition is shown in the table above. These CT's are optional and should be used if the smart meter is not installed.
Terminal-D	ON/OFF Device	Terminal block D is used as a dry contact to startup/shutdown the inverter.
Terminal-F	Smart Meter	Terminal block F can be used to connect the smart meter.
Terminal-G/K	NS-protection (network and system protection) Device	The product is equipped with one communication interface to connect an external central grid protection device. Choose either one of the two interfaces.
Terminal-H/I	External output	This product is equipped with external output function. This function can be connected to terminal block H/I. When the inverter is in "ON" status, it will provide 12 Vdc.
Terminal-J	AI-HUB_DI(Reserved)	The terminal block J is a DI signal interface sent from the AI-HUB to the inverter.
Terminal-L	Multifunction Relay	The product is equipped with two multifunction relays as standard. One of the relays can serve as a dry contact signal for controlling a diesel generator. When the diesel generator function in the Solplanet App is enabled and the diesel generator connection conditions are met, the open contact will switch to on (voltage free output).

## 6.8.2 Communication cable connection

The communication interface has provisions for three different types of connectors shown in Step 2:

**Type 1:** Push in connector

**Type 2:** RJ45 connector

**Type 3:** Plug-in screw connector

**Step 1:** Remove the communication cover.

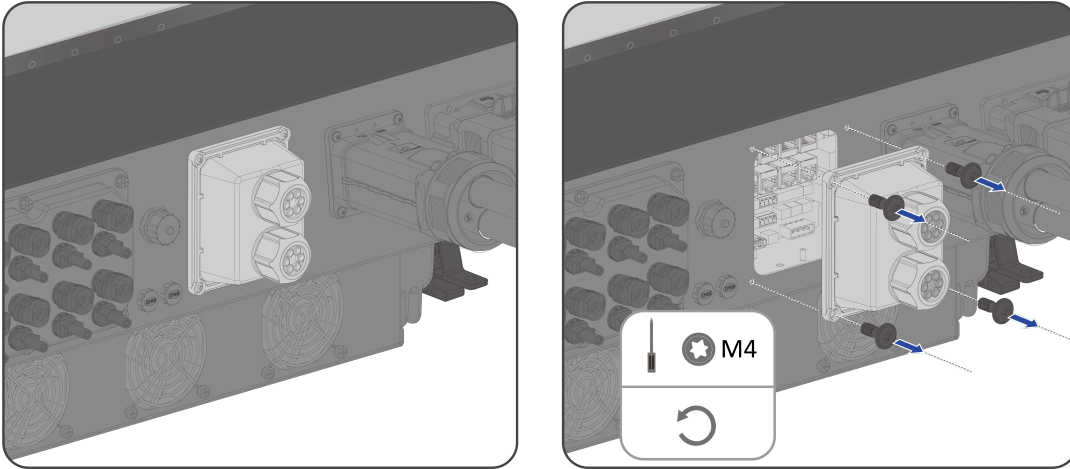

**Step 2:** Insert the required communication cable(s) through the communication cover and ensure the correct connector is used and secured onto the cable(s).

The wiring terminal crimping sequence is illustrated below:

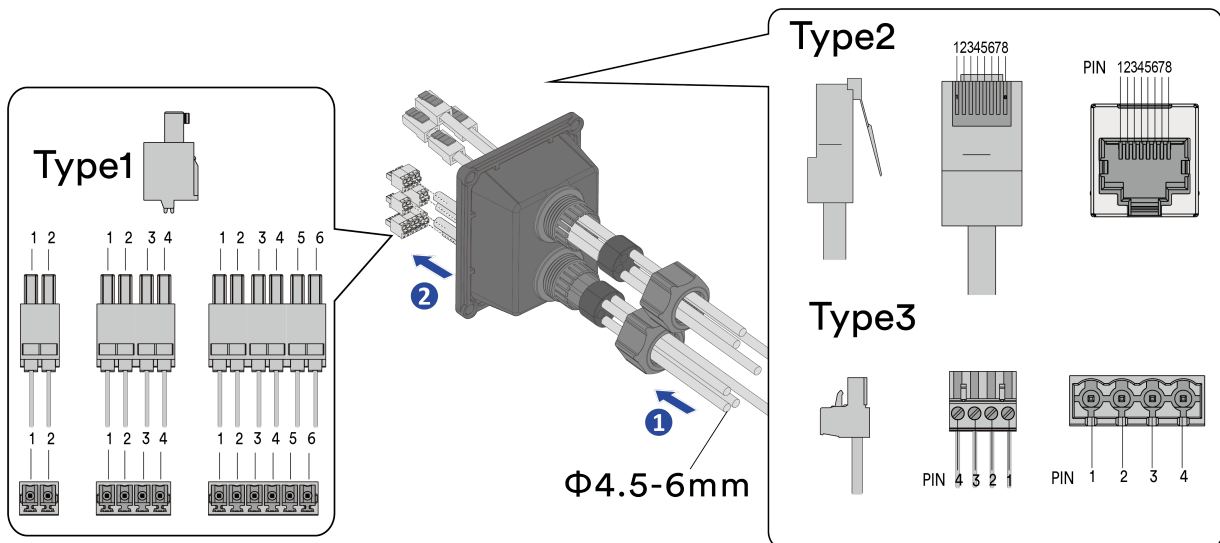

**Step 3:** Connect the communication cable to the corresponding communication port.

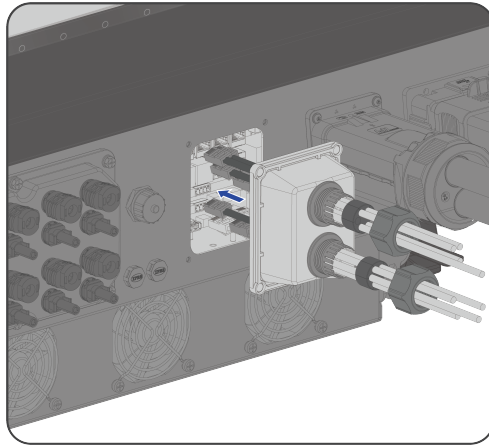

**Step 4:** Install the communication cover on the inverter.

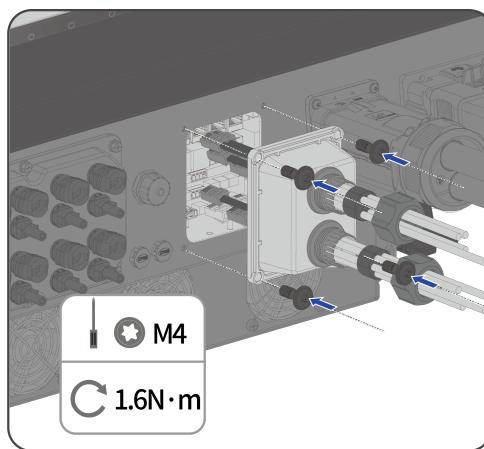

**Step 5:** Tighten the cable gland nuts.

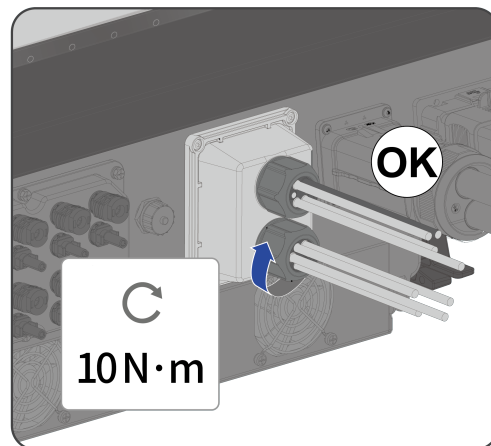
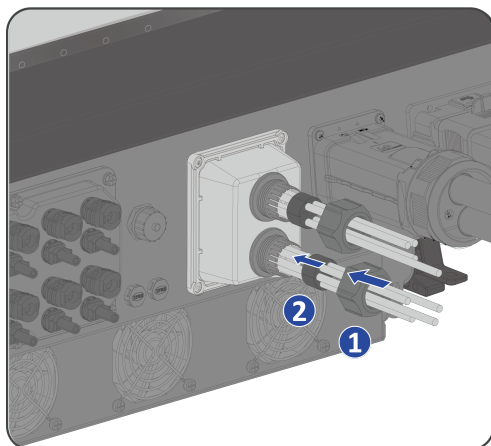

**Complete the installation.**

### 6.8.3 Ripple control receiver connection

The product is equipped with two interfaces (terminal block A/E) to connect a Ripple Control Receiver device. Choose either one of the two interfaces. The Ripple control receiver device can be connected to terminal block A/E (pin1-pin4, pin6).

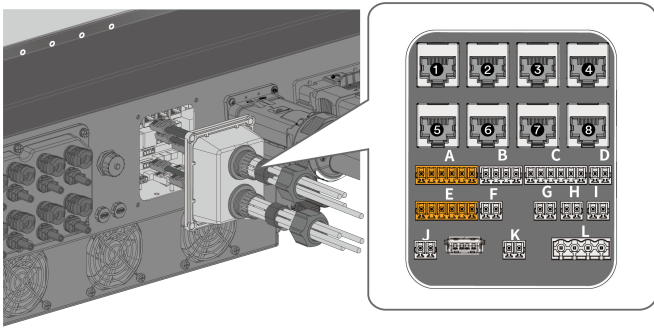

Position	PIN	Assignment
A/E	1	DI_4
	2	DI_3
	3	DI_2
	4	DI_1
	5	REF GEN/0
	6	COM LOAD/0or GND

**Step 1:** Remove the cable jacket and strip the wire insulation.

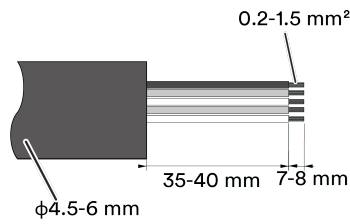

**Step 2:** Remove the push-in connector from the accessory pack. Insert the stripped wires into the push-in terminal connector.

**Step 3:** Insert the push-in connector into the connection panel and ensure the connection is secure.

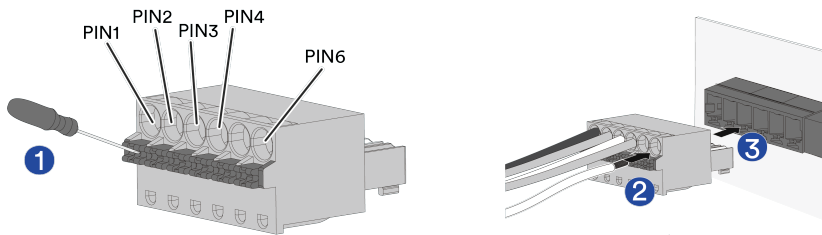

**Step 4:** Strip the insulation of the other end of the cable and terminate the wire into the terminal of the ripple control receiver according to the ripple control receiver requirements. Refer to the user manual of the ripple control receiver for further information.

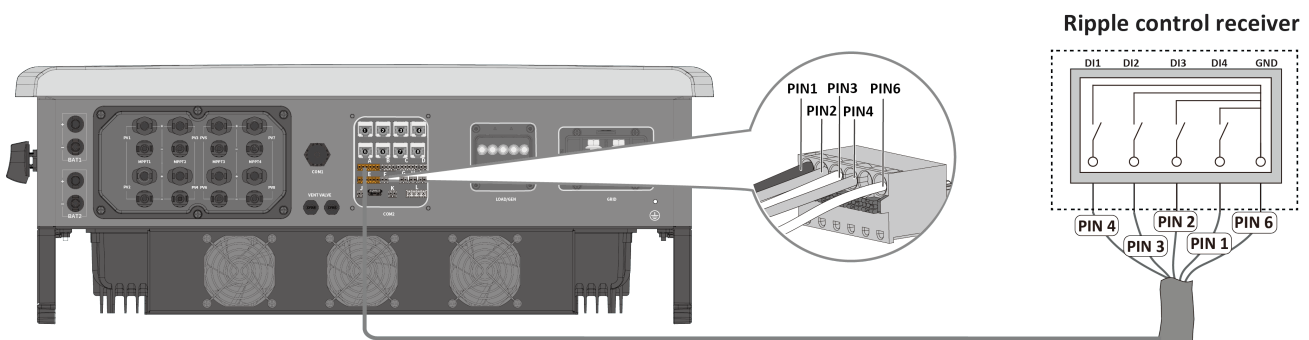

**Installation completed.**



When multiple inverters need to be controlled by RCR (inverters are not connected in parallel by AI-HUB), they can be connected by Daisy chain through the A/E interface of the inverter communication board for unified control (as shown below).

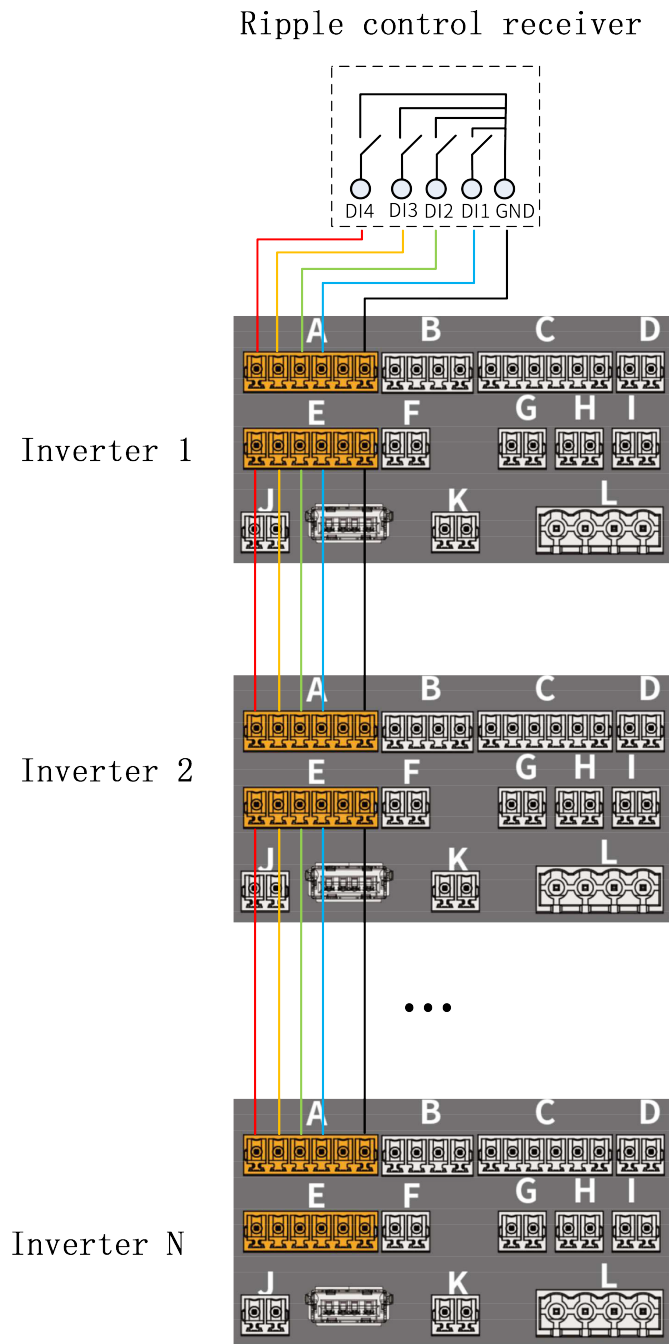

When the collector is a Dongle, the dry contacts are preconfigured in the following way: DI\_4 = 0%, DI\_3 = 30%, DI\_2 = 60%, DI\_1 = 100%, and these default values can also be modified through the APP.

### 6.8.4 NS protection connection

The product is equipped with two connections (terminal block G/K) for connection to an external central grid protection device. Choose either one of the two interfaces.

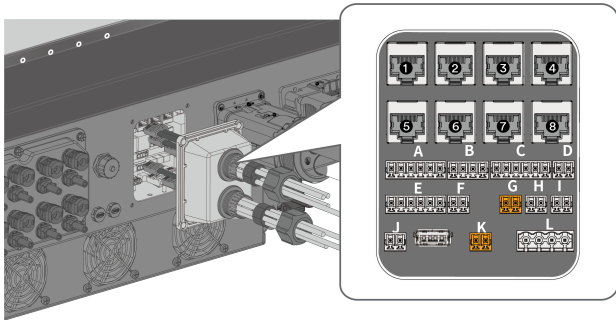

Position	PIN	Assignment
G/K	1	Positive (+)
	2	Negative (-)

**Step 1:** Remove the cable jacket and strip the wire insulation.

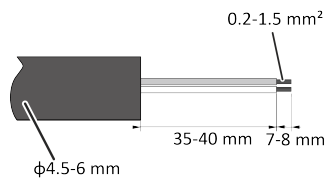

**Step 2:** Remove the push-in connector from the accessory pack. Insert the stripped wires into the push-in terminal terminals.

**Step 3:** Insert the push-in connector into the connection panel and ensure the connection is secure.

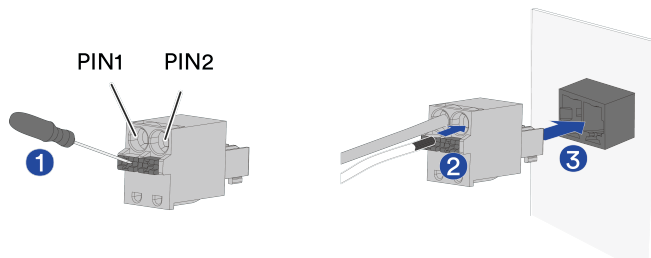

**Step 4:** Strip the insulation of the other end of the cable and terminate the wire into the terminal according to external protection device requirements. Refer to the user manual of the external protection device for further information.

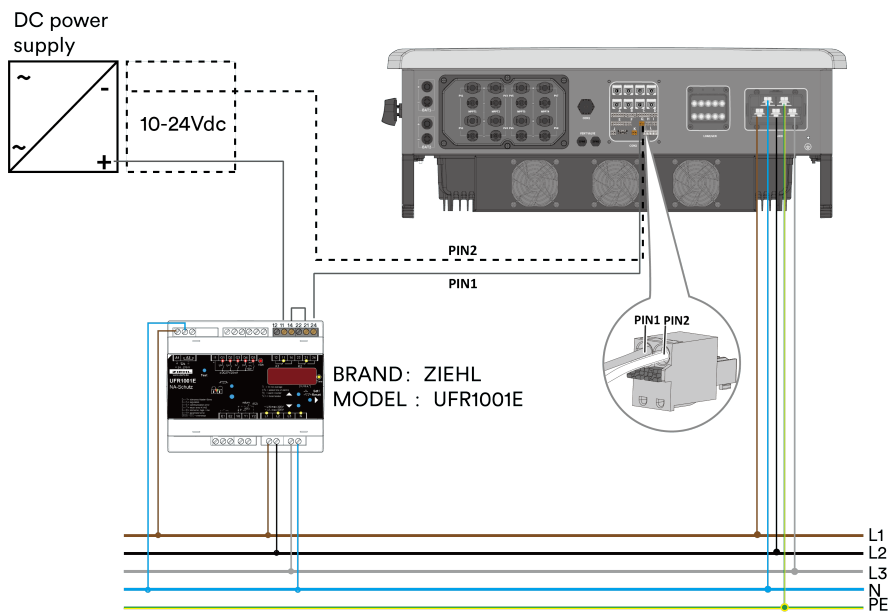

Installation completed.



The Figure above is as reference and the manual of the third party device should be consulted, as also the manuals of other brands.

### 6.8.5 Smart meter connection

The meter in the delivery package is CHINT DTSU666 100A/40mA. The system supports the following meters. The smart meter should be connected in accordance with the smart meter User Manual. Recommend purchasing smart meter from Soplanet, some functions will be limited if purchased from other sources.

Manufacturer	Model	Max current	CTs
CHINT	DTSU666 3*220/380V 100A/40mA 115200bps	100A	3*CT NCTK-16 100A/40mA
CHINT	DTSU666 3*220/380V 10(100)A 115200bps	100A	NA
CHINT	DTSU666 3*220/380V 250A/50mA 115200bps	250A	3*CT NCTK-24 250A/50mA
CHINT	2.5P DTSU666 3*220/380V 400A/40mA 115200bps	400A	3*CT NCTK-36 400A/40mA

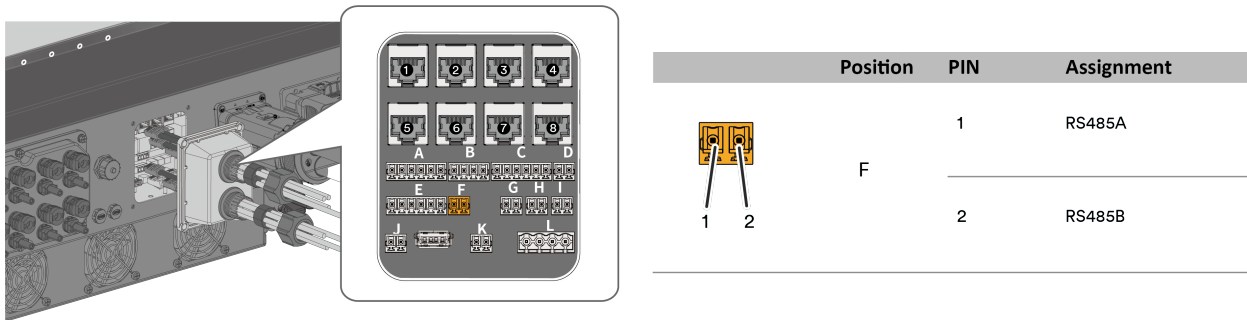

**Step 1:** Remove the cable jacket and strip the wire insulation.

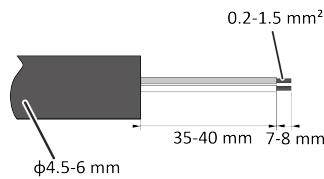

**Step 2:** Remove the push-in connector from the accessory pack. Insert the stripped wires into the push-in terminals.

**Step 3:** Insert the push-in connector into the connection panel and ensure the connection is secure.

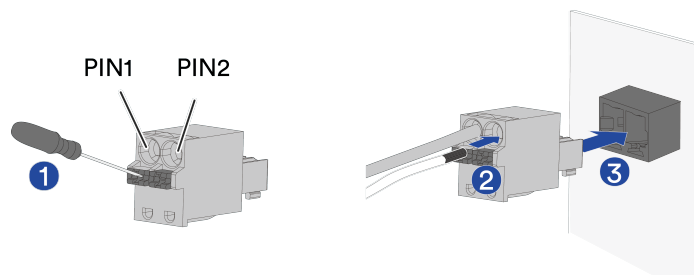

**Step 4:** Strip the insulation of the other end of the cable and terminate the wire into the terminal according to the smart meter requirements.

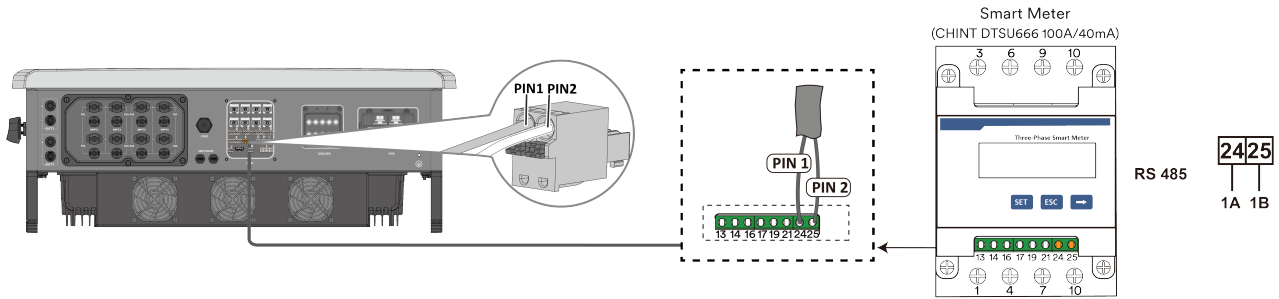

The specific smart meter (CHINT DTSU666 100A/40mA) connections are shown below:

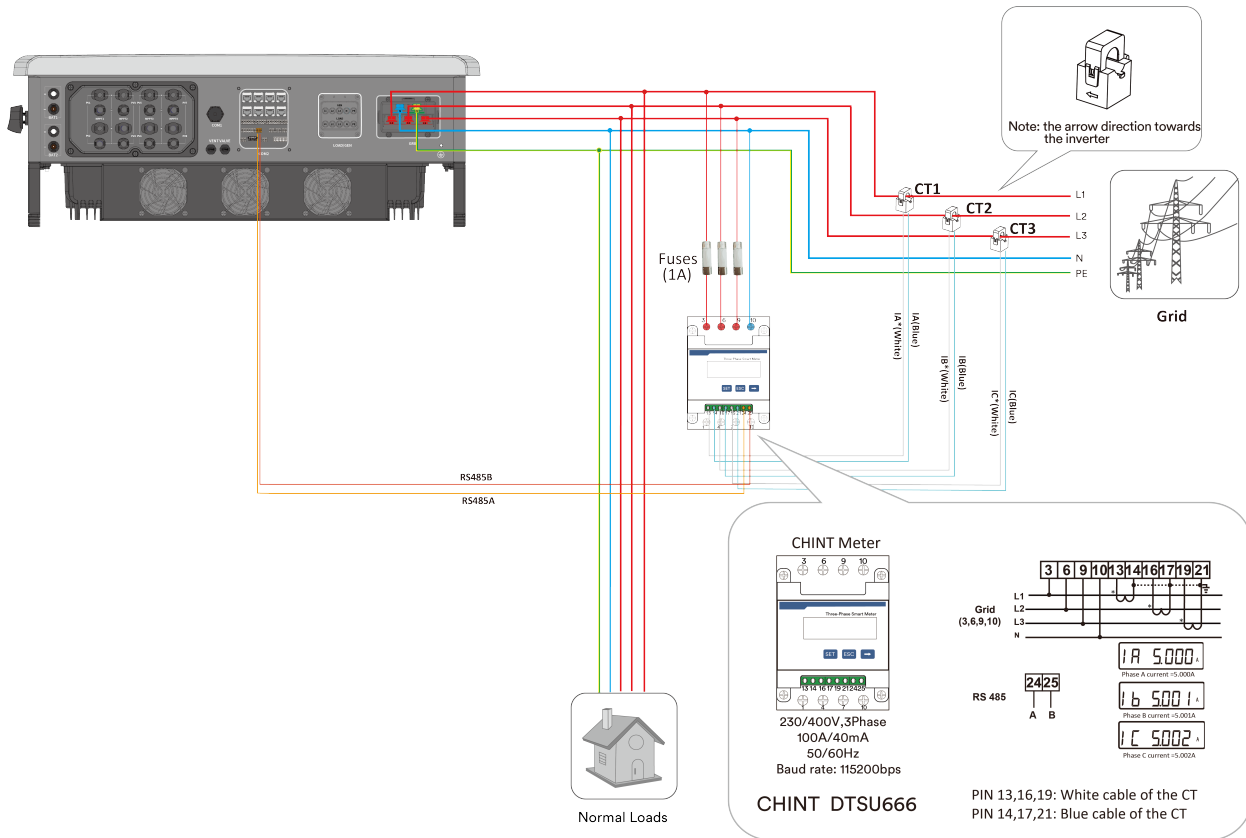

The specific smart meter (CHINT DTSU666 3x230/400V 10(100)A) connections are shown below:

CHINT DTSU666 3x230/400V 10(100)A is an optional accessory.

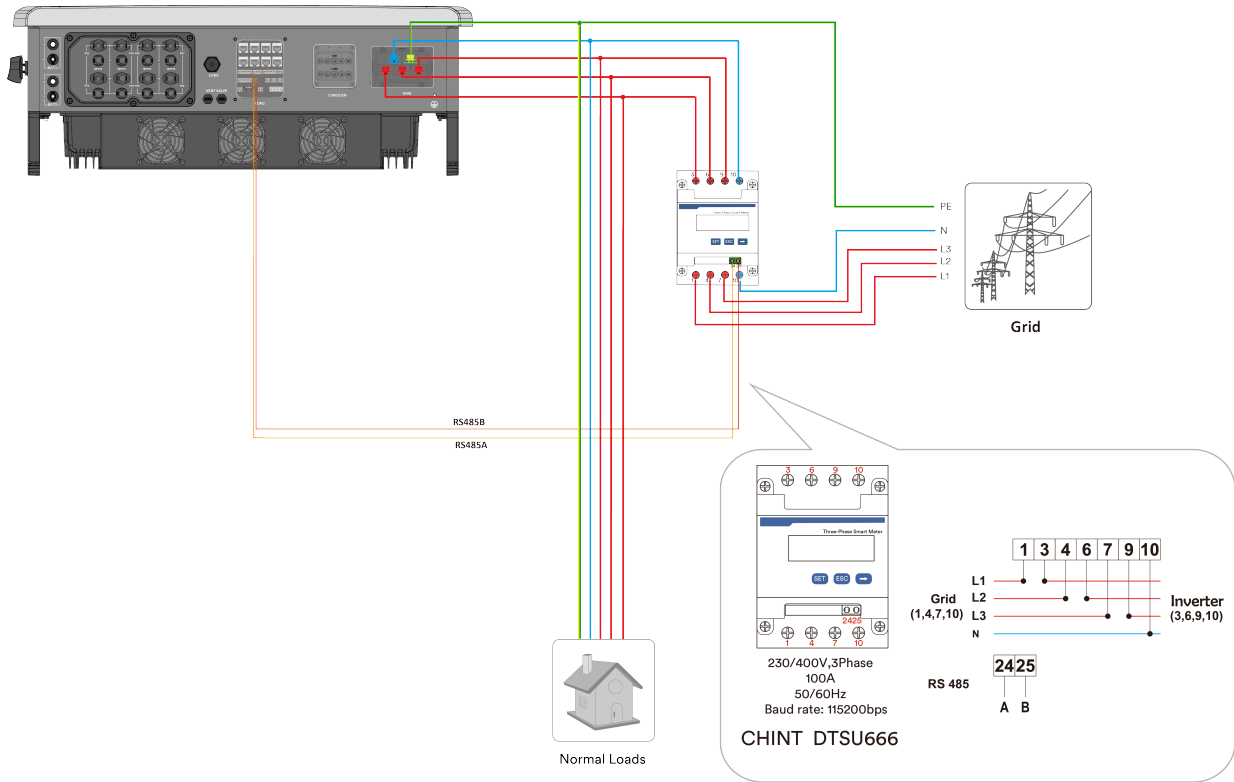

Installation completed.

## 6.8.6 BMS Connection



Ensure that RJ45- ⑦ and RJ45- ⑧ are connected correctly. If they are reversed, communication will not be possible.

- The inverter provides two CAN ports for connecting to the BMS of the battery: RJ45- ⑦ for connecting to the BMS of battery 1 and RJ45- ⑧ for connecting to the BMS of battery 2.
- i.e., for ASW015-020K-TH, only one battery can be connected to RJ45- ⑦ ; for ASW025-030K-TH, RJ45- ⑦ is connected to the BMS of battery 1, RJ45- ⑧ is connected to the BMS of battery 2.

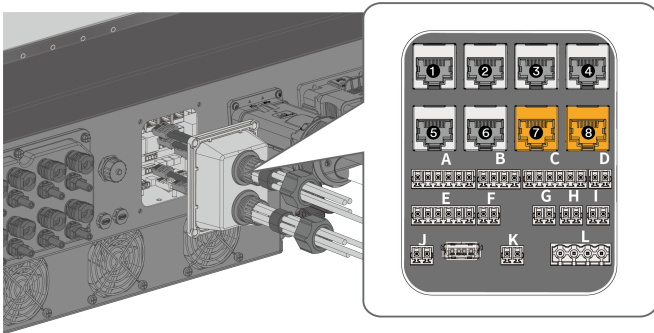

Position	PIN	Assignment
1		/
2		GND
3		/
⑦ (BMS1)	4	CANH
/	5	CANL
⑧ (BMS2)	6	/
7		/
8		/

**Step 1:** Plug the network cable port into the connection panel.

**Step 2:** Plug the other end of the network cable into the battery communication port, refer to the battery user manual.

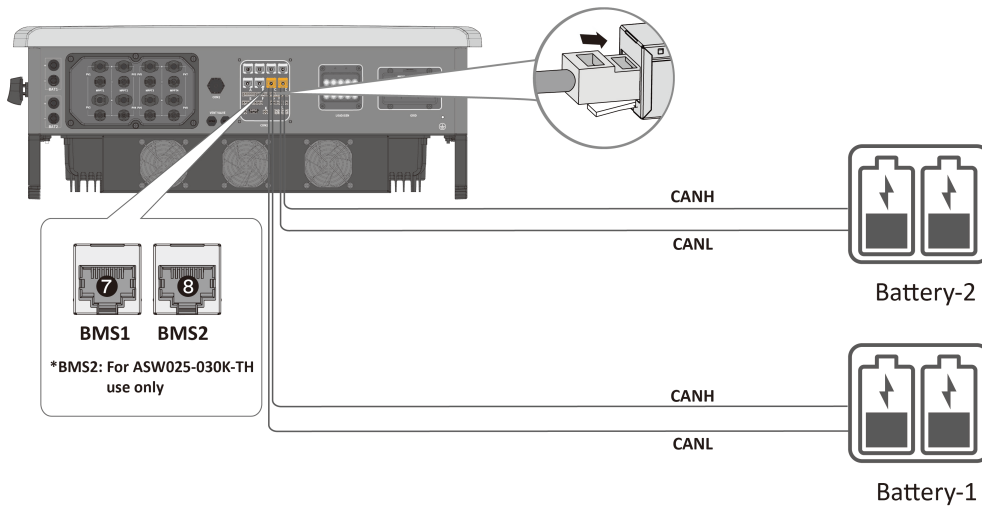

**Complete the installation.**

## 7 Commissioning and operation

### 7.1 Inspection before commissioning

#### CAUTION

##### Danger to life due to high voltages on DC conductors!

When exposed to sunlight, the PV array generates DC voltage which is present in the DC conductors. Touching the DC and AC conductors can lead to lethal electric shocks.

- Only touch the insulation of the DC cables.
- Only touch the insulation of the AC cables.
- Do not touch ungrounded PV modules and brackets.
- Wear personal protective equipment, such as insulating gloves.

Check the following items before starting the inverter:

- Make sure the inverter DC switch and external circuit breaker are turned off.
- Make sure the inverter has been correctly mounted with wall bracket.
- Make sure the top side of the inverter is free of objects.
- Make sure the communication cable and AC connector have been correctly wired and tightened.
- Make sure the inverter's exposed metal surface has a ground connection.
- Make sure the DC voltage of the strings do not exceed the permitted limits of the inverter.
- Make sure the DC voltage has the correct polarity.
- Make sure that the insulation resistance to ground is greater than the allowed local insulation resistance protection value.
- Make sure the grid voltage at the point of connection of the inverter complies with the permitted value of the inverter.
- Make sure the AC circuit breaker complies with this manual and all applicable local standards.

### 7.2 Commissioning procedure

If all of the items mentioned above meet the requirements, proceed as follows to start up the inverter for the first time.

**Step 1:** Turn the DC switch of the inverter to "ON" position and turn on the battery, keep the breakers on EPS (if used) and grid port to "OFF" position.

**Step 2:** Connect to the inverter via the Solplanet APP, For details, please refer to the latest Solplanet app manual.

**Step 3:** Turn the breakers on EPS (if used) and grid port to "ON" position. If the start-up conditions are met, the inverter will operate normally.

**Step 4:** Observe the LED indicator to ensure inverter operates normally, check the inverter and battery parameters in the Solplanet APP.

## 8 Solplanet APP

### 8.1 Download and install

The corresponding, free Solplanet app can be downloaded from the relevant app store and installed on a mobile device (smartphone or tablet) with an Android operating system (version 9.0 or newer) or iOS operating system (version 11.0 or newer).

Alternatively, scan the QR code below to download and install the app, following the on-screen instructions.



Android



iOS



The Solplanet app manual is subject to update without notice. For more product details and latest documents, please visit [www.solplanet.net](http://www.solplanet.net).

### 8.2 Setting parameters

Please refer to the user manual of the Solplanet APP for creating an account, creating a plant, and setting basic parameters of the inverter.

#### 8.2.1 Generator settings

This function is mainly used to set the function of the generator port. When the function of the generator port is enabled, there are two function modes to choose from, one is the generator mode and the other is the smart load mode. Only one of the two can be selected. Customers can choose according to their actual needs, and after confirming the mode, they also need to set the parameters in the mode.

#### Procedure:

**Step 1:** Tap "Function settings" to enter to the next page.

**Step 2:** Tap "Generator settings" to enter to the next page.

**Step 3:** Tap the button next to "Generator Enable" to enable the generator port function, then Tap "Generator settings" to enter to the next page.

**Step 4:** Choose either "Generator access" or "Smart load access" based on the actual application situation, with only one option available, Configure the parameters and tap "Save".

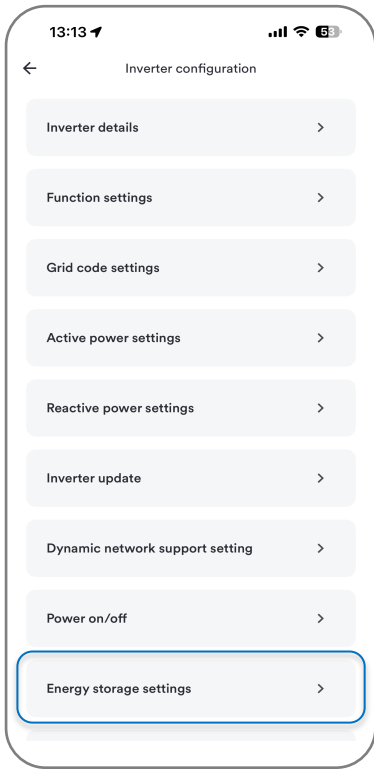

Step 1

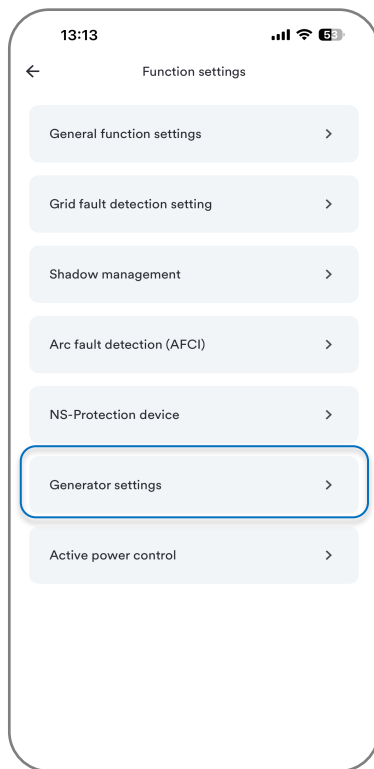

Step 2

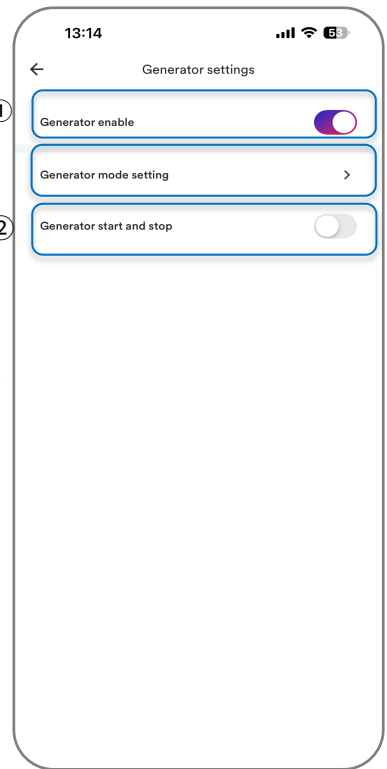

Step 3

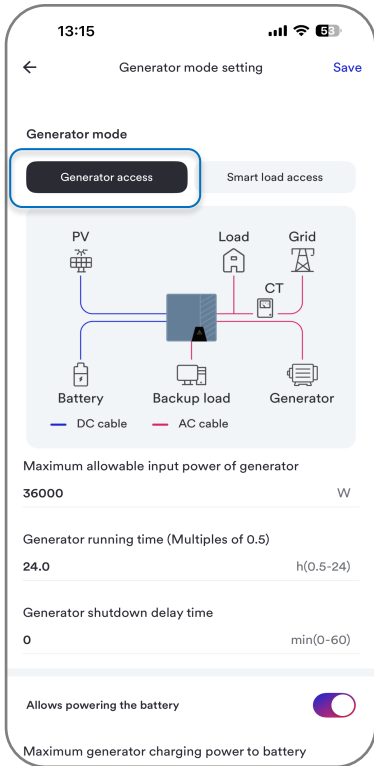

Step 4

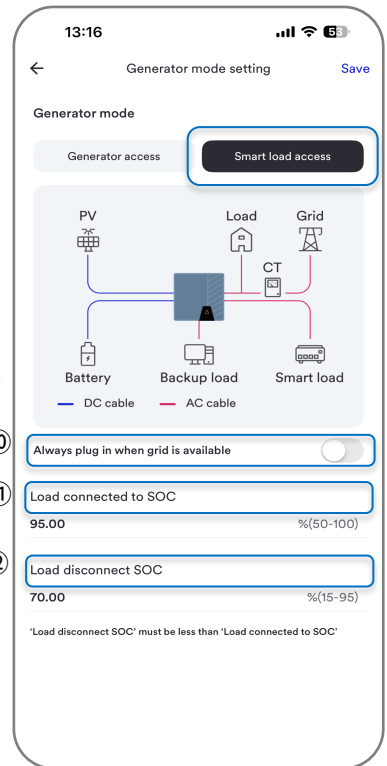
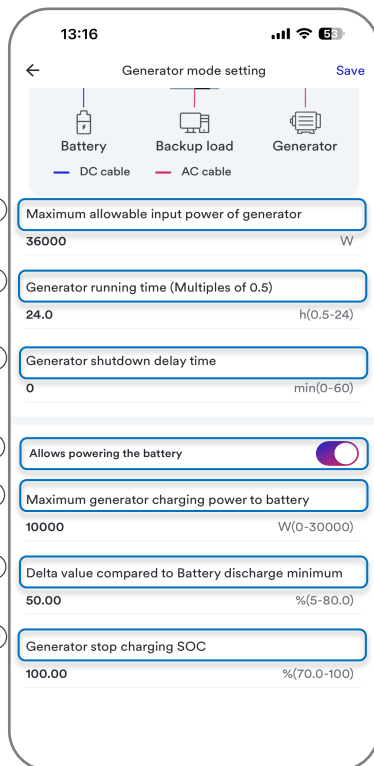

### Table description

No.	Name	Description
○,1	Generator enable	Used to enable the generator port function.
○,2	Generator start and stop	Normally open relay that closes when the Generator Start signal state is active. Remote control of generator start and stop using dry contact signal.
○,3	Maximum allowable input power of generator	allowed Max. power from diesel generator.
○,4	Generator running time	Generator can run in one day, when time is up, the Generator will be turned off.
○,5	Generator shutdown delay time	It indicates the delay time of the Generator to shut down after it has reached the running time.
○,6	Allows powering the battery	uses the generator input of the system to charge battery bank from an attached generator
○,7	Maximum generator charging power to battery	The maximum power allowed for the generator to charge the battery.
○,8	Delta value compared to Battery discharge minimum	When the SOC value of the battery is less than the sum of the set value and the minimum discharge value of the battery, the generator will allow the battery to be charged.
○,9	Generator stop charging SOC	When the SOC value of the battery exceeds the set value, the generator stops charging the battery.
○,10	Always plug in when grid is available	When this function is enabled, the smart load will switch on when the grid is present.
○,11	Load connect SOC	When the SOC value of the battery exceeds the set value, the smart load will be connected
○,12	Load disconnect SOC	When the SOC value of the battery is less than the set value, the smart load will disconnect



The generator access and Smart load access can only be selected as either. Before starting the inverter, it is necessary to confirm whether the selected mode matches the actual working conditions. When the mode is set incorrectly, please change it while shutting down.

When setting the SOC value of battery charging in generator setup page, it should be noted that the actual set value is the increment between the required value and the minimum value of battery discharge.

Generator stop charging SOC is at least 10% greater than the generator start charging SOC.

Load disconnected SOC must be less than load connected to SOC.

The parameter of the maximum generator charging power to battery refers to the maximum power that the generator can output for battery charging, rather than the actual charging power of the battery.

### 8.2.2 Asymmetrical power output

If user enable Asymmetrical power output, the inverter will asynchronous output. Which means that in self-consumption mode with unbalance three phase load, the inverter correspondingly output three-phase imbalance unless load power is too high (above 1/3 rate power) to consume grid power.

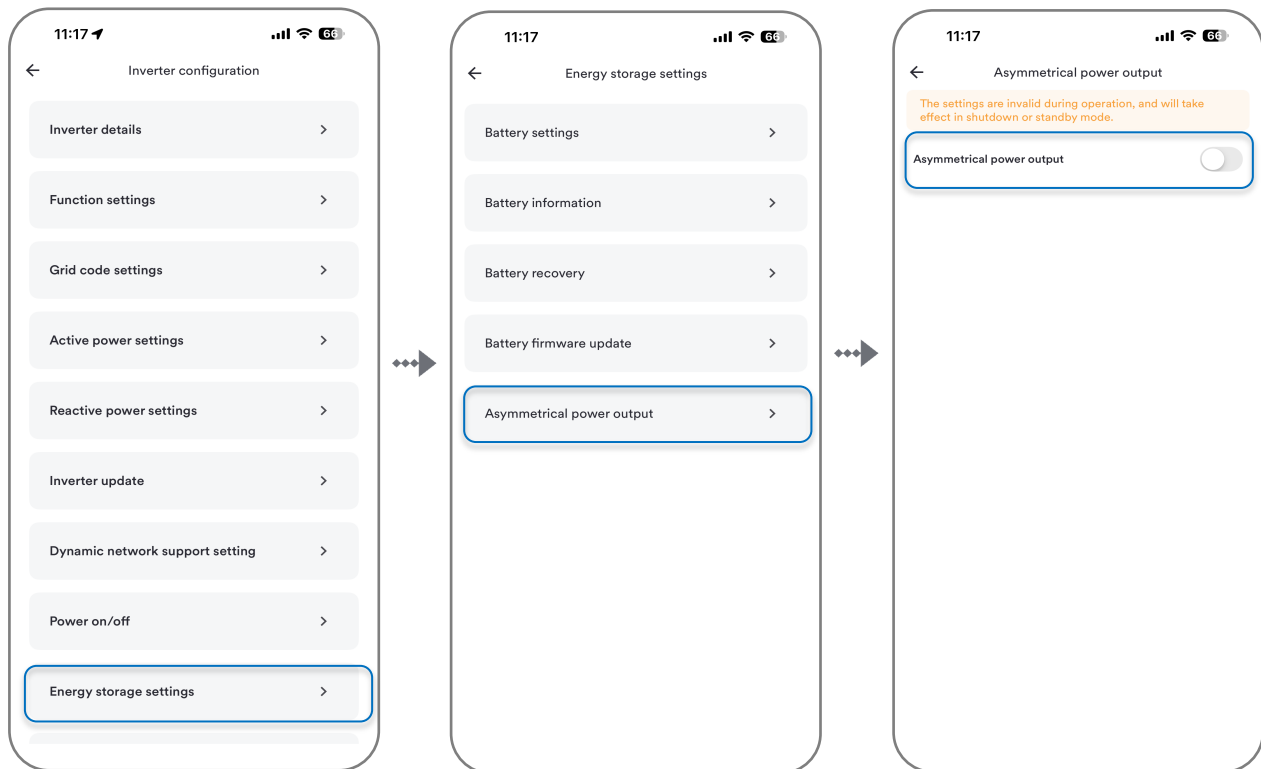

Before enable **Asymmetrical power output**, make sure the phase sequence of CT or meter is consistent with grid and inverter, otherwise inverter will work abnormal.

The settings are invalid during operation, and will take effect in shutdown or standby mode.

### 8.3 Parallel parameter setting and using

This product is connected in parallel with the inverter through the AI-HUB. For example, to create a plant and the use of the AI-HUB function, please refer to the user manual of the AI-HUB and Solplant APP. When using AI-HUB to match this product, such as Drm0, NS\_Protection, RCR and other functions, the terminal should be connected to the AI-HUB, not to the communication board of the inverter.



The firmware of this product currently only supports inverter grid parallel connection.

- When using AI-HUB, when all inverters appear in the interface, tap the "working mode setting" . This function can uniformly set the working mode and battery SOC of all connected hybrid inverters.
- The battery brand and battery module qty need to be clicked into each inverter for setting.
- All inverter Grid code settings can be made with one click through the AI-HUB.
- After modifying the safety parameters of one inverter, you can click to copy the parameters to other inverters of the same type.
- The charging and discharging power set in the custom mode in the working mode is the total battery charging and discharging power of the parallel system.

Working mode settings:

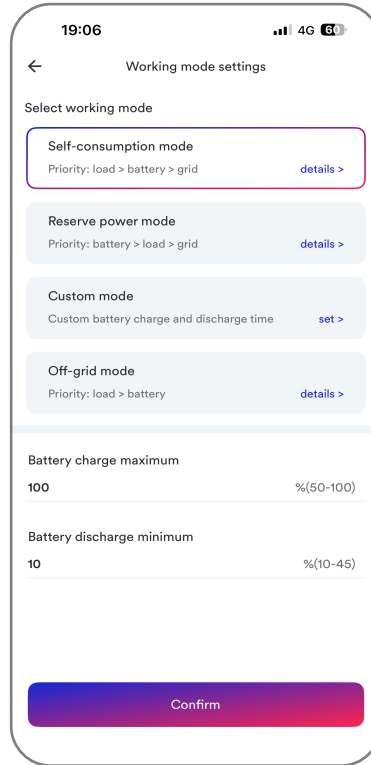
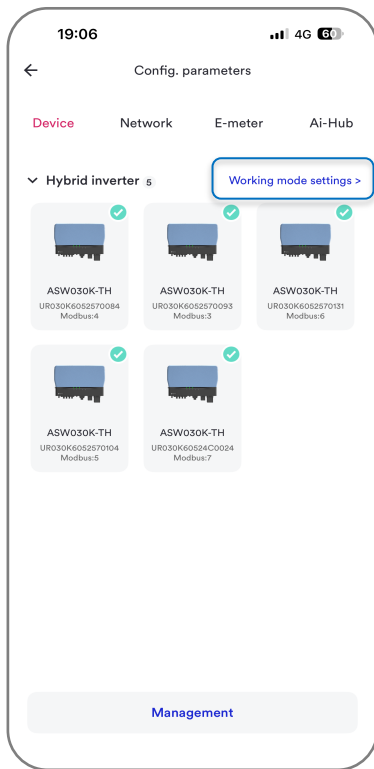

Battery brand and battery module qty settings:

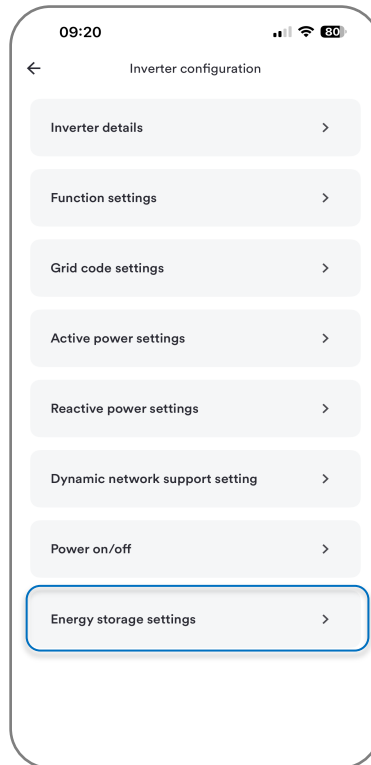
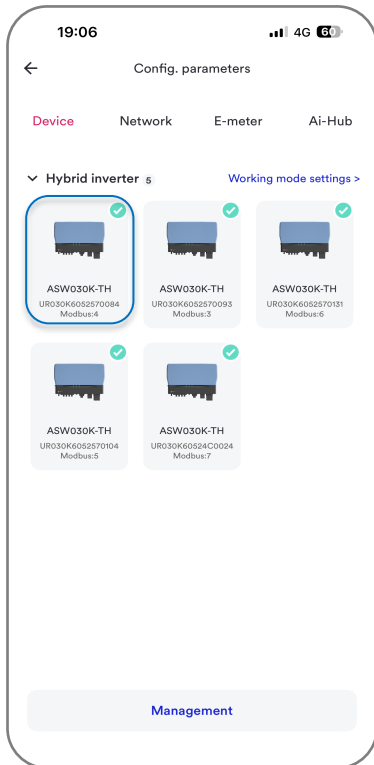

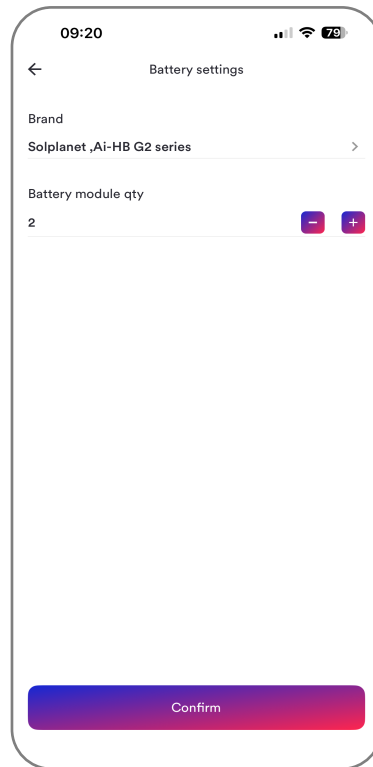
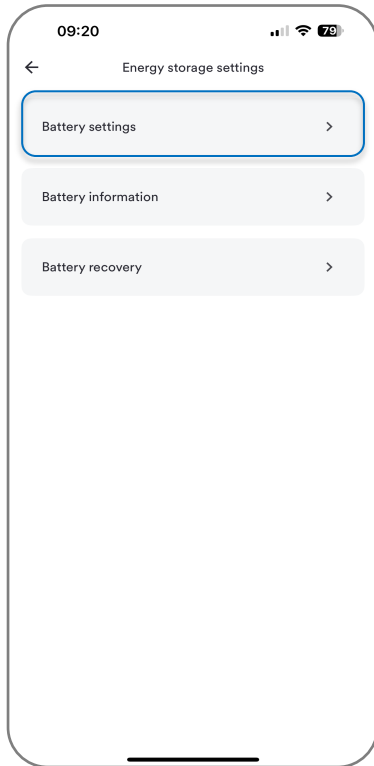

Grid code settings:

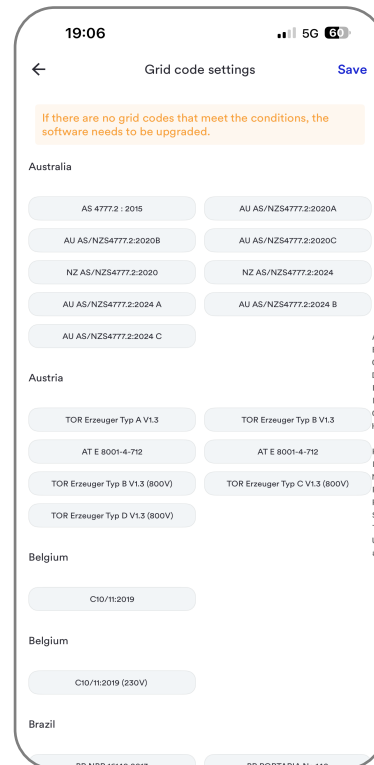
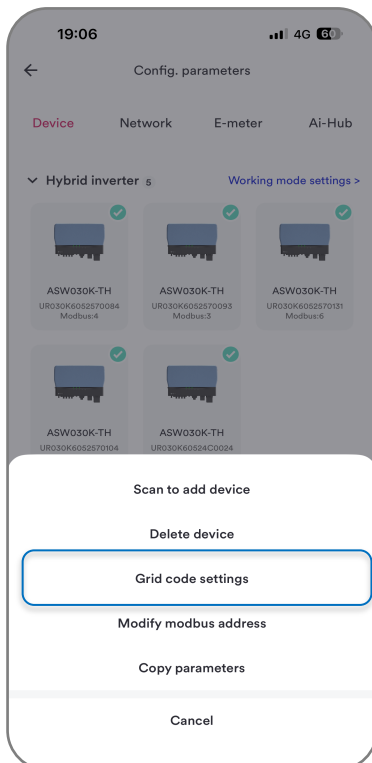

Copy parameters settings:

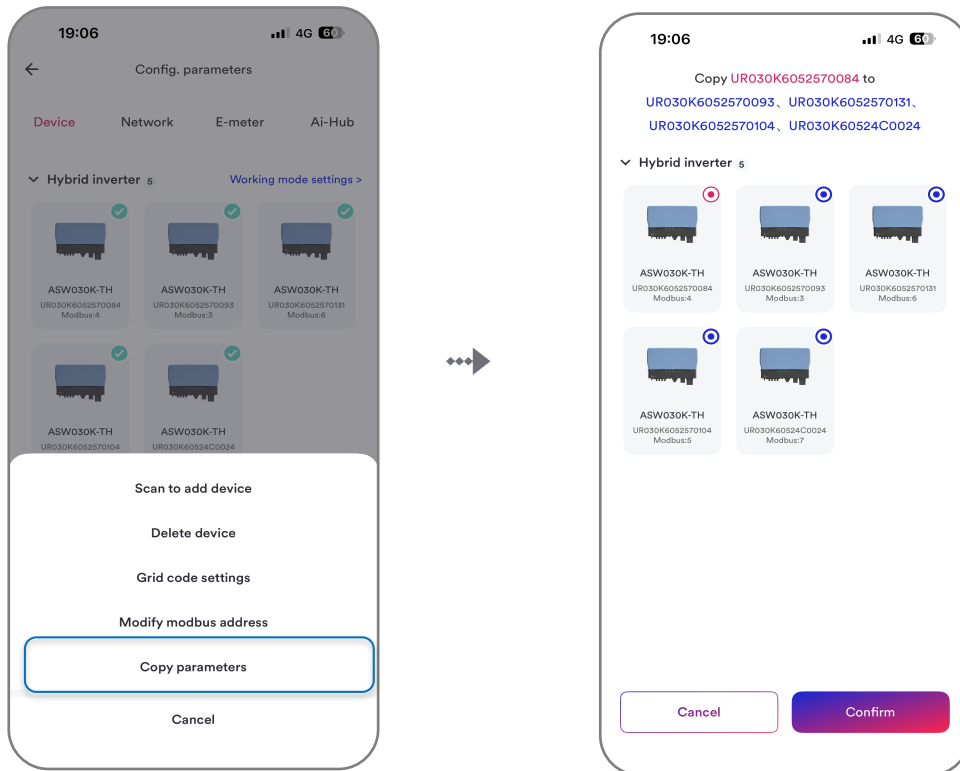

AI-HUB function settings:

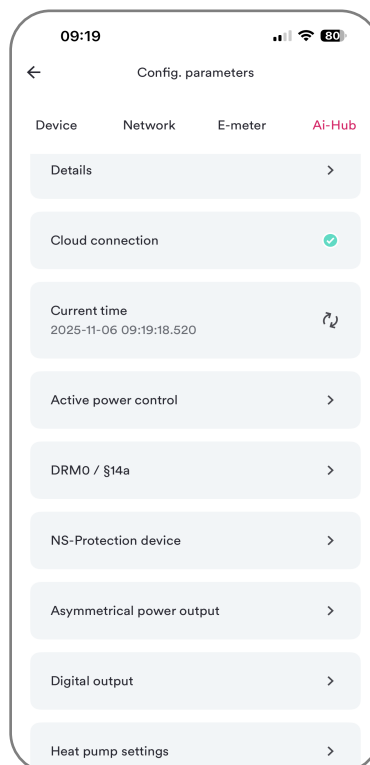

## 8.4 Activated Arc-fault Circuit Interrupter (AFCI)

The Solplanet App can establish a communication connection to the inverter via WLAN, thereby achieving near-end maintenance on the inverter. The Arc-fault Circuit Interrupter (AFCI) function can be activated on the Solplanet App.

Both the "Business user" and "End user" user groups can activate the AFCI function during PV plant commissioning. However, only the "Business user" can activate the AFCI function after the PV plant is operating normally.

### Procedure:

**Step 1:** Step 1: Enter the "Inverter Configuration" screen.

**Step 2:** Tap "Function Settings" to enter the next screen, and tap "AFCI" to enter the next screen.

**Step 3:** Tap the switch "Enable AFCI", then the automatic self-test function will be performed.

**Step 4:** The "Mode selection" and "Alarm clearing" can be chosen. If "Smart mode (recommended)" is chosen, the inverter will automatically analyze and determine whether the current fault is a genuine arc fault, and the error code will be sent only for genuine arc faults. If "Standard mode" is chosen, the error code will be sent immediately.



When the AFCI function is enabled for the first time, a self-test will be performed automatically before operation.

Additionally, the self-test will be performed once every 24 hours after the initial operation.

If choose to manually clear the alarm, the inverter will not restart after detecting an arc until the fault is cleared manually.

If you choose to automatically clear the alarm, the inverter will restart with a minimum delay time of 5 minutes after detecting an arc.

When interrupting the fifth time within a 24 h period, the inverter is only allowed to be reset manually.

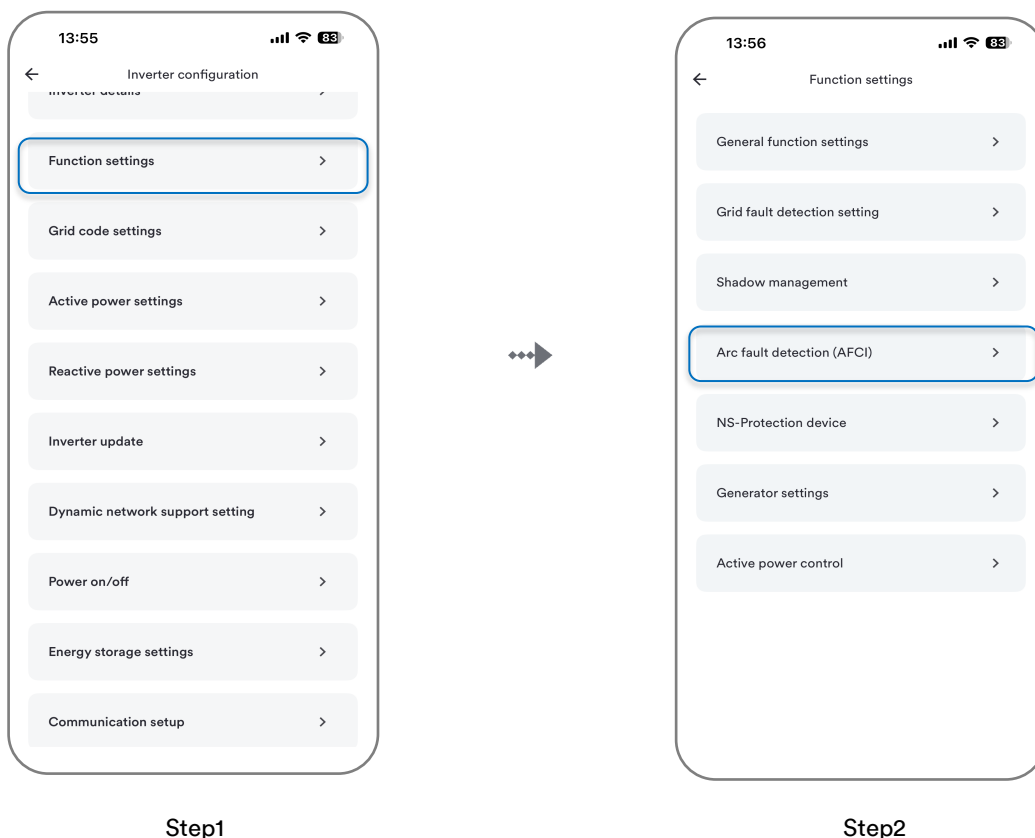



Step3

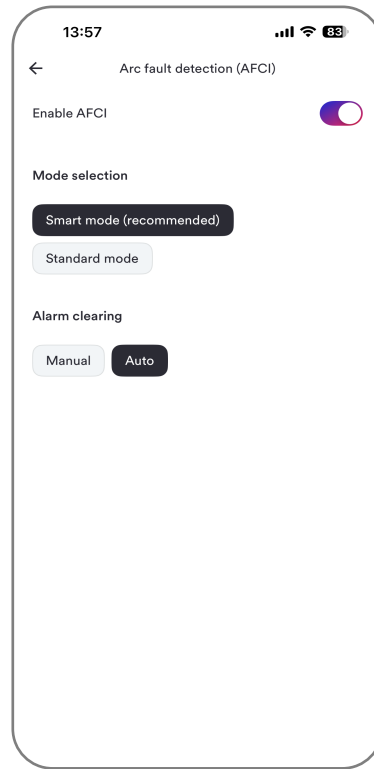

Step4

## 9 Decommissioning the product

### 9.1 Disconnecting the inverter from energy sources

Prior to performing any work on the product, always disconnect it from all energy sources as described in this section. Always adhere to the prescribed sequence.

#### **WARNING**

##### **Danger to life due to electric shock from destruction of the measuring device due to overvoltage!**

Overvoltage can damage a measuring device and result in voltage being present in the enclosure of the measuring device. Touching the live enclosure of the measuring device results in death or lethal injuries due to electric shock.

- Only use measuring devices with a DC input voltage range of 1100 V or higher.

#### **Procedure:**

**Step 1:** Turn off the miniature circuit breaker and secure against reconnection.

**Step 2:** Turn off the DC switch and secure against reconnection.

**Step 3:** Wait until the LEDs are off.

**Step 4:** Use a current clamp meter to ensure that no current is present in the DC cables.

#### **DANGER**

##### **Dangerous voltage due to two operating voltages!**

Severe injuries or death may occur if the cables and/or terminals/busbars in the device are touched. The discharge time of the capacitors is up to 5 minutes.

- Only appropriately qualified electricians authorized by the mains supply network operator are permitted to open and maintain the device.
- Before opening the device: Disconnect the AC and DC sides and wait at least 5 minutes.

#### **DANGER**

##### **Danger to life due to electric shock when touching exposed DC conductors or DC plug contacts if the DC connectors are damaged or loose!**

The DC connectors can break or become damaged, become free of the DC cables, or no longer be connected correctly if the DC connectors are released and disconnected incorrectly. This can result in the DC conductors or DC plug contacts being exposed. Touching live DC conductors or DC plug connectors will result in death or serious injury due to electric shock.

- Wear insulated gloves and use insulated tools when working on the DC connectors.
- Ensure that the DC connectors are in perfect condition and that none of the DC conductors or DC plug contacts are exposed.
- Carefully release and remove the DC connectors as described in the following instructions.

**Step 5:** Loosen and remove the DC connector. To do so, insert a flat-blade screwdriver or an angled screwdriver (blade width: 3.5mm) into one of the side slots and pull the DC connectors out.

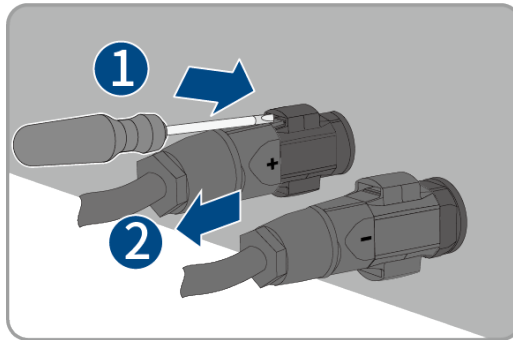

**Step 6:** Ensure that no voltage is present between the positive terminal and negative terminal at the DC inputs on the inverter side using a suitable measuring device.

**Step 7:** Loosen and remove the AC connector.

#### Unlock instructions

1. Unlock Terminal as shown.

2. Hold the main body and pull it back to complete the disassembly.

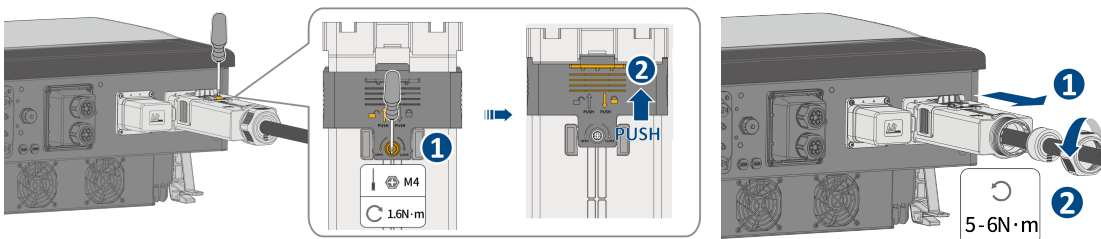

**Step 8:** Loosen and remove the LOAD / GEN connector.

#### Unlock instructions

1. Turn the nut in the opposite direction.

2. Press to the unlocking position with the built-in wrench, hold the main body and pull it back to complete the disassembly.

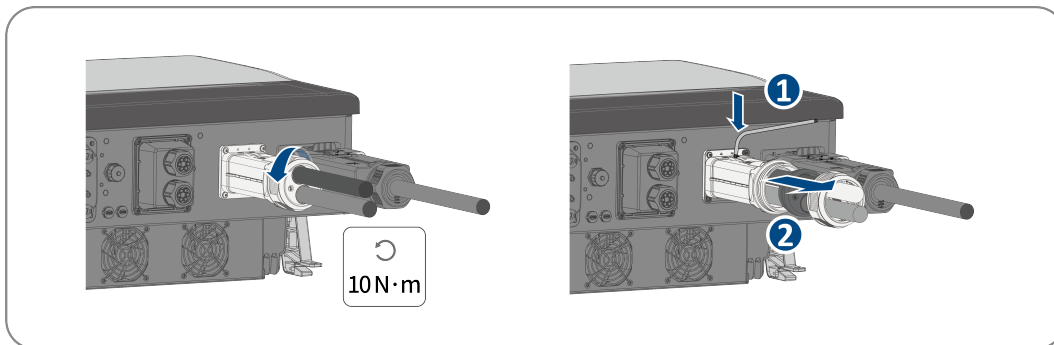

**Step 9:** Loosen and remove the battery connector.

#### Unlock instructions

If you need to remove the positive and negative battery connectors from the inverter battery connector input, use the disassembly lever hand insert the fixed bayonet as shown in the picture below and press down firmly, gently unplug the battery connector.

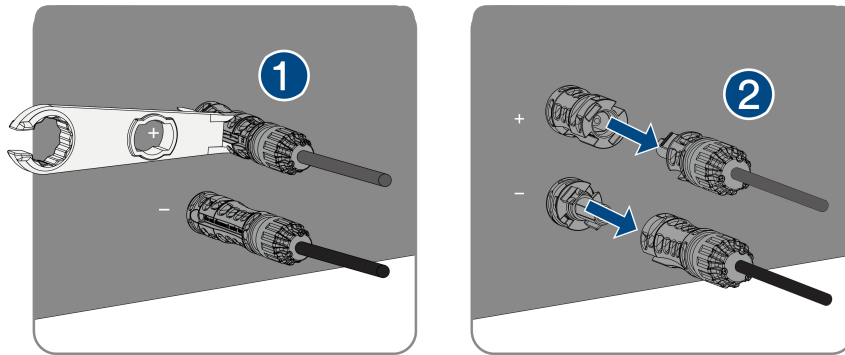

**Step 10:** Remove the communication cover. Remove the communication cable in reverse order by referring to 6.8 Communication equipment connection.

**Step 11:** Hold down the buckle on the side of the Ai-Dongle and pull out the Ai-Dongle terminal.

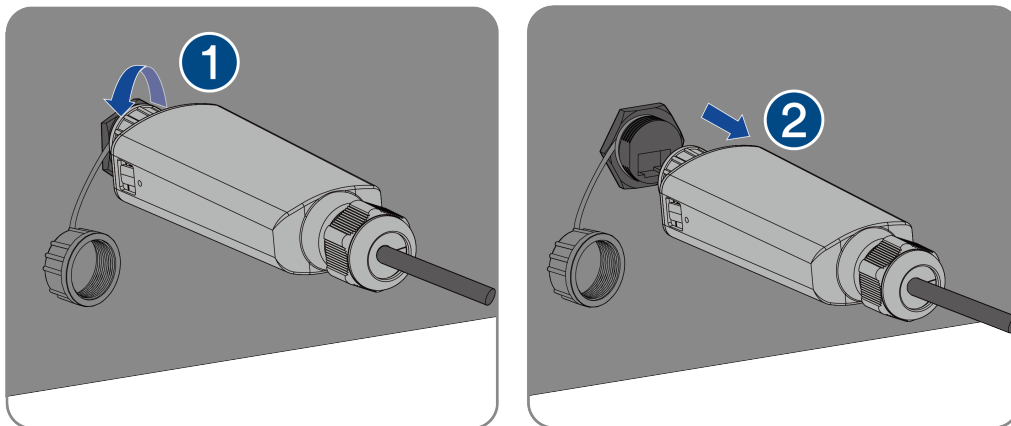

## 9.2 Dismantling the inverter

After disconnecting all electrical connections as described in Section 9.1, the inverter can be removed as follows:

### Procedure:

**Step 1:** Dismantle the inverter referring to “5.3 Mounting” in reverse steps.

**Step 2:** If necessary, remove the wall-mounting bracket from the wall.

**Step 3:** If the inverter will be reinstalled in the future, please refer to “3.2 Inverter Storage” for a proper preservation.

## 10 Technical data

### 10.1 ASW015/020/025/29.9/030K-TH

Type					
PV Port	ASW015K-TH	ASW020K-TH	ASW025K-TH	ASW29.9K-TH	ASW030K-TH
Maximum power of PV array	30000 Wp	40000 Wp	50000 Wp	59800 Wp	60000 Wp
Maximum input voltage	1000 V				
Minimum input voltage	95 V				
Start voltage	180 V				
Rated input voltage	630 V				
MPP voltage range	150 - 950 V				
MPP voltage range at Pnom	375-850 V	500-850 V	315-850 V	375-850 V	375-850 V
Maximum operating input current	20 A		40 A		
Maximum short circuit current (Isc PV)	25 A		50 A		
Number of independent MPP inputs	4				
Strings per MPP input	1		2		
Maximum inverter backfeed current to the array	0 A				
Surge protection	Type II, SPD				
Overvoltage category as per IEC 62109-1	II				
Battery Port	ASW015K-TH	ASW020K-TH	ASW025K-TH	ASW29.9K-TH	ASW030K-TH
Maximum voltage	800 V				
Voltage range	120 V to 800 V				
Maximum charge power from PV and grid	30000 W	40000 W	50000 W	59800 W	60000 W
Maximum charge power from grid	15000 W	20000 W	25000 W	29900 W	30000 W
Maximum discharge power	15000W	20000 W	25000 W	29900 W	30000 W
Maximum charge / discharge current	50 A / 50 A		2*50 A / 2*50 A		
Battery type	LiFePO4				
Overvoltage category as per IEC 62109-1	II				
Grid port	ASW015K-TH	ASW020K-TH	ASW025K-TH	ASW29.9K-TH	ASW030K-TH
Nominal output active power at 230 V	15000 W	20000 W	25000 W	29900 W	30000 W
Rated apparent power at $\cos\varphi = 1$	15000 VA	20000 VA	25000 VA	29900 VA	30000 VA
Maximum apparent power at $\cos\varphi = 1$	16500 VA	22000 VA	27500 VA	32890 VA	33000 VA
Nominal voltage	220 V / 380 V [3/N/PE] 230 V / 400 V [3/N/PE] 240 V / 415 V [3/N/PE]				
Voltage range	270-480 V (Phase to Phase)				
Nominal frequency	50 Hz/60 Hz				
Frequency range	45-55 Hz/55-65 Hz				
Rated output current at 220 V	22.7 A	30.3 A	37.9 A	45.3 A	45.5 A
Rated output current at 230 V	21.7 A	29.0 A	36.2 A	43.3 A	43.4 A
Rated output current at 240 V	20.8 A	27.8 A	34.7 A	41.5 A	41.7 A
Rated output apparent power	15000 VA	20000 VA	25000 VA	29900 VA	30000 VA
Maximum output apparent power	16500 VA	22000 VA	27500 VA	32890 VA	33000 VA
Maximum continuous output current	23.9 A	31.9 A	39.8 A	47.6 A	47.8 A

Max. input power from grid	30000 W	40000 W	50000 W	50000 W	50000 W
Max. input current from grid	43.5 A	58.0 A	72.5 A	72.5 A	72.5 A
Contribution to peak short-circuit current I <sub>p</sub>	130 A	130 A	150 A	150 A	150 A
Initial short-circuit alternating current (I <sub>k</sub> " first single period effective value)	23.9 A	31.9 A	39.8 A	47.6 A	47.8 A
Short circuit current continuous (I <sub>k</sub> " max output fault current)	23.9 A	31.9 A	39.8 A	47.6 A	47.8 A
Inrush current	< 20 % of nominal AC current for a maximum of 10ms				
Total harmonic distortion of the output current with total harmonic distortion of the AC voltage <2%, and AC power >50% of the rated power	< 3 % (of nominal power)				
Power factor range	0.8 inductive ... 0.8 capacitive				
Number of feed-in phase	3P				
Recommended rated current of AC circuit breaker	63 A	80 A	100 A	100 A	100 A
Surge protection	MOV /SPD (Type II ,optional)				
Overvoltage category as per IEC 62109-1	III				
<b>EPS port</b>	<b>ASW015K-TH</b>	<b>ASW020K-TH</b>	<b>ASW025K-TH</b>	<b>ASW29.9K-TH</b>	<b>ASW030K-TH</b>
Nominal voltage	220 V / 380 V [3/N/PE] 230 V / 400 V [3/N/PE] 240 V / 415 V [3/N/PE]				
Nominal frequency	50 Hz / 60 Hz				
Rated output apparent power	15000 VA	20000 VA	25000 VA	29900 VA	30000 VA
Maximum output apparent power during on-grid mode	16500 VA	22000 VA	27500 VA	32890 VA	33000 VA
Maximum output apparent power during off-grid mode	16500 VA	22000 VA	27500 VA	32890 VA	33000 VA
Maximum peak output apparent power during off-grid mode (< 10 second)	30000 VA	40000 VA	45000 VA	45000 VA	45000 VA
Maximum continuous output current	23.9 A	31.9 A	39.8 A	47.6 A	47.8 A
Power Factor Range (off-grid)	0.8 inductive ... 0.8 capacitive				
Overvoltage category as per IEC 62109-1	III				
<b>Generator port</b>	<b>ASW015K-TH</b>	<b>ASW020K-TH</b>	<b>ASW025K-TH</b>	<b>ASW29.9K-TH</b>	<b>ASW030K-TH</b>
Max. input apparent power (off-grid)	18000 VA	24000 VA	30000 VA	35880 VA	36000 VA
Max. continuous input current (off-grid)	26.1 A	34.8 A	43.5 A	52 A	52.2 A
Max. charging power of battery	15000 W	20000 W	25000 W	29900 W	30000 W
Power factor range (off-grid)	0.8 inductive ... 0.8 capacitive				
Nominal voltage	220 V / 380 V [3/N/PE] 230 V / 400 V [3/N/PE] 240 V / 415 V [3/N/PE]				
Nominal frequency	50 Hz / 60 Hz				
<b>Efficiency</b>	<b>ASW015K-TH</b>	<b>ASW020K-TH</b>	<b>ASW025K-TH</b>	<b>ASW29.9K-TH</b>	<b>ASW030K-TH</b>
Maximum efficiency	98.0%		98.4%		
European weighted efficiency	97.2%		97.9%		

(1) The voltage range meets the requirements of the corresponding national grid code.

(2) The frequency range meets the requirements of the corresponding national grid code.

(3) Only the three-phase generator are supported.

## 10.2 General data

Type	ASW015K-TH	ASW020K-TH	ASW025K-TH	ASW29.9K-TH	ASW030K-TH
Width × height × depth	769 mm / 491 mm / 285 mm				
Weight	50.5kg		58kg		
Climatic category in accordance with IEC 60721-3-4	4K4H				
Pollution degree outside the enclosure	3				
Pollution degree inside the enclosure	2				
Operating temperature range	-30 °C ... +60 °C				
Allowable relative humidity range (non-condensing)	0 ... 100%				
Maximum operating altitude above mean sea level	4000 m				
Typical noise emission	< 35 dB(A)@1 m		< 55 dB(A)@1 m		
Self-consumption (night)	< 10 W				
Topology	Non-isolated				
Cooling method	Smart cooling				
Degree of protection for electronics in accordance with IEC 60529	IP66				
Protection class in accordance with IEC 62109-1	I				
Distribution system	TN-C-system, TN-C-S-system, TN-S-system, TT-system				
Display	LED indicator & APP				
Demand response mode in accordance with AS/NZS 4777.2	DRM0				
Earth Fault Alarm	Cloud based, Visible				
Export active power output	Via connecting Smart meter				
Communication Interfaces	Dongle: Wi-Fi (2.4 GHz) / LAN (100 Mbps) Inverter: RS485 (Modbus RTU), Modbus TCP				
Radio technology	WLAN 802.11 b/g/n				
Radio spectrum	2.4 GHz				
Maximum transmission power	100 mW				
Mounting information	Wall Mounting Bracket				
DC connector type	Sunclix				
AC Connector type	CNNT DSTB38-05				
EPS/GEN Connector type	HDB-76i10				
Battery Connector type	MC4				

## 10.3 Protective device

Protective devices	ASW015K-TH	ASW020K-TH	ASW025K-TH	ASW29.9K-TH	ASW030K-TH
DC reverse polarity protection	Integrated				
DC isolator	Integrated				
AC short- circuit protection	Integrated				
Ground fault monitoring	Integrated				

All-pole sensitive residual current monitoring unit	Integrated
Active anti-islanding protection	Integrated
PV string current monitoring	Integrated
DC current injection monitoring	Integrated
DC surge protection	Integrated
AC surge protection	Integrated

## 11 Troubleshooting

When the PV system does not operate normally, we recommend the following solutions for quick troubleshooting. If an error or warning occurs, there will have "Event Messages" display in the LCD screen and monitor tools. The corresponding corrective measures are as follows:

Error code	Message	Corrective measures
3-5 8,9	Permanent Fault	<ul style="list-style-type: none"> <li>• Disconnect the inverter from the battery, the grid and the PV array and reconnect after 3 minutes.</li> <li>• If this fault is still being shown, contact the service.</li> <li>• The inverter temperature should above <math>-40^{\circ}\text{C}</math>.</li> </ul>
10	Device fault	<ul style="list-style-type: none"> <li>• Disconnect the inverter from the battery, the grid and the PV array and reconnect after 3 minutes.</li> <li>• If this fault is still being shown, contact the service.</li> <li>• The inverter temperature should above <math>-40^{\circ}\text{C}</math>.</li> </ul>
12	HW output over current	<ul style="list-style-type: none"> <li>• Disconnect the inverter from the AC grid, PV module, battery and reconnect after 5 minutes, check if it is solved.</li> <li>• If not, disconnect the load, and restart the inverter to check that it is solved.</li> <li>• If the fault disappears, then connect the load one by one to check which load result this fault.</li> <li>• Claim an exchange of the inverter if complete the above guide with fault is still there.</li> </ul>
33	Grid frequency fault	<ul style="list-style-type: none"> <li>• Check the grid and EPS frequency and observe how often major fluctuations occur. Contact customer service if EPS frequency abnormal. If this fault is caused by frequent fluctuations, try to modify the operating parameters after informing the grid operator first.</li> </ul>
34	Grid voltage fault	<ul style="list-style-type: none"> <li>• Check the grid voltage and grid connection on inverter.</li> <li>• Check the grid voltage at the point of connection of inverter.</li> <li>• If the grid voltage is outside the permissible range due to local grid conditions, try to modify the values of the monitored operational limits after informing the electric utility company first. If the grid voltage lies within the permitted range and this fault still occurs, please call service.</li> </ul>
36	GFCI fault	<ul style="list-style-type: none"> <li>• Make sure the grounding connection of the inverter is reliable.</li> <li>• Make a visual inspection of all PV cables and modules.</li> <li>• If this fault is still shown, contact the service.</li> </ul>
37	PV over voltage fault	<ul style="list-style-type: none"> <li>• Check the open-circuit voltages of the strings and make sure it is below the maximum DC input voltage of the inverter. If the input voltage lies within the permitted range and the fault still occurs, please call service.</li> </ul>
38	Isolation fault	<ul style="list-style-type: none"> <li>• Check the PV array's insulation to ground and make sure that the insulation resistance to ground is greater than 50 Kohm. Otherwise, make a visual inspection of all PV cables and modules.</li> <li>• Make sure the grounding connection of the inverter is reliable.</li> <li>• If this fault occurs often, contact the service.</li> </ul>
40	Over temperature fault	<ul style="list-style-type: none"> <li>• Check whether the airflow to the heat sink is obstructed.</li> <li>• Check whether the ambient temperature around the inverter is too high.</li> </ul>
48	10 minutes average over voltage fault	<ul style="list-style-type: none"> <li>• Check the grid voltage at the point of connection of inverter.</li> <li>• If the grid voltage is outside the permissible range due to local grid conditions, try to modify the values of the monitored operational limits after informing the electric utility company first.</li> <li>• If the grid voltage lies within the permitted range and this fault still occurs, please call service.</li> </ul>
65	PE wire connection fault	<ul style="list-style-type: none"> <li>• Check if the ground line is connected to the inverter.</li> <li>• Ensure the grounding connection of the inverter is connected and reliable.</li> <li>• If this fault occurs often, contact Solplanet service.</li> </ul>
69	External input signal fault	<ul style="list-style-type: none"> <li>• If NS protection function is not needed, this function maybe enabled by mistake, disable this by APP.</li> <li>• If NS protection function is needed, check signal wire connection is right on Terminal block</li> </ul>

		<ul style="list-style-type: none"> <li>G/K's PIN1&amp;PIN2, if connection is right, use multimeter measure Terminal block G/K's PIN1&amp;PIN2 power voltage should lie in range of 10-24Vd.c..</li> <li>If this fault occurs often, contact Solplanet service.</li> </ul>
70	AFCI self test fail	<ul style="list-style-type: none"> <li>Please check the external wiring of the product (wire sequence error, bad terminal contact, wire break, etc.), and exclude other anomalies.</li> <li>If the problem is still not solved, contact Solplanet service.</li> </ul>
71	AFCI fault	<ul style="list-style-type: none"> <li>Please check the external wiring of the product (wire sequence error, bad terminal contact, wire break, etc.), and exclude other anomalies.</li> <li>If the problem is still not solved, contact Solplanet service.</li> </ul>
76	Generator Voltage or Fac Out of Range	<ul style="list-style-type: none"> <li>Check whether the diesel generator works properly.</li> <li>Check that the Gen-port is correctly connected.</li> <li>Check whether the diesel generator is connected but set the port mode to smart load mode.</li> </ul>
77	Generator Phase sequence error	<ul style="list-style-type: none"> <li>Check that the phase sequence of the connector connection is consistent with that of the power grid.</li> </ul>
78	Generator or smart load Overloaded	<ul style="list-style-type: none"> <li>In generator mode: <ul style="list-style-type: none"> <li>a) Check the maximum power setting of the generator machine.</li> <li>b) Check whether the load power exceeds the maximum limit.</li> </ul> </li> <li>In smart load mode: <ul style="list-style-type: none"> <li>a) Check whether the smart load power exceeds the maximum limit.</li> </ul> </li> </ul>
80	Software Version Mismatch	<ul style="list-style-type: none"> <li>Check whether the firmware versions of the inverter and the Dongle match, if not, update the corresponding firmware.</li> <li>If the problem is still not solved, contact Solplanet service.</li> </ul>
W177	Battery 1 Communication or Power Cable Disconnect	<ul style="list-style-type: none"> <li>Check whether the power cable of Battery 1 is disconnected.</li> <li>Check whether the communication cable of battery 1 is disconnected.</li> <li>If the problem is still not solved, contact Solplanet service.</li> </ul>
W189	Battery 2 Communication or Power Cable Disconnect	<ul style="list-style-type: none"> <li>Check whether the power cable of Battery 2 is disconnected.</li> <li>Check whether the communication cable of battery 2 is disconnected.</li> <li>If the problem is still not solved, contact Solplanet service.</li> </ul>
W192	Meter or CT loss	<ul style="list-style-type: none"> <li>If meter is enable, check the meter screen, if there is no phone symbol on meter screen check the communication connection of meter; if there is phone symbol on meter screen, please re-plug the connector of meter.</li> <li>If this fault occurs often, contact the service.</li> </ul>
W196	Incorrect connection of battery communication or power cable	<ul style="list-style-type: none"> <li>Check whether the power cable and communication cable of battery 1 and battery 2 are connected in reverse.</li> <li>If the problem is still not solved, contact Solplanet service.</li> </ul>

Contact the service if you meet other problems or error codes not described in the table.

## 12 Maintenance

### 12.1 Cleaning the contacts of the DC switch

#### **DANGER**

##### High voltage of PV string may cause life danger!

If the DC connector is disconnected while the PV inverter is working, electric arc may occur, causing electric shock and burns.

- Please disconnect the circuit breaker on the AC side first, and then disconnect the DC switch.

To ensure the normal operation of the DC input switch, it is necessary to clean the DC switch contacts every year.

#### **Procedure:**

**Step 1:** Disconnect the AC disconnecter and prevent accidental restart.

**Step 2:** Rotate the DC switch handle from the “ON” position to the “OFF” position for 5 times.

### 12.2 Cleaning air inlet and outlet

#### **CAUTION**

##### Hot enclosure or heat sink may cause personal injury!

When the inverter is working, the temperature of the enclosure or heat sink may be higher than 70 °C and may cause injury due to burns.

- Before cleaning the air outlet, shut down the machine and wait for about 30 minutes until the inverter is safe to touch.

A huge amount of heat is generated in the process of running the inverter. The inverter adopts a controlled forced-air cooling method. In order to maintain good ventilation, please check to make sure the air inlet and outlet are not blocked.

#### **Procedure:**

**Step 1:** Disconnect the AC side circuit breaker and ensure that it cannot be accidentally reconnected.

**Step 2:** Disconnect the DC switch, rotate the DC switch handle from the “ON” position to the “OFF” position.

**Step 3:** Clean the air inlet and outlet of the inverter with a soft brush.

## 13 Recycling and disposal

Dispose of the packaging and replaced parts according to the rules applicable in the country where the device is installed.



Do not dispose of the product together with the household waste but in accordance with the disposal regulations for electronic waste applicable at the installation site.

## 14 EU declaration of conformity

Within the scope of the EU directives

- Radio Equipment Directive 2014/53/EU (L 153/62-106. May 22. 2014) (RED)
- Restriction of the use of certain hazardous substances 2011/65/EU (L 174/88, June 8, 2011) and 2015/863/EU (L 137/10, March 31,2015) (RoHS)



AISWEI Technology Co., Ltd. confirms herewith that the inverters described in this manual are in compliance with the fundamental requirements and other relevant provisions of the above mentioned directives.

The entire EU Declaration of Conformity can be found at [www.solplanet.net](http://www.solplanet.net).

## 15 Service and warranty

If you have any technical problems concerning our products, please contact Solplanet service. We require the following information in order to provide you with the necessary assistance:

- Inverter device type
- Inverter serial number
- Type and number of connected PV modules
- Error code
- Mounting location
- Installation date
- Warranty card

Warranty terms and conditions can be downloaded at [www.solplanet.net](http://www.solplanet.net).

When the customer needs warranty service during the warranty period, the customer must provide a copy of the invoice, factory warranty card, and ensure the electrical label of the inverter is legible. If these conditions are not met, Solplanet has the right to refuse to provide with the relevant warranty service.

## 16 Contact

EMEA

Service email: [service.EMEA@solplanet.net](mailto:service.EMEA@solplanet.net)

APAC

Service email: [service.APAC@solplanet.net](mailto:service.APAC@solplanet.net)

LATAM

Service email: [service.LATAM@solplanet.net](mailto:service.LATAM@solplanet.net)

AISWEI Technology Co., Ltd.

Hotline: +86 400 801 9996

Add.: No. 18, Alley 600, Nanchezhan Road, Huangpu District, Shanghai, China

<https://solplanet.net/contact-us/>

Scan QR code:



Android

Scan QR code:



iOS

