

SOFAR

# USER MANUAL

ESI-5...12K-T1



Shenzhen SOFARSOLAR Co., Ltd.

**Shenzhen SOFARSOLAR Co., Ltd.**

11/F, Gaoxinqi Technology Building,  
District 67, XingDong Community, XinAn Street,  
Bao'An District, Shenzhen, China

Email: [service@SOFAR.com](mailto:service@SOFAR.com)

Web: [www.sofarsolar.com](http://www.sofarsolar.com)

EU Representative Information: SofarSolar GmbH.

Krämerstraße 20 ,72764 Reutlingen,Germany

Tel: +49 (0)7121 31767-0

E-Mail: [europe@sofarsolar.com](mailto:europe@sofarsolar.com)

Document number

Issue 31 | 07 .2025

English

# CONTENT

<b>1</b>	<b>About this manual</b>	<b>1</b>
1.1	Copyright declaration	1
1.2	Presentation of warnings	2
1.3	Presentation of action instructions	3
1.4	Note	3
<b>2</b>	<b>Basic safety information</b>	<b>4</b>
2.1	Safety information	4
2.2	Symbols and signs	8
<b>3</b>	<b>Product features</b>	<b>11</b>
3.1	Product information	11
3.2	Product dimensions	12
3.3	Labelling on the device	13
3.4	Functional features	13
3.5	Application modes	15
<b>4</b>	<b>Installation</b>	<b>20</b>
4.1	Installation information	20
4.2	Installation procedure	20
4.3	Examination before installation	21
4.4	Connections	24
4.5	Tools	25
4.6	Installation Environment Requirements	26
4.7	Installation location	26
4.8	Unpacking the inverter	27
4.9	Safety instructions	28
4.10	Wiring overview	31
4.11	System Electrical Topology	32
4.12	Smart Meter / CT	34
4.13	Electrical connection	37
4.14	Connecting the PE cables	38

4.15	Connecting the DC lines for the PV modules and battery	39
4.16	Connecting the AC power cables	42
4.17	AC connector installation	43
4.18	Communication interfaces	45
4.19	Feed-in limitation function	59
4.20	System monitoring	60
4.21	Installation of the WiFi	60
<b>5</b>	<b>Energy storage system construction</b>	<b>68</b>
5.1	Energy storage system with BTS 5K batteries	68
<b>6</b>	<b>Commissioning the inverter</b>	<b>77</b>
6.1	Safety test before commissioning	77
6.2	Double Check	77
6.3	Starting the inverter	77
6.4	Initial setup	78
<b>7</b>	<b>Operation of the device</b>	<b>80</b>
7.1	Control panel and display field	80
7.2	Standard display	81
7.3	Work modes	82
7.4	Menu structure	92
<b>8</b>	<b>Troubleshooting handling</b>	<b>102</b>
8.1	Troubleshooting	102
8.2	Error list	104
8.3	Maintenance	117
<b>9</b>	<b>Datasheet</b>	<b>118</b>

# 1 About this manual

This Installation and user manual (hereinafter referred to as the manual) describes the installation, electrical connection, commissioning, maintenance and fault elimination procedures of following products:

ESI-5K-TI, ESI-6.5K-TI, ESI-8K-TI, ESI-9.9K-TI-A, ESI-10K-TI,  
ESI-12K-TI

- ▶ Carefully read this manual before use!
- ▶ Treat this manual as an integral component of the device.
- ▶ Keep this manual in close proximity to the device, including when it is handed over to another user or moved to a different location.

This manual contains important safety information on installation, operation and maintenance of the device.

- ▶ Read and observe all given safety information.

The products, services or features you purchased shall be subject to the company's commercial contracts and terms. All or part of the products and services described in this document may not within the scope of your purchase. Unless additional terms and conditions in your contract, the company does not make any statement or guarantee on the contents of this document.

## 1.1 Copyright declaration

The copyright of this manual is owned by SOFAR. It may not be copied – neither partially nor completely – by companies or individuals (including software, etc.) and must not be reproduced or distributed in any form, or with the appropriate means.

SOFAR reserves the right to final interpretation. This manual may be amended following feedback from users or customers.

Consult our website at: <https://www.SOFAR.com> for the latest version.

## 1.2 Presentation of warnings

This manual contains information on safe operation and uses symbols to ensure the safety of persons and property as well as the efficient operation of the inverter.

- ▶ Read through the following symbol explanations carefully in order to prevent injury or property damage.

### 1.2.1 Warnsymbol

	<p>The general danger symbol warns of risk of serious injury when used with the signal words CAUTION, WARNING, and DANGER.</p>
---	--

### 1.2.2 Signalwords

	<p>Indicates a hazardous situation which, if not avoided, will result in death or serious injury.</p>
<p><b>WARNING</b></p>	<p>Indicates a hazardous situation which, if not avoided, could result in death or serious injury.</p>
<p><b>CAUTION</b></p>	<p>Indicates a hazardous situation which, if not avoided, could result in minor or moderate injury.</p>
	<p>Indicates a danger that results in damage to or destruction of the inverter.</p>

### 1.2.3 Sectional warnings

Sectional warnings refer to a complete section and are structured as follows:

 <b>WARNING</b>
<p><b>Type and source of danger</b></p> <p><b>Consequences for non observance</b></p> <ul style="list-style-type: none"> <li>▶ Avoiding the danger</li> </ul>

### 1.2.4 Embedded warnings

Embedded warnings are part of an action sequence and are placed right before the dangerous step.

**WARNING** Combination of type/source of danger, consequences for non observance and avoiding the danger.

### 1.3 Presentation of action instructions

This table shows the sequence of Action steps:

Symbol	Function
✓	This describes an action requirement
1. 2. 3.	This is the sequence of action steps that must be followed step by step
▶	This is a single action step
↳	This describes the result of the action

### 1.4 Note

Notes are presented in a grey bar.

- ▶ Provides tips essential to the optimal operation of the product.

## 2 Basic safety information



- ▶ If you have any questions or problems after reading the following information, please contact SOFAR

This chapter details the safety information pertaining to the installation and operation of the device.

### 2.1 Safety information

Read and understand the instructions within this manual and familiarise yourself with the relevant safety symbols in this chapter before beginning with the installation of the device and eliminating any faults.

Before connecting to the power grid, you must obtain official authorisation from the local power grid operator in accordance with the corresponding national and state requirements. Furthermore, operation may only be carried out by qualified electricians.

Please contact the nearest authorised service centre if any maintenance or repairs are required. Please contact your dealer to obtain information about your nearest authorised service centre. Do NOT carry out repairs on the device yourself; this may lead to injury or property damage.

Before installing the device or carrying out maintenance on it, you must open the DC switch in order to interrupt the DC voltage of the PV generator. You can also switch off the DC voltage by opening the DC switch in the generation junction box. Not doing this may result in serious injury.

### 2.1.1 Qualified personnel

Personnel tasked with the operation and maintenance of the device must have the qualifications, competence and experience required to perform the described tasks, while also being capable of fully understanding all instructions contained within the manual. For safety reasons, this inverter may only be installed by a qualified electrician who:

- ▶ -has received training on occupational safety, as well as the installation and commissioning of electrical systems
- ▶ -is familiar with the local laws, standards and regulations of the grid operator.

SOFAR assumes no responsibility for the destruction of property or any injuries to personnel caused by improper usage.

### 2.1.2 Installation requirements

Please install the inverter according to the information contained in the following section. Mount the inverter to a suitable object with a sufficient load-bearing capacity (e.g. walls, PV frames etc.) and ensure that the inverter is upright. Choose a suitable place for the installation of electrical devices. Ensure that there is sufficient space for an emergency exit which is suitable for maintenance. Ensure sufficient ventilation in order to guarantee an air circulation for the cooling of the inverter.

### 2.1.3 Transport requirements

The factory packaging is specifically designed to prevent transport damage, i.e. violent shocks, moisture and vibrations. However, the device must not be installed if it is visibly damaged. In this case, notify the responsible transport company immediately.

### 2.1.4 Labelling on the device

The labels must NOT be concealed by items and foreign objects (rags, boxes, devices, etc.); they must be regularly cleaned and kept clearly visible at all times.

## 2.1.5 Electrical connection

Observe all applicable electrical regulations when working with the Solar inverter.

### DANGER

#### **Dangerous DC voltage**

- ▶ Before establishing the electrical connection, cover the PV modules using opaque material or disconnect the PV generator from the inverter. Solar radiation will cause dangerous voltage to be generated by the PV generator!

### DANGER

#### **Danger through electric shock!**

- ▶ All installations and electrical connections may only be carried out by trained electricians!

### NOTICE

#### **Authorisation for grid feed-in**

- ▶ Obtain authorisation from the local power grid operator before connecting the inverter to the public power grid.

- ▶ Do not open the inverter or remove any of the labels. Otherwise, SOFAR shall assume no guarantee.

## 2.1.6 Operation

### DANGER

#### **Electric shock**

- ▶ Contact with the electrical grid or the device's terminals may result in an electric shock or fire!
- ▶ Do not touch the terminal or the conductor which is connected to the electrical grid.
- ▶ Follow all instructions and observe all safety documents that refer to the grid connection.

### CAUTION

#### **Burning due to hot housing**

- ▶ While the inverter is being operated, several internal components will become very hot.
- ▶ Please wear protective gloves!
- ▶ Keep children away from the device!

## 2.1.7 Repair and maintenance

### DANGER

#### **Dangerous voltage!**

- ▶ Before carrying out any repair work, first switch off the AC circuit breaker between the inverter and power grid, and then the DC switch.
- ▶ After switching off the AC circuit breaker and the DC switch, wait a minimum of 5 minutes before starting any maintenance or repair work.

**NOTICE****Unauthorised repairs!**

- ▶ Following the elimination of any faults, the inverter should be fully functional once more. Should any repairs be required, please contact a local authorised service centre.
- ▶ The internal components of the inverter must NOT be opened without the relevant authorisation. Shenzhen SOFAR Co., Ltd. assumes no responsibility for any resulting losses or defects.

## 2.2 Symbols and signs

**⚠ CAUTION****Beware of burning hazards due to the hot housing!**

- ▶ While the inverter is in operation, only touch the display and the buttons, as the housing can become hot.

**NOTICE****Implement earthing!**











- ▶ The PV generator must be earthed in accordance with the requirements of the local power grid operator!
- ▶ For reasons of personal safety, we recommend that all PV module frames and inverters of the PV system are reliably earthed.



**⚠ WARNING****Damage due to overvoltage**

- ▶ Ensure that the input voltage does not exceed the maximum permissible voltage. Overvoltage may cause long-term damage to the inverter, as well as other damage that is not covered by the warranty!

## 2.2.1 Symbols on the inverter

Several symbols pertaining to safety can be found on the inverter. Please read and understand the content of these symbols before starting the installation.

Symbol	Description
	Residual voltage is present in the inverter! Before opening the inverter, you should wait fifteen minutes to ensure that the capacitor has been fully discharged.
	Caution! Danger through electric shock
	Caution! Hot surface
	The product is compliant with EU guidelines
	Earthing point
	Please read the manual before installing the inverter
	Device degree of protection according to EN 60529
	Positive and negative poles of the DC input voltage
	Need to be moisture-proof and wet to store items in a clean and dry place
	The inverter must always be transported and stored with the arrows pointing upward
	The cartons are packed with fragile goods and should be handled with care

	<p>A maximum of 6 layers can be stacked during the stacking process</p>
	<p>The material can be recycled and recycled.</p>
	<p>Do not dispose of the equipment with household garbage at its end of life. Dispose of it according to local laws and regulations or send it to the manufacturer.</p>

### 3 Product features

This chapter describes the product features, dimensions and efficiency levels.

#### 3.1 Product information

The ESI-5...12K-TI is a grid-coupled PV and energy storing inverter which can also supply energy in stand-alone operation.

The ESI-5...12K-TI has integrated energy management functions which cover a wide range of application scenarios.

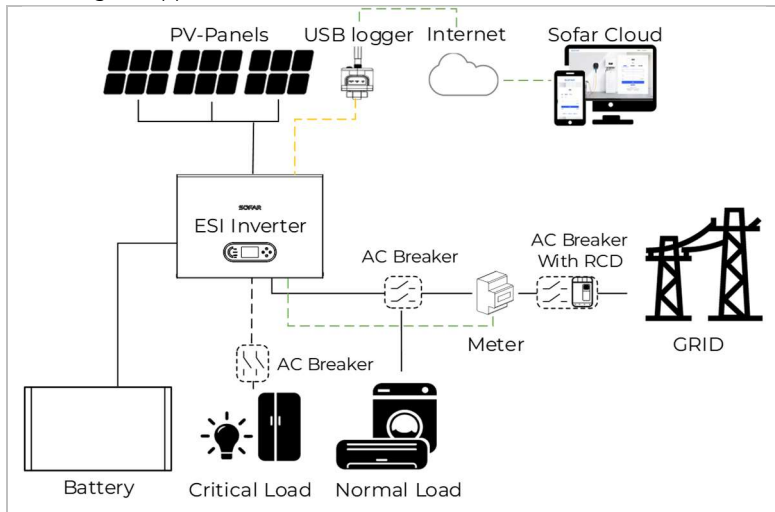

Figure 3-1 ESI-5...12K-TI inverter system diagram

ESI-5...12K-TI inverters may only be used with photovoltaic modules which do not require one of the poles to be earthed. In normal operation, the operating current must not exceed the limits specified within the technical data.

The selection of the optional inverter parts must be determined by a qualified technician who has good knowledge of the installation conditions.

### 3.2 Product dimensions

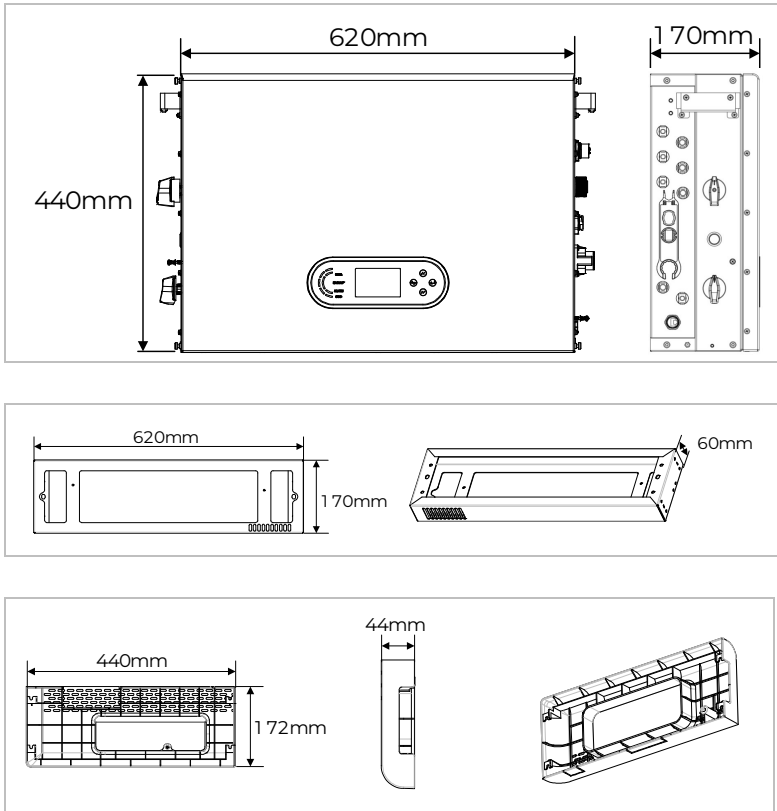

Figure 3-2 Dimensions



discharge current of 19.5 A, the ESI-8K-T1 has a maximum discharge current of 24 A, the ESI-9.9K-T1 has a maximum discharge current of 29.7 A, and the ESI-10K-T1 has a maximum discharge current of 30 A, the ESI-12K-T1 maximum discharge current is 30A.

- ▶ Wide battery input voltage range (350-435 V).
- ▶ The BACKUP output can be connected to unbalanced loads.
- ▶ Up to 6 Inverters can be connected in parallel in master / slave mode via the link cable if used on-grid mode.
- ▶ Up to 3 inverters with Storage System can operate in parallel in master/slave when the BACKUP Mode (off- Grid) is used.
- ▶ BACKUP Mode always needs to be connected to a battery or PV system, otherwise it will not be operated.
- ▶ If there is more than one hybrid inverter in the system, they must be connected in parallel (Master-Slave mode). For maximum system performance and to prevent in future imbalances between the towers, the hybrid inverters must be identical to each other (i.e., same size, number and models of batteries). This mode makes it possible to synchronise the charging and discharging power of multiple interconnected hybrid inverters in order to maximise self-consumption.
- ▶ Additional PV string inverter can be integrated in the system using chint direct connected electric meter DTSU 666 energy meters. Up to 3 external PV meters can be connected, meter ID can be used 2,3,4.
- ▶ Monitoring via Wi-Fi/4G, optionally via Bluetooth.

### 3.4.2 Electrical block diagram

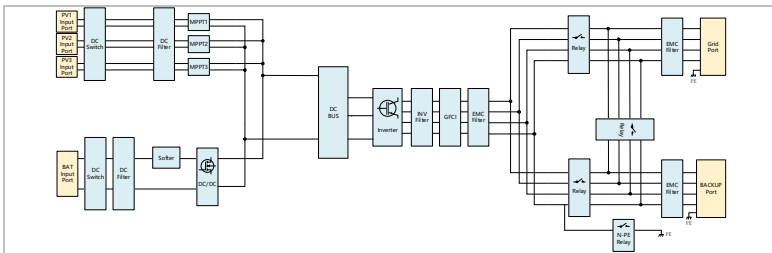

Figure 3-4 Electrical schematic diagram

### 3.5 Application modes

#### 3.5.1 Typical energy storage system

A typical energy storage system with PV panels and battery unit(s), connected to the grid.

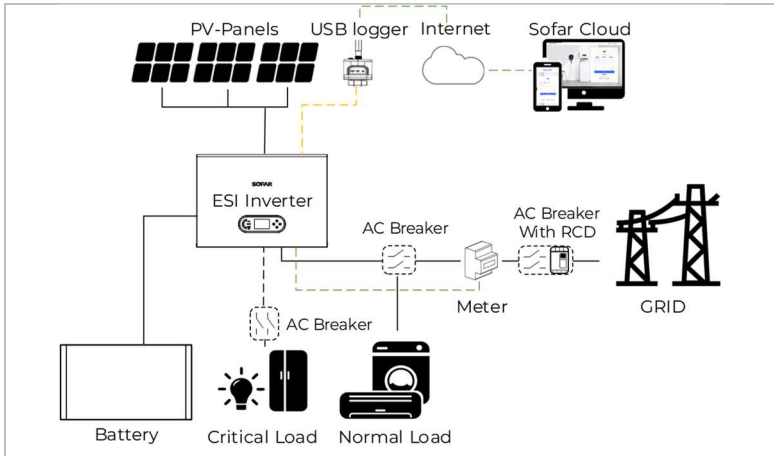

Figure 3-5 Typical energy storage system

#### 3.5.2 System without PV connection

In this configuration, there are no PV panels connected and the battery is charged through the grid connection.

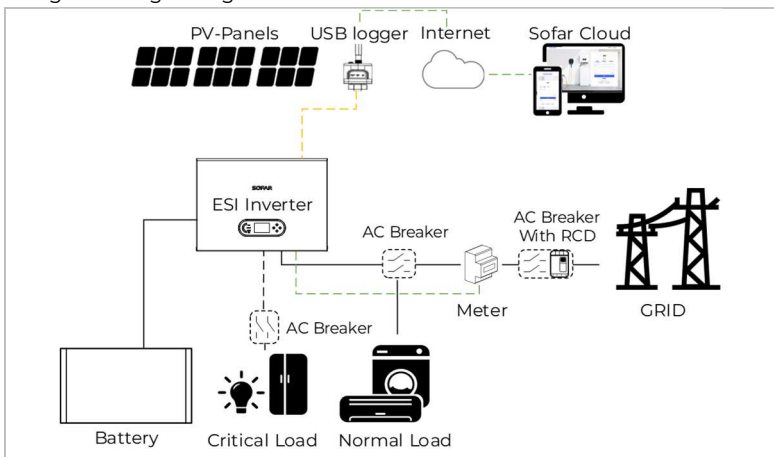

Figure 3-6 System without PV connection

### 3.5.3 System without battery

In this configuration, the battery unit(s) can be added later.

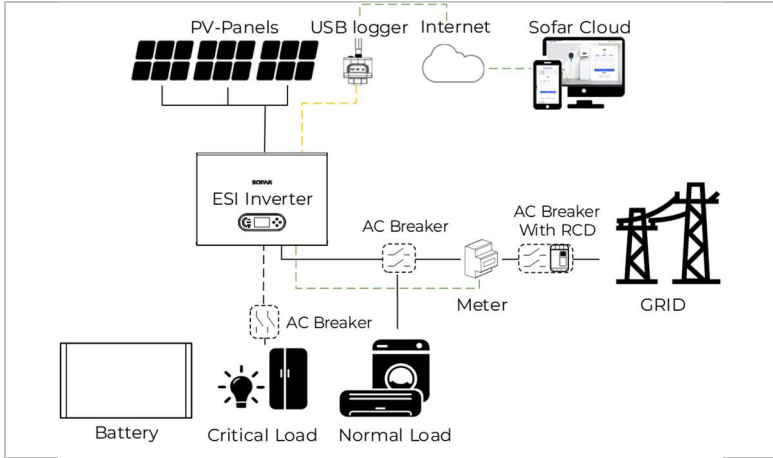

Figure 3-7 System without battery

### 3.5.4 Back-up mode (off-grid)

When there is no grid connection, the PV panels and the battery will provide electricity to the critical load.

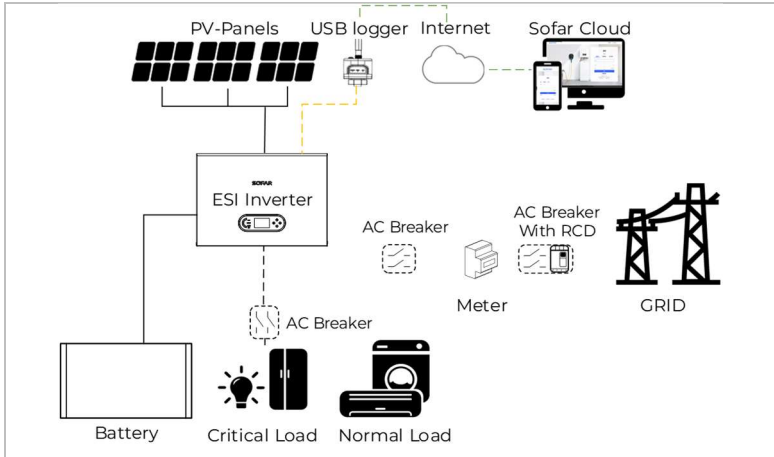

Figure 3-8 Back-up mode (Off- Grid)

### 3.5.5 System with multiple inverters (5-72kVA)

In the on-grid mode, a maximum of 6 inverters can be connected in parallel. In the off-grid mode, a maximum of 3 inverters can be connected in parallel, resulting in BACKUP output of up to 36 kVA.

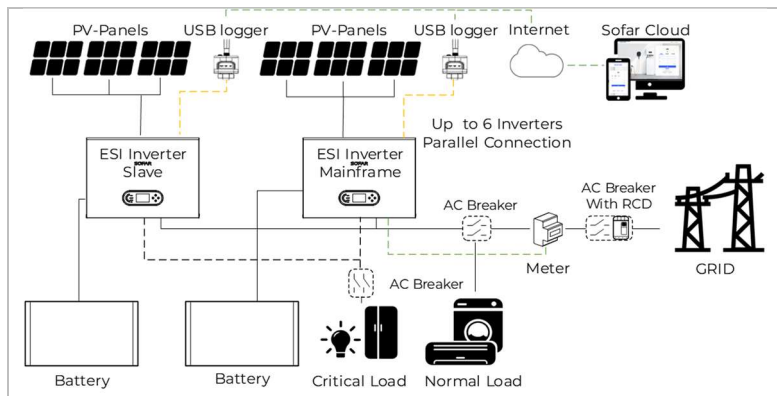

Figure 3-9 System with multiple inverter

- ▶ Multiple inverters connected in parallel shall be of the same power model with the same power and battery configuration.
- ▶ The energy meter are connected to the Master inverter. Control of all inverters takes place via the link cable.
- ▶ For the parallel switching of several devices, it is recommended to use a joint BACKUP break switch for the connected loads at the LOAD connection.
- ▶ For the parallel switching of several devices, it is recommended to use a joint BACKUP break switch for the connected loads at the GRID connection.
- ▶ In order to evenly distribute the loads among the inverters, the cable length between each output and the load must be the same.
- ▶ If the maximum apparent power of a load is greater than 110% of the inverter' s rated output, the device must not be connected via the BACKUP terminal, but rather directly to the grid.

### 3.5.6 AC retrofit system

In this system configuration, the hybrid system for an already existing PV system is supplemented with a solar inverter of any brand. By installing a second smart meter, the PV production can be taken into account and used for charging the battery.

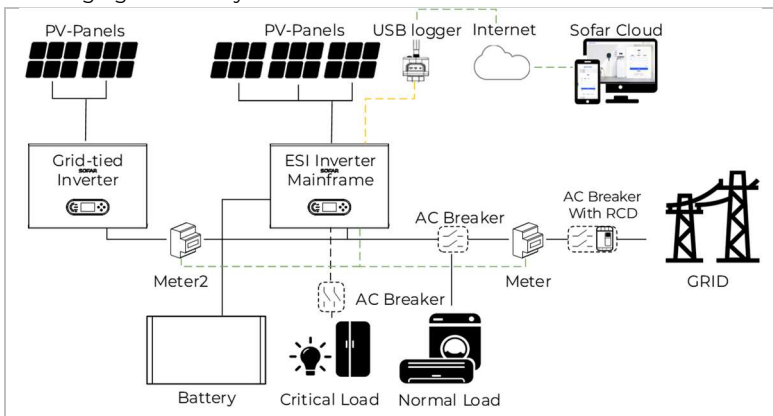

Figure 3-10 AC retrofit system

- ▶ The communication address of the PCC meter should be set to 1. Similarly, the communication address of the PV inverter meter 2...4 should be set to 2...4.

### 3.5.7 Unbalanced load

By enabling the “Unbalanced load” option, the inverter compensates unbalanced loads either in BACKUP mode.

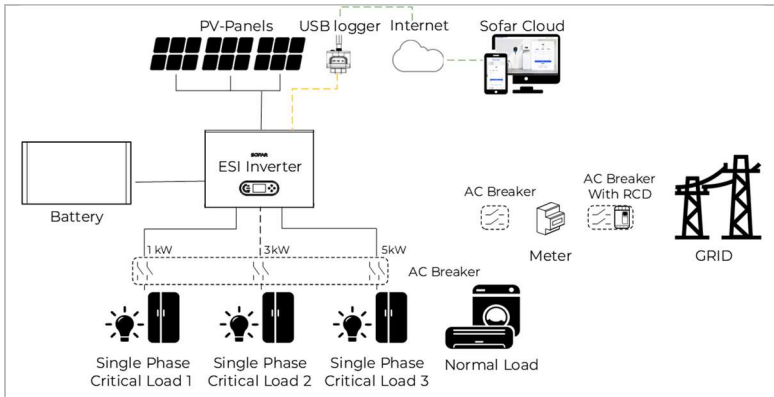

Figure 3-11 Unbalanced load (BACKUP Mode)

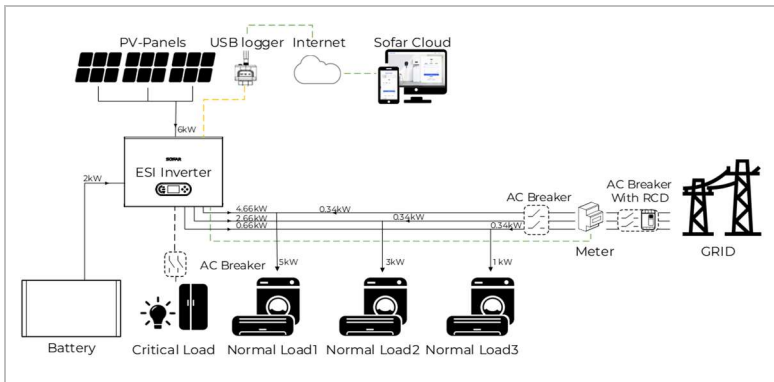



Figure 3-12 Unbalanced load (On Grid)

## 4 Installation

### 4.1 Installation information

 <b>DANGER</b>
<p><b>Fire hazard</b></p> <ul style="list-style-type: none"><li>▶ Do NOT install the inverter on flammable material.</li><li>▶ Do NOT install the inverter in an area in which flammable or explosive material is stored.</li></ul>

 <b>CAUTION</b>
<p><b>Burning hazard</b></p> <ul style="list-style-type: none"><li>▶ Do NOT install the inverter in places where it can be accidentally touched. The housing and heat sink may become very hot while the inverter is being operated.</li></ul>

<b>NOTICE</b>
<p><b>Weight of the device</b></p> <ul style="list-style-type: none"><li>▶ Take into account the weight of the inverter when transporting and moving it.</li><li>▶ Choose a suitable installation location and surface.</li><li>▶ Commission a minimum of two persons for the installation of the inverter.</li></ul>









### 4.2 Installation procedure

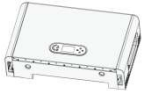
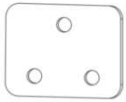









Mechanical installation is performed as follows:

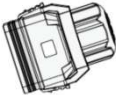
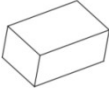

1. Examine the inverter before installation
2. Selection of mounting location and mounting method
3. Transport the inverter
4. Install the inverter

### 4.3 Examination before installation

After unpacking the inverter, check that the delivery items are both intact and complete. In the event of any damage or missing components, contact the wholesaler.

NO.	Image	Description	Quantity PCS
01		Inverter ESI-5...12K-T1	1
02		Connection plate	2
03		Retainer plate(left)	1
04		Retainer plate(right)	1
05		PV+ input terminal	3
06		PV- input terminal	3
07		MC4 connector contact PV+	3
08		MC4 connector contact PV-	3
09		M6*60 expansion screws	4

NO.	Image	Description	Quantity PCS
10		M4*12 screws	6
11		M6*14 screws	4
12		BAT- connector contact	1
13		COM connector cable end	1
14		USB acquisition stick	1
15		Decorative cover with screw (left side)	1
16		Decorative cover with screw (right side)	1
17		Three-phase smart meter	1
18		Base decorative cover	2
19		Quick installation guide	1
20		Outgoing inspection report	1
21		Matching resistance	1

NO.	Image	Description	Quantity PCS
22		GRID wire end female connector	1
23		LOAD wire end male connector	1
24		Base	1

### 4.3.1 Checking the external packaging materials

Packaging materials and components may become damaged during transportation. Therefore, the external packaging materials must be examined before the inverter is installed. Check the external packaging material for damage, e.g. holes and cracks. If you discover any damage, do not unpack the inverter and contact the transport company and/or dealer immediately. It is recommended that the packaging material should be removed within 24 hours before installing the inverter.

### 4.3.2 Checking the delivery scope

After unpacking the inverter, check that the delivery items are both intact and complete. In the event of any damage or missing components, contact the wholesaler.

### 4.4 Connections

**⚠ CAUTION**

**Damage during transportation**

- ▶ Please check the product packaging and connections carefully prior to installation.

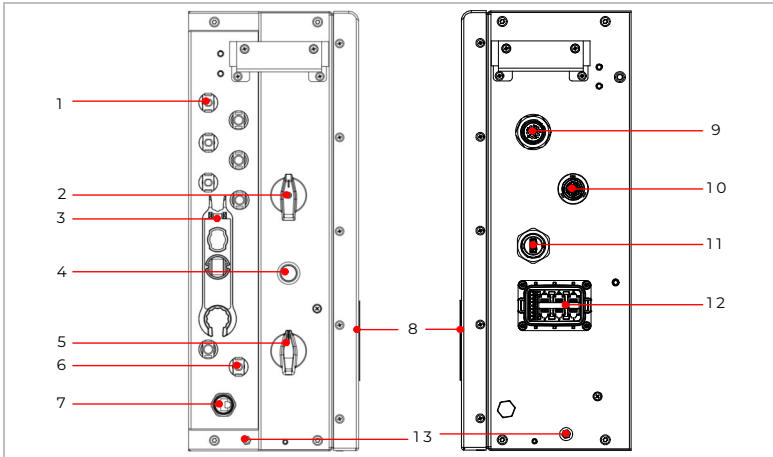



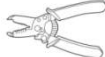





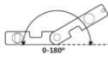
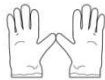

Figure 4-1 ESI-5...12K-T1 inverter overview

1	PV input terminals	8	LCD display
2	PV switch	9	AC grid connection
3	Terminal remover	10	AC backup connection
4	Battery power button	11	Wi-Fi /4G
5	BAT switch	12	Communication connection
6	BAT input terminals	13	PE port
7	BAT communication port		

### 4.5 Tools

Prepare the tools required for the installation and the electrical connection.

No.	Tool	Model	Function
01		Hammer drill Recommended drill diameter: 8mm	Used to drill holes in the wall.
02		Screwdriver	Wiring
03		Phillips screwdriver	Used to remove and install the screws of the AC terminal
04		Removal tool	Used to remove the PV , battery terminal
05		Wire stripper	Used to strip the wire
06		6mm Allen key	Used to turn the screw to connect the rear panel to the inverter
07		Crimping tool	Used to crimp power cables
08		Multimeter	Used to check the earthing
09		Marker	Used for marking
10		Measuring tape	Used to measure distances
11		Spirit level	Used to align the wall bracket
12		ESD gloves	for the installer

13		Safety goggles	for the installer
14		Anti-dust respiratory mask	for the installer

### 4.6 Installation Environment Requirements

- ▶ Choose a dry, clean, and tidy place, convenient for installation.
- ▶ Operating temperature range: -30 to +60°C(derating above +45°C).
- ▶ Relative humidity: 5...95% (non-condensed).
- ▶ The inverter shall be installed in a well-ventilated place.
- ▶ Do not place the inverter close to flammable or explosive materials.
- ▶ The AC overvoltage category of the inverter is category III.
- ▶ Maximum altitude: 4000m(derating above 2000 m)

### 4.7 Installation location

Choose a suitable location to mount the inverter (stacking three batteries for example). Ensure that the following requirements are met:

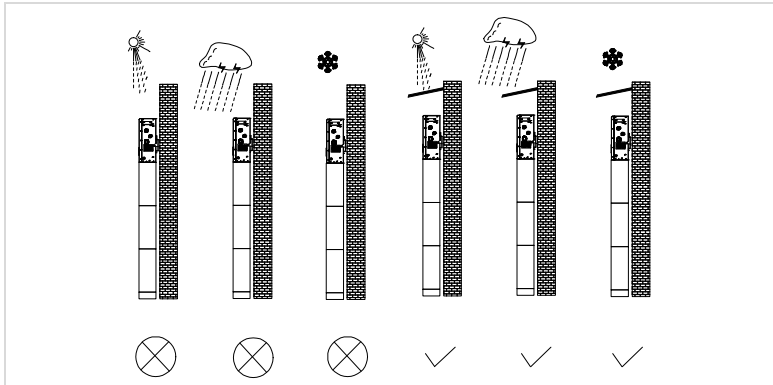

Figure 4-2 Installation Position of ESI-5...12K-T1

Minimum distances for individual ESI-5...12K-T1 inverters: 30 cm

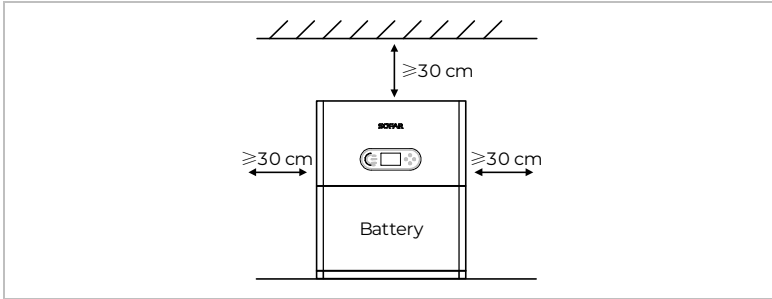

Figure 4-3 Minimum distances for individual inverter

Minimum distances for several ESI-5...12K-T1 inverters:

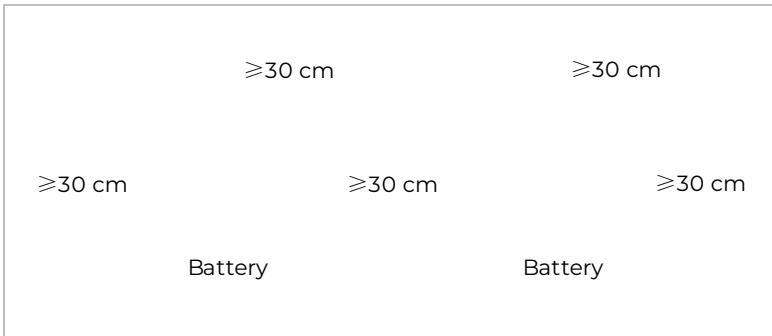

Figure 4-4 Minimum distances for several inverter

## 4.8 Unpacking the inverter

1. Open the package and hold the handles above the inverter on both sides with both hands.

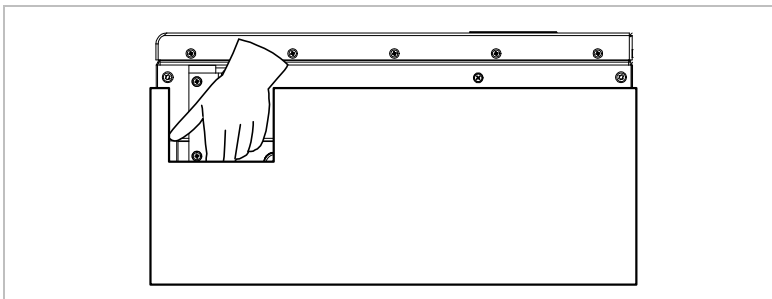



Figure 4-5 Moving the inverter

2. Lift the inverter out of the packaging and move it to its installation position.

<b>NOTICE</b>
<p><b>Mechanical damage</b></p> <ul style="list-style-type: none"> <li>▶ In order to prevent injuries and damage to the device, ensure that the inverter is kept balanced while it is being moved - it is very heavy.</li> <li>▶ Do not place the inverter on its connections, as these are not designed to bear its weight. Place the inverter horizontally on the ground.</li> <li>▶ When you place the inverter on the ground, place foamed material or paper underneath it in order to protect its housing.</li> </ul>

## 4.9 Safety instructions

This topic describes the electrical connections of the inverter ESI-5...12K-TI. Read this section thoroughly and carefully before connecting the cables.

 <b>DANGER</b>
<p><b>Electrical voltage at the DC connections</b></p> <ul style="list-style-type: none"> <li>▶ Ensure that the DC switch is OFF before establishing the electrical connection. The reason is that the electrical charge remains in the capacitor after the DC switch has been switched off. Therefore, at least 15 minutes must lapse before the capacitor has been electrically discharged.</li> </ul>

 <b>DANGER</b>
<p><b>Electrical voltage</b></p> <ul style="list-style-type: none"> <li>▶ PV modules generate electrical energy when exposed to sunlight, and this may present an electrical shock hazard. Therefore, cover the PV modules with an opaque sheet before connecting to the DC input power cable.</li> </ul>

**⚠ DANGER****Electrical voltage at the DC connections**

- ▶ Wear rubber gloves and protective clothing (safety goggles and boots) when working on high voltage/high current systems such as inverter and battery systems.

**NOTICE****Qualification**

- ▶ The installation and maintenance of the inverter must be carried out by an electrician.
- ▶ Consumers must not remove the BACKUP plug from the inverter.

**NOTICE****On-grid operation**

- ▶ After connecting the external terminals of the inverter, the recommended power-up sequence is: first turn on the battery switch, then turn on PV switch, then press the battery power button, until you hear the battery turn on, then connect to the grid, and finally connect the load.
- ▶ After connecting the external terminals of the inverter, the recommended de-energizing sequence is: first disconnect the load, then disconnect the grid, then disconnect PV switch, then disconnect the battery switch, and finally press the battery power button, until you hear the battery shut down.

- ▶ The open-circuit voltage of the modules connected in series must be lower than or equal to 1000V.
- ▶ The connected PV modules must be compliant with IEC 61730 class.

The DVC (decisive voltage classification) is the circuit voltage which constantly occurs between two arbitrary live parts during proper use in a worst-case scenario:

Table 4-1 Description of limits for DVC

DVC	Operating voltage limit(V)		
	Ac voltage (RMS)	Ac voltage (PK)	Dc voltage (AVG)
A	25 (16)	35.4 (22.6)	60 (35)
B	50 (33)	71 (46.7)	120 (70)
C	1000	4500	1500

► The values in brackets apply when the inverter is installed in a humid environment.

Table 4-2 The decisive voltage class (DVC)

Interface	DVC
PV input connection	DVCC
GRID connection	DVCC
BAT connection	DVCC
BACKUP connection	DVCC
WiFi/4G interface	DVCA
COM interface	DVCA

### 4.10 Wiring overview

Table 4-3 Cable description

Component	Description	Recommended cable type	
	BAT+ : Connect the positive cable of the lithium battery	Outdoor multicore copper cable (4...6mm <sup>2</sup> )	
	BAT- : Connect the negative cable of the lithium battery		
	PV+ : Connect the positive cable of the PV array	PV cable (4...6mm <sup>2</sup> )	
	PV- : Connect the negative cable of the PV array		
<p>Backup</p>	Connection method: male and female terminals are inserted into each other.	L1	Outdoor multicore copper cable 6...10mm <sup>2</sup>
		L2	
		L3	
		N	
		PE	
<p>Grid</p>	Connection method: male and female terminals are inserted into each other.	L1	Outdoor multicore copper cable 6...10mm <sup>2</sup>
		L2	
		L3	
		N	
		PE	

► The selection of the cable cross-section must take into account the length of the cable used and the circuit breaker according to the national standard.

### 4.11 System Electrical Topology

The inverters GRID and BACKUP are wired with different N and PE wires depending on the regulatory requirements in different regions. For users in Australia, South Africa and New Zealand, please use the System Electrical Topology in System2.

#### System 1: Internal relay controls N-PE grounding

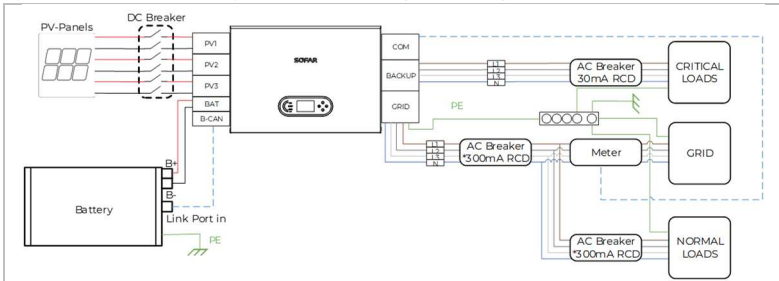

Figure 4-6 System Electrical Topology (a)

- ▶ Ensure that both the BACKUP and GRID PE wires are grounded at the same time, as shown in the diagram. Otherwise, the inverter may be abnormal in off-grid mode.
- ▶ In system 2, Neutral Point Grounding is disabled by default. Check whether Neutral Point Grounding is enabled, if not, enable it manually: Advanced Setting -> Input 0715 -> NeutralPointGrounding->Enable

#### System 2: N and PE wires are connected together

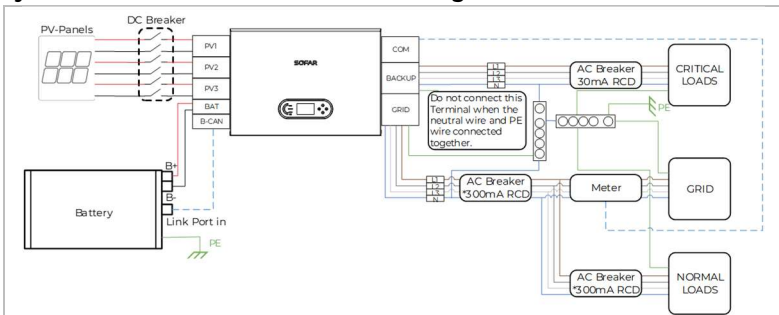

Figure 4-7 System Electrical Topology (b)

 **DANGER****Install Residual current device (RCD) in front of the load**

- ▶ RCD is necessary for critical load, but optional for normal load.
- ▶ In off-grid mode, the BACKUP switch is unprotected and load leakage could lead to shock danger.
- ▶ The Entry master switch installed in the house must have earth leakage protection and its rated earth leakage action current > number of inverters \* 100mA(suggestive value).

 **DANGER****Be sure to ensure that the output is grounded**

- ▶ In system 1, the PE line of the inverter's GRID Port and BACKUP Port must be grounded through the PE-Bar, otherwise there may be a risk of leakage.
- ▶ According to the **Australian safety regulations**, the neutral cables on the grid-connected side and BACKUP side must be connected together. Otherwise, the BACKUP cannot be used.

## 4.12 Smart Meter / CT

There are different system configurations possible depending on the user's requirements, existing electrical infrastructure and local regulations. The distribution box must be configured to comply to the grid operator requirements.

The inverter has an integrated AC relay to disconnect all phases and Neutral from the grid in case of grid fault or grid outage.

The inverter's power generation and feed-in limiting functions require the use of an external direct-connected meter to obtain grid information.

There are 3 system configurations:

- ▶ System A: measurement of energy with directly connected smart meter – Default configuration(default)
- ▶ System B: direct measurement of energy with CT's (3000:1)

- ▶ The secondary side current of Scheme B is less than 100mA. The length of the lead of CT cannot exceed 1 km(too long will result in poor accuracy).

### CAUTION

In the following three situations, the system must be connected to the fuse first and then to the machine's input terminal:

Lead-acid battery

Lithium battery without BMS

Multiple lithium batteries connected to one input

### 4.12.1 System A: measurement with directly connected energy meter (default)

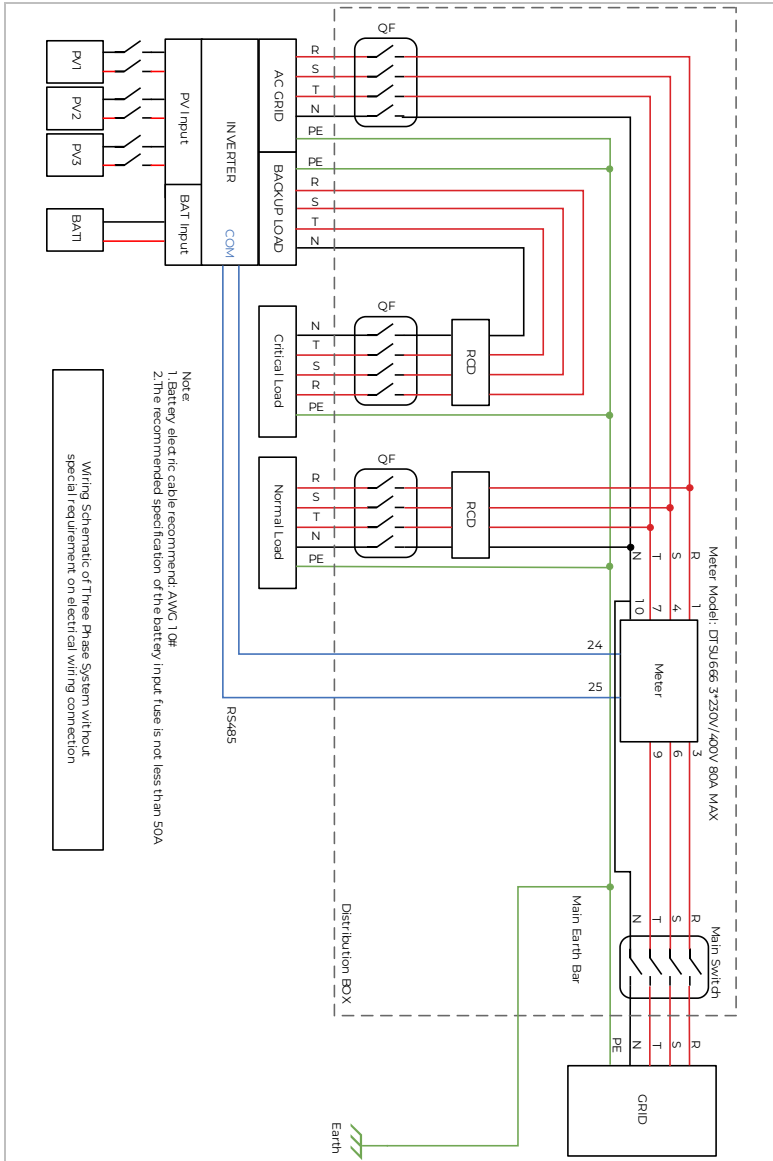

Figure 4-8 Electrical connections (Plan A: Meter)

4.12.2 System B: direct measurement of energy with CTs

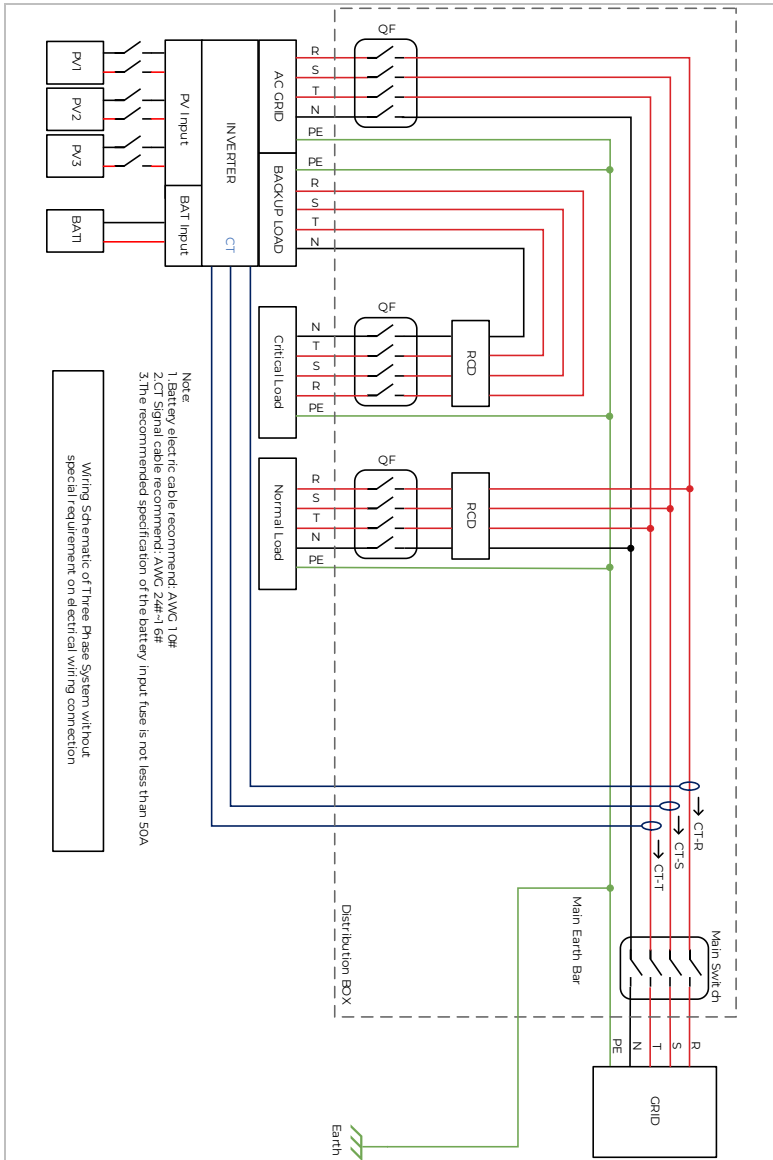

Figure 4-9 Electrical connections (Plan B: CTs)

**Directly connected Energy Meter:**

Table 4-4 Directly connected Smart Meter

Technical Data	
Nominal voltage	230 V AC/400 V AC, 50 Hz/60 Hz
Current measurement range	Direct connection: 0–80 A Connection through current transformers: > 80 A
Voltage measurement range	90–1000 V (line voltage; potential transformers are required if the voltage is greater than 500 V)
Electricity metering accuracy	Class 1 (error within $\pm 1\%$ )
Power grid system	Active Class 1, Reactive Class 2
Baud rate	1200/2400/4800/9600/19200/115200 bps (default value: 9600 bps)
Operating temperature	–25°C to +60°C
Installation mode	Guide rail-mounted

### 4.13 Electrical connection

The electrical connection is established as follows:

1. Connect PE cable
2. Connect DC input cable
3. Connect battery cable
4. Connect AC output power cable
5. Connect communication cable (optional)

## 4.14 Connecting the PE cables

Connect the inverter to the equipotential bonding bar by using the protective earth cable (PE) for grounding.

### NOTICE

#### Pole earthing not permissible!

- ▶ As the inverter is transformerless, the plus and minus poles of the PV generator must NOT be earthed. Otherwise, the inverter will malfunction. In the PV system, not all live metal parts (e.g. PV module frames, PV frame, generator connection box housing, inverter housing) require earthing.
- ▶ The protective grounding of the chassis shell cannot replace the PGND cable of the BACKUP Port. Ensure that the two PGND cables are reliably connected.
- ▶ When multiple inverters are deployed, ensure that the protection ground points of all inverters are equipotential connected.

1. Remove the insulation of the cable. For outside use, the PE cable recommended for use in EU depends on the protection breakers used and the length of cable, it is recommended to use:  $4\text{mm}^2 \leq \text{PE cable} \leq 10\text{mm}^2$ .

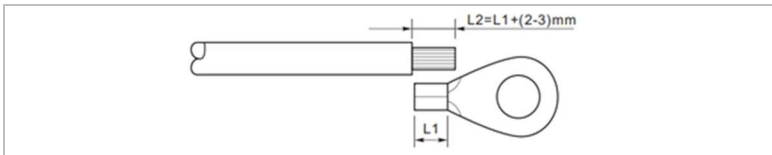

Figure 4-10 Connecting PGND cable(a)

- ▶ L2 is 2 to 3 mm longer than L1.

2. Crimp the cable to the ring terminal:

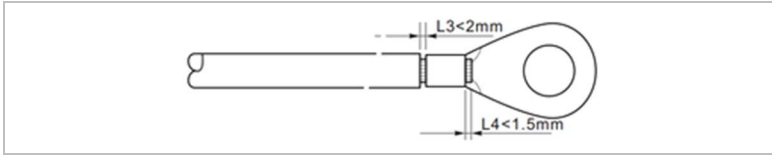

Figure 4-11 Connecting PGND cable(b)

### 4.15 Connecting the DC lines for the PV modules and battery

► The connection steps of the battery and PV are the same, only the terminal specifications are different. The colour of the battery terminal is blue, the colour of PV terminal is black.

Please observe the recommended cable dimensions:

Cable cross-section (mm <sup>2</sup> )		Outer diameter of cable (mm)
Range	Recommended value	
4.0 ... 6.0	4.0	4.5 ... 7.8

1. Remove the crimp contacts from the positive and negative connections.
2. Remove the insulation of the cables:

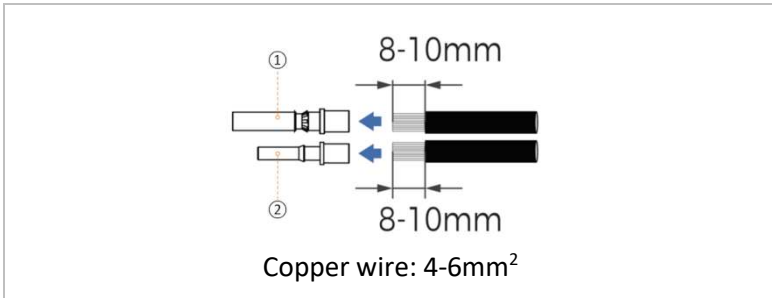

Figure 4-12 Connecting PV(a)

- ① Positive DC cable                      ② Negative DC cable

► L2 is 2 to 3 mm longer than L1

3. Insert the positive and negative DC cables into the corresponding cable glands.

4. Crimp the DC cables. The crimped cable must be able to withstand a tractive force of 400 Nm.

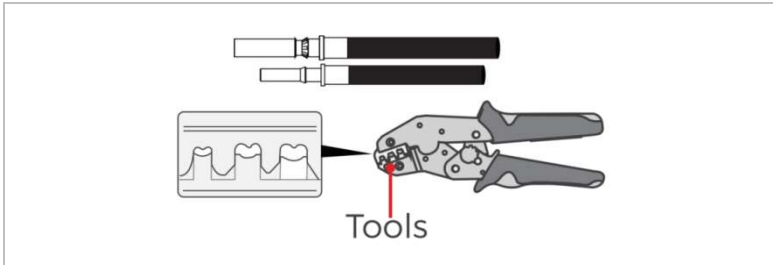

Figure 4-13 Connecting PV(b)

**⚠ CAUTION**

**Danger of reverse polarity!**

- ▶ Ensure that the polarity is correct before plugging into the DC connections!

5. Insert the crimped DC cables into the corresponding connector housing until you hear a “clicking” sound.

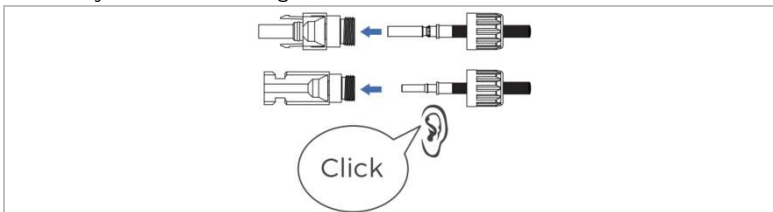

Figure 4-14 Connecting PV(c)

6. Re-screw the cable glands to the connector housing.

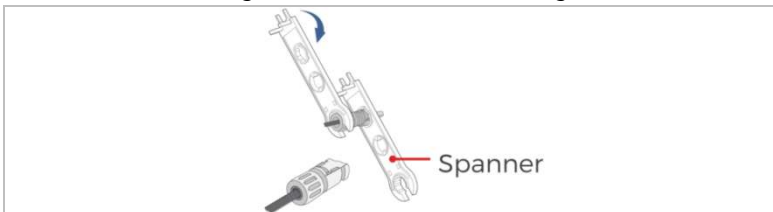

Figure 4-15 Connecting PV(d)

7. Use a multimeter to measure the voltage at both ends of the positive and negative terminals to ensure that the terminals are connected reliably.

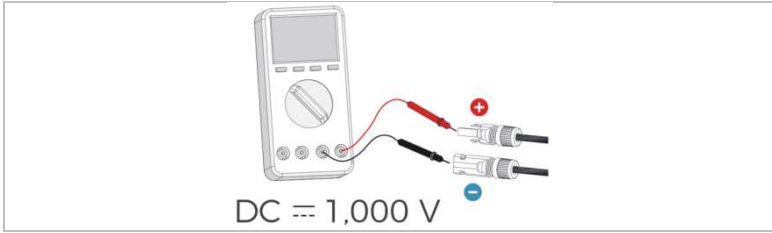

Figure 4-16 Testing PV(e)

8. Insert the positive and negative connectors into the corresponding DC input terminals of the inverter until you hear a “clicking” sound.

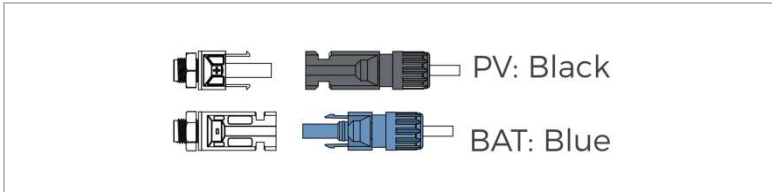

Figure 4-17 Connecting PV(f)

- ▶ Insert the protective caps into the unused DC connections.

**⚠ CAUTION**

**Danger of DC arcing**

- ▶ Before removing the plus and minus connector, ensure that the DC switch has been set to OFF.

In order to remove the plus and minus connection from the inverter, insert a removal key into the locking and press on the key with the adequate force as shown in the following illustration:

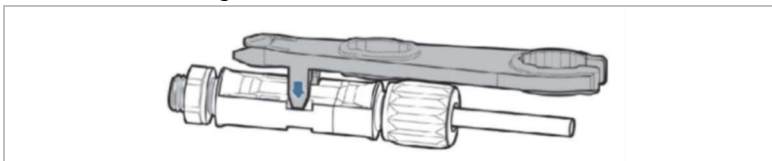

Figure 4-18 Connecting PV

### 4.16 Connecting the AC power cables

The AC power cables are used to connect the inverter to the critical loads (through the BACKUP port), and the AC power distributor or the power grid.

**⚠ CAUTION**

**AC connection**

- ▶ Each inverter must have its own circuit breaker.
- ▶ The AC disconnecting device must be easily accessible.

- ▶ The inverter ESI-5...12K-T1 has a built-in AFI (univ. sensitive residual current protection). If an external AFI is required, we recommend an AFI type A featuring a residual current of 100 mA(suggestive value) or higher.
- ▶ Please follow the national rules and regulations for the installation of external relais or circuit breakers!

The AC cable should be correctly dimensioned in order to ensure that the loss of power in the AC cable is less than 1% of the rated output. If the AC cable resistance is too high, then the AC voltage will increase; this may cause the inverter to become disconnected from the power grid. The relationship between the leakage power in the AC cable and the cable length, the cable cross-section, is displayed in the following illustration:

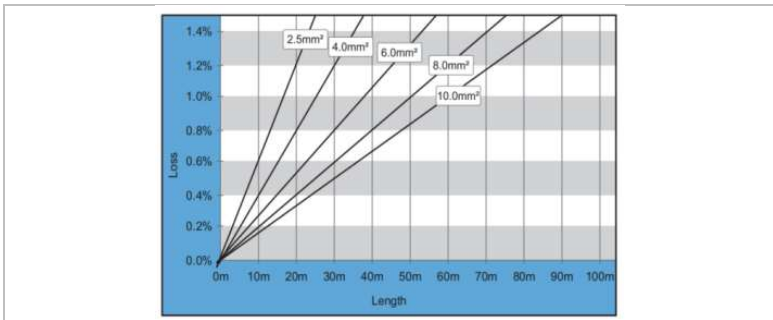

Figure 4-19 The relationship between the leakage power and cable length

### 4.17 AC connector installation

<b>⚠ CAUTION</b>
<p><b>Electrical voltage</b></p> <ul style="list-style-type: none"> <li>▶ Ensure that the grid has been switched off before removing the AC connector</li> </ul>

Please follow below steps to install the AC connector.

1. Select the suitable cable in accordance with above diagram. Remove the insulating layer of the AC output cable using a wire stripper and in accordance with the following illustration:

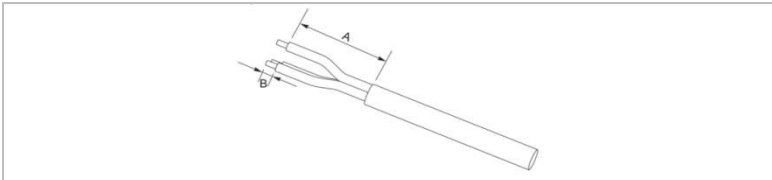

Figure 4-20 AC connection (a)

A	30~50 mm	B	3~5 mm
---	----------	---	--------

2. Disassemble the connector in accordance with the following illustration. Guide the AC output cable through the cable gland.

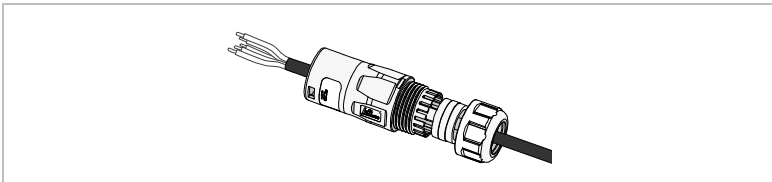

Figure 4-21 AC connection (b)

3. Connect the AC cable in accordance with the following requirements and tighten the terminal using the Allen key.

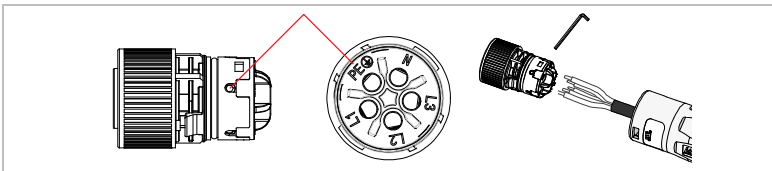

Figure 4-22 AC connection (c)

Connection	Cable
L1	Phase 1 (brown)
L2	Phase 2 (black)
L3	Phase 3 (grey)
N	Neutral conductor (blue)
PE	Earthing cable (yellow-green)

4. Plug the connector into the port and end when you hear a click.

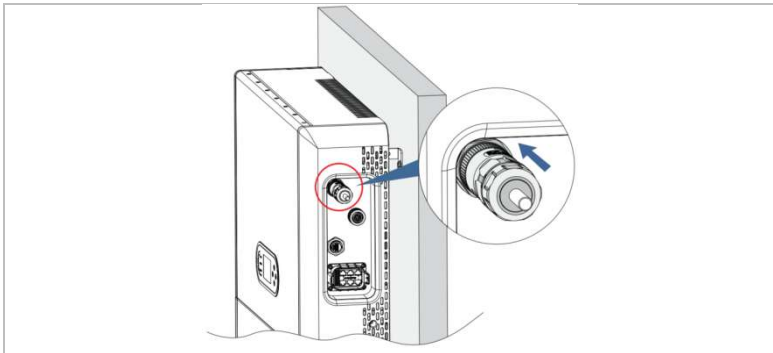

Figure 4-23 AC connection (d)

- ▶ Use the removal tool to unlock and then rotate counterclockwise to remove the connector.
- ▶ When you use the meter connection function, make sure that the AC terminal cable corresponds to the meter cable one by one (L1, L2, L3, N, and PE cables)
- ▶ Corresponding to the grid identification of different regions, L1, L2, L3 correspond to A, B, C or R, S, T or U, V, W respectively.

### 4.18 Communication interfaces

The positions of the communications interfaces of the ESI-5...12K-T1 are displayed below:

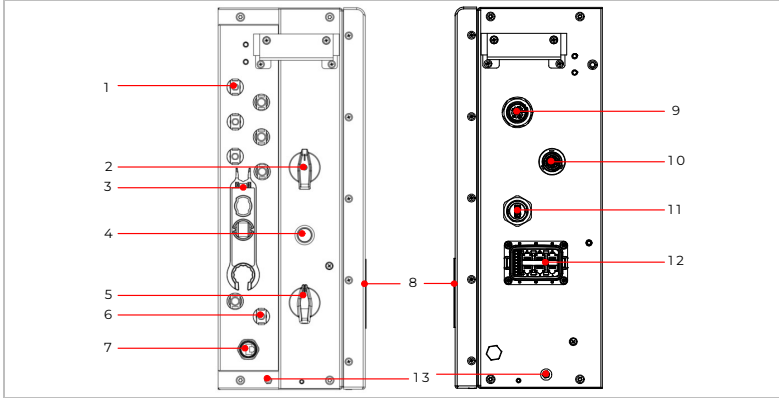

Figure 4-24 ESI-5...12K-T1 interfaces

No.	Connection	Function
7	BAT communication port	Connect the battery to read battery information or assist with battery software upgrades.
11	Wi-Fi/4G	USB port for firmware upgrade and safety parameter import; Port to connect Stick Logger (Wi-Fi).
12	Communication connection	Multi-functional communication ports including parallel, Ethernet, Meter/CT, DRMS, charging pile, dry contact, etc.

### 4.18.1 Multifunctional Communication Port Definition

Please refer to the following table for the specific PIN assignments.

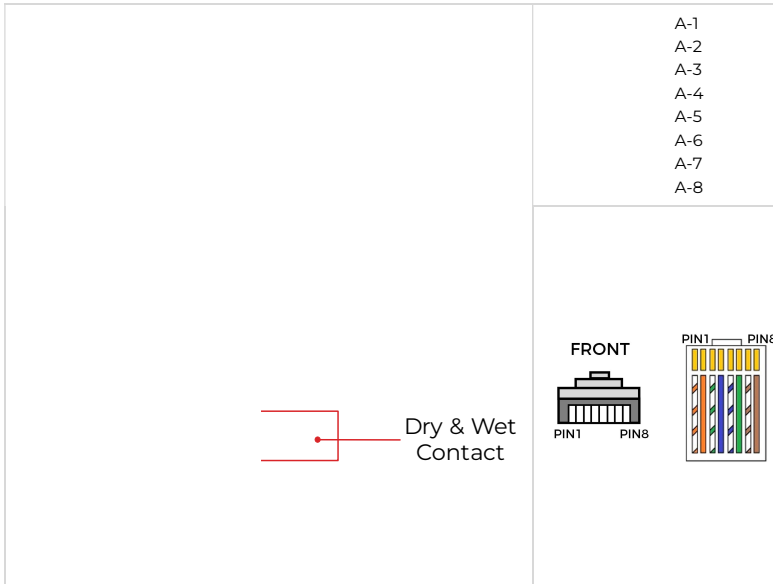

Figure 4-25 COM interfaces

Wall Box			
PIN	Colour	Connection	Function
1	Orange White	Wallbox- RS485 A	Wallbox-RS485 differential signal+
2	Orange	Wallbox- RS485 B	Wallbox-RS485 differential signal-

<b>Meter/CT</b>			
<b>PIN</b>	<b>Colour</b>	<b>Connection</b>	<b>Function</b>
1	Orange White	Meter-RS485 A	Meter-RS485 differential signal+
2	Orange	Meter-RS485 B	Meter-RS485 differential signal-
3	Green White	CT A+	CT A differential signal+
4	Blue	CT B+	CT B differential signal+
5	Blue White	CT B-	CT B differential signal-
6	Green	CT A-	CT A differential signal-
7	Brown White	CT C+	CT C differential signal+
8	Brown	CT C-	CT C differential signal-

<b>DRMs</b>			
<b>PIN</b>	<b>Colour</b>	<b>Connection</b>	<b>Function</b>
1	Orange White	DRM1/5	DRM1/5
2	Orange	DRM2/6	DRM2/6
3	Green White	DRM3/7	DRM3/7
4	Blue	DRM4/8	DRM4/8
5	Blue White	GND	GND
6	Green	DRM0	DRM0
7	Brown White	/	Internally shorted
8	Brown	/	

Dry & Wet Contact			
PIN	Ports	Connection	Function
1	A-1	DI IN	Dry contact input signal
2	A-2	DI GND	Dry contact ground signal
3	A-3	DO NO	Dry contact normal high signal
4	A-4	DO COM	Dry contact communication signals
5	A-5	WO1 NO	Wet contact normal high signal 1
6	A-6	WO1 GND	Wet contact ground signal 1
7	A-7	WO2 NO	Wet contact normal high signal 2
8	A-8	WO2 GND	Wet contact ground signal 2

- ▶ Link port for Ethernet: Ethernet.
- ▶ Link port for Parallel: link0 and link1.

### 4.18.2 Multifunctional Communication Cable Production

1. Prepare a RJ45 cable, according to the length of the connector appropriate to open one end of the cable :

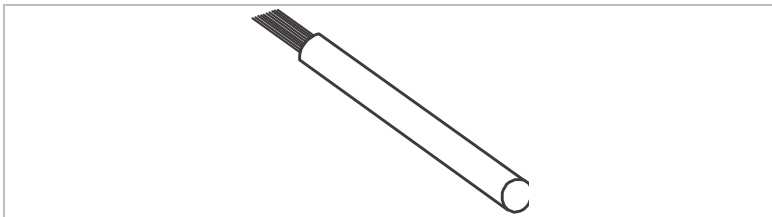

Figure 4-26 COM connector production (a)

2. Remove the rubber plugs from the COM connector and pull out the appropriate number of plugs according to the desired function:

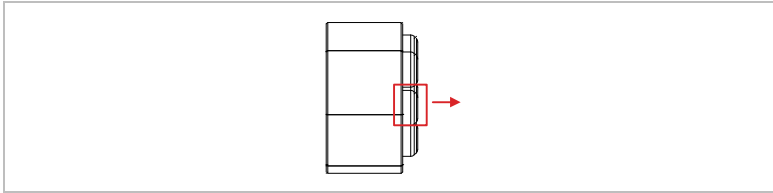

Figure 4-27 COM connector production (b)

3. After removing the stopper, pass the cable through the connector gland, connector clip and connector through-hole. Crimp the cable to the terminal connector in the colour shown below:

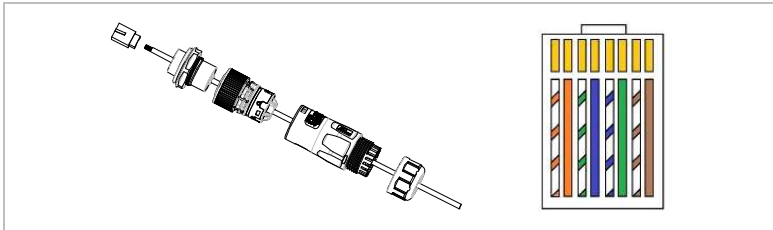

Figure 4-28 COM connector production (c)

4. After assembling the connectors in order, insert the RJ45 connector into the corresponding terminal of the COM port:

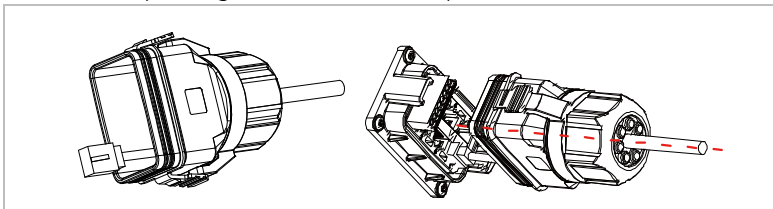

Figure 4-29 COM connector production (d)

5. Locking the connector housing to the inverter COM port:

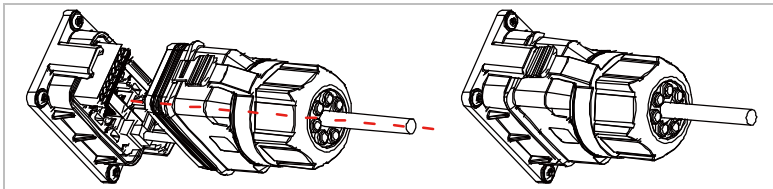

Figure 4-30 COM connector production (e)

### 4.18.3 Smart meter

The integrated energy management functions integrated of the ESI 5...12K-TI require to measure the power flow at the point of grid interconnection. There are different system configurations possible. It can be measured using directly connected smart meter or using smart meter with CTs.

The PIN assignment for the RS485 connection between inverter and smart meter can be found in the table below.

Inverter COM Port Pin	Function	Meter Pin
Meter/CT PIN1	Meter-RS485 A	Pin 24
Meter/CT PIN2	Meter-RS485 B	Pin 25

- ▶ The Smart meter shows a positive power value for feed-in to the grid, and a negative value for energy purchase from the grid.
- ▶ Use the shielded twisted pair cable.
- ▶ The copper outer diameter should be more than 0.5 mm<sup>2</sup>.
- ▶ Keep away from power cables or other electric fields.
- ▶ Use termination resistors at the ends of the RS485 line to improve signal quality

Connect the grid phases to the Smart Meter Pins according to below drawing for correct functionality of the inverter.

#### Smart meter with directly connection (System A, default configuration)

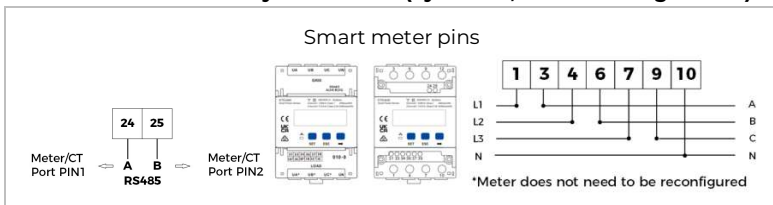

Figure 4-31 Directly Meter

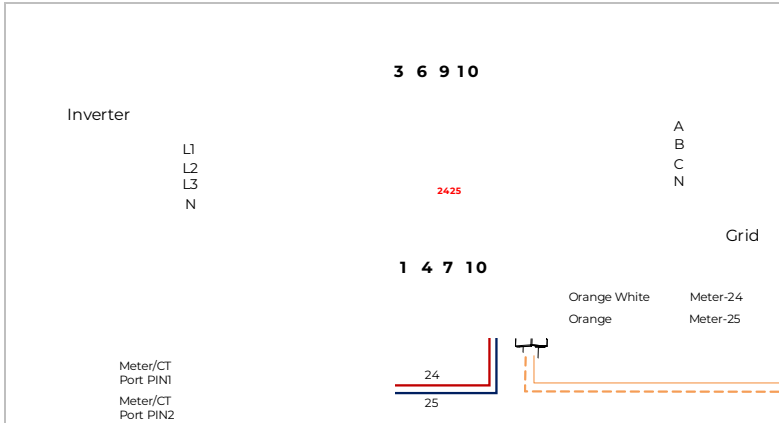

Figure 4-32 Directly Meter Electrical Connection

- ▶ No additional configuration required for direct-connected meters
  - ▶ Up to 80 A measurement
  - ▶ Accuracy class and load rating (VA/Ω):1 class
  - ▶ Rated operating voltage: 90 – 1000 V (line voltage; potential transformers are required if the voltage is greater than 500 V)
  - ▶ Rated frequency: 50~60Hz
  - ▶ Ambient temperature: -25°C~60°C
  - ▶ Altitude: ≤3000m
- 
- ▶ The inverter connected to the meter is a power generation device, and the function of the meter connected to the traditional load (electrical device) is opposite. Therefore, for our product, when the power is output to the grid, the electricity meter will show a positive value, and when the power is purchased from the grid, it will show a negative value.

**Smart Meter Configuration**

The smart meter is preconfigured to be used with the inverter with these settings:

- ▶ Modbus Address: 1
- ▶ Baud Rate: 9600
- ▶ Current Ratio: 60:1

In case you want to change or check the settings, please refer to below procedure:

**Modbus Address and Baud Rate setting**

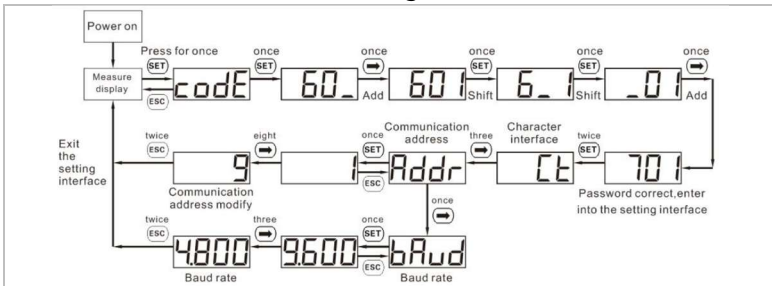

Figure 4-33 Meter address and baud rate setting

**Current Ratio setting**

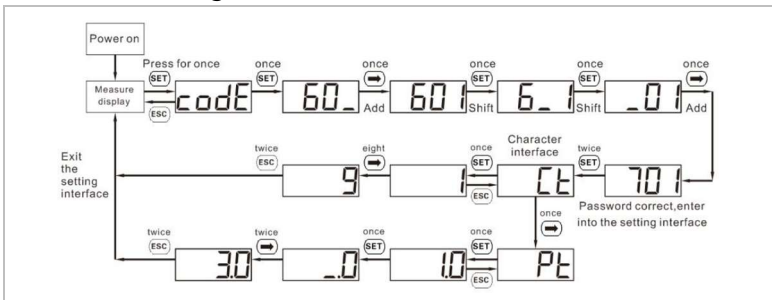

Figure 4-34 Meter current ratio setting

▶ The inverter connected to the meter is a power generation device, and the function of the meter connected to the traditional load (electrical device) is opposite. Therefore, for our product, when the power is output to the grid, the electricity meter will show a positive value, and when the power is purchased from the grid, it will show a negative value.

### 4.18.4 Parallel Port

In systems with multiple inverters, you can connect the devices in a Master/Slave configuration. In this configuration, only one energy meter is connected to the Master inverter for the system control.

- ▶ In the **off-grid mode**, a maximum of 3 inverters can be connected in parallel.
- ▶ In the **on-grid mode**, a maximum of 6 inverters can be connected in parallel.

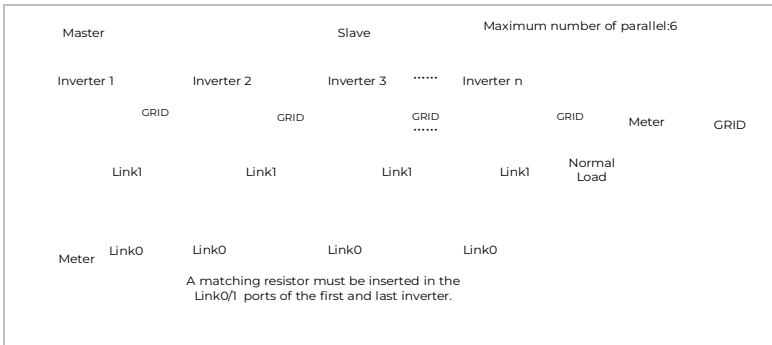

Figure 4-35 parallel system(on-grid mode)

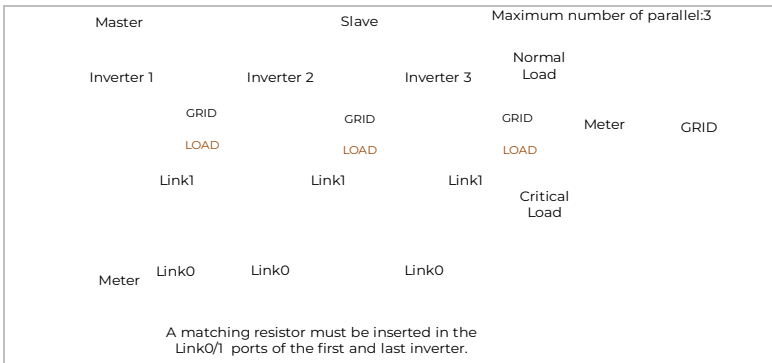
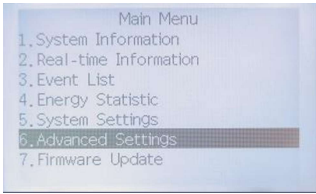
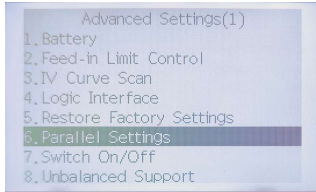

Figure 4-36 parallel system(off-grid mode)

**Parallel setting**



Select Advanced Settings



Select Parallel Settings



Enter the password 0715.

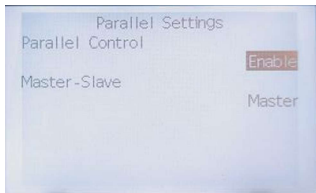

**Master inverter**

Select Inverter 1. Switch the parallel control from disabled to enabled. The default state of inverter 1 is that it is in the Master mode.



**Slave inverters**

Configure inverters 2 to n in sequence based on the number of parallel units. The maximum number of parallel units for three phase ESI inverter is six.

Setting parallel address from 2 to 6 for slave inverter.

- ▶ In the parallel operation mode, emergency power supply, generator mode and unbalanced support need to be turned off remotely first. The settings for the slave units must be made on the master machine after the remote shutdown.

- ▶ Be careful when the parallel inverters are connected, then the communication cable should not be bundled with the power cable (GRID - BACKUP) in one cable channel or to be very close, it may cause abnormal faults in the parallel system. it is preferable to pass the communications cables in a separate cable channel.

### 4.18.5 DRMs/Logic interface

The DRMs/Logic interface is used to control the inverters feed-in or purchases power by external signals, usually provided from grid operators with ripple control receivers or other means. The DRMO can be used for a switch off signal from external grid protection devices.

The logical interface pins are defined according to the requirements of different standards. Please connect according to the safety requirements of your country (see below for a brief description of the safety requirements).

First, connect the DRMs port cable in the COM port cable set to the control unit in accordance with the wire sequence required by the safety regulations:

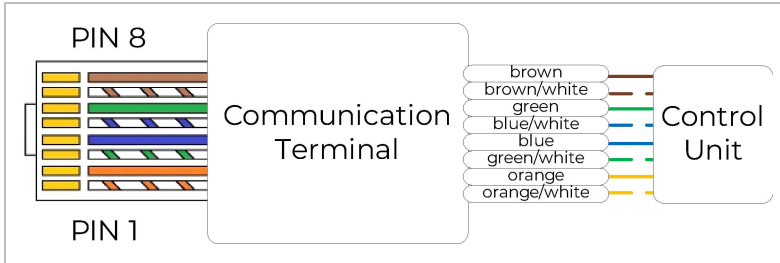

Figure 4-37 DRM connection(a)

Connect the RJ45 terminal on the other end of the COM connector to the DRMs port:

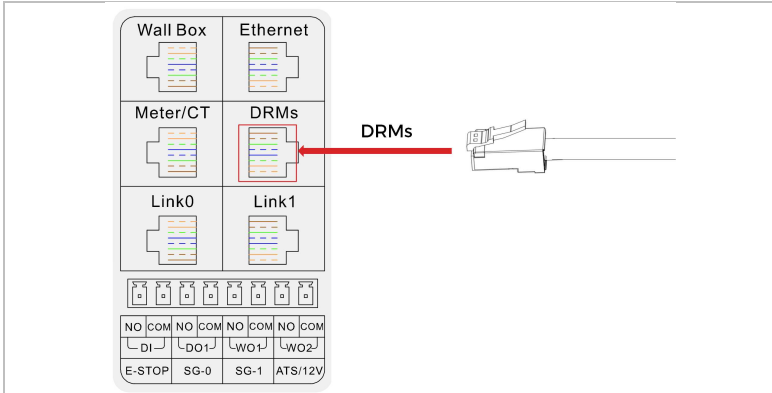

Figure 4-38 DRM connection(b)

**DRMs for AS/NZS 4777.2:2015 and AS/NZS 4777.2:2020**

Also known as Inverter Demand Response Modes (DRMs).

The inverter recognises all supported Demand Response commands and initiates the reaction within two seconds. The inverter will continue to respond while the mode remains asserted.

Pin	Colour	Function
1	orange/white	DRM1/5
2	orange	DRM2/6
3	green/white	DRM3/7
4	blue	DRM4/8
5	blue/white	RefGen
6	green	DRM0
7	brown/white	Internally shorted
8	brown	

Method of asserting demand response modes:

Mode	RJ45 socket Asserted by shorting pins:		Real current limit (referenced to inverter rated per phase current)
<b>DRM0</b>	5	6	0
<b>DRM1</b>	1	6	Import=0
<b>DRM2</b>	2	6	Import<50%
<b>DRM3</b>	3	6	Import<75%
<b>DRM4</b>	4	6	Not limited
<b>DRM5</b>	1	5	Generate=0
<b>DRM6</b>	2	5	Generate<50%
<b>DRM7</b>	3	5	Generate<75%
<b>DRM8</b>	4	5	Not limited

**Logic interface for VDE-AR-N 4105:2018-11**

This function serves to control and/or limit the output power of the inverter. The inverter can be connected to a radio ripple control receiver in order to dynamically limit the output power of all inverters within the system.

RCR: Ripple control receiver (RCR) is an interface between a PV system and power grid company.

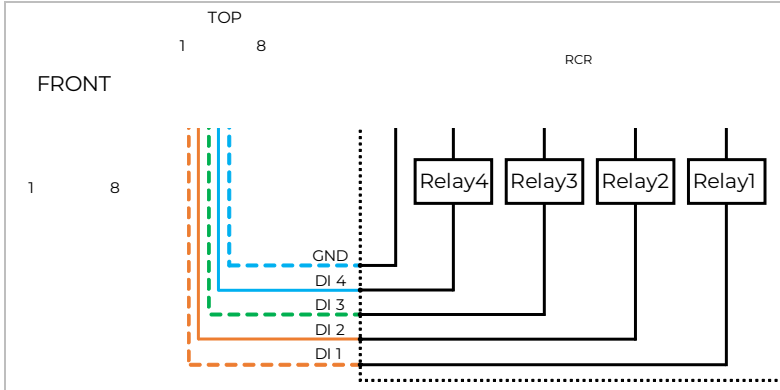

Figure 4-39 DRM connection(c)

The inverter is preconfigured on the following power levels:

Pin	Name	Parameter	Preset Power Value*
1	DI 1	Relay1 engaged	0%
2	DI 2	Relay2 engaged	30%
3	DI 3	Relay3 engaged	60%
4	DI 4	Relay4 engaged	100%
5	GND	Internal signal	

\*) When using this function on your own, make sure that the normally open relay is disconnected before use, and provide the drive signal for the relay on your own.

\*) Priority: DI 1> DI 2> DI 3> DI 4

**Logic interface for EN50549-1:2019**

The active power output can be ended within five seconds following a command to the input interface.

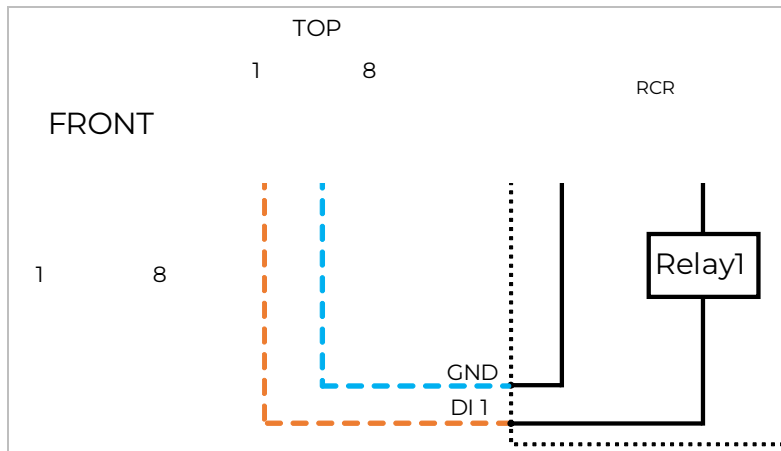

Figure 4-40 DRM connection(d)

**Functional description of the terminal**

Pin	Name	Inverter	Preset Power Value*
1	DI 1	Relay1 engaged	0%
5	GND	Internal signal	

### 4.19 Feed-in limitation function

The feed-in limitation function can be used to limit the power fed back into the grid. For this function, a power measurement device must be installed according to system A, B, or C.

**Feed-in limitation:** The sum of the feeding-in phases must not exceed the set power limitation value. The power of phases drawing power from the grid is disregarded here.

**3-phase limit:** The sum of the feed-in power of all three phases must not exceed the set power limit value. This setting is suitable for balancing metering, as is common in Germany, for example.

- ▶ For the 3-phase limit setting, the current sensors must be correctly assigned to phases L1, L2 and L3 on the electricity meter!
- ▶ If communication with the smart meter is interrupted, the inverter limits its output power to the set power limit value.

## 4.20 System monitoring

The ESI-5...12K-T1 inverters provide various communication methods for the system monitoring:

RS485 or WiFi stick (standard).

### 4.20.1 RS485

You can connect RS485-linked devices to your PC or a data logger via an RS485 USB adapter.

- ▶ The RS485 line may not be any longer than 1000 m
- ▶ Assign each inverter its own modbus address (1 to 31) via the LCD display

### 4.20.2 Wi-Fi/4G

When you have installed the stick logger, the inverters can directly upload your operating, energy and alarm data in the SolarCloud monitoring portal.

## 4.21 Installation of the WiFi

1. Remove the protective cap from the USB interface.
2. Install the WiFi stick.
3. Tighten the connecting nut.

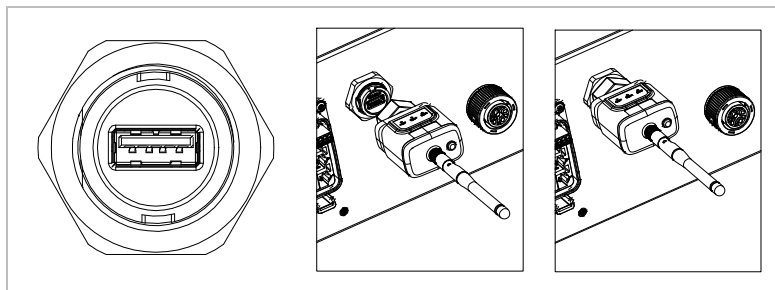

Figure 4-41 WiFi connection

### 4.21.1 Configuration of the WiFi stick via the web browser

**Preparation:** The WiFi stick is installed in accordance with the previous section and the SOFAR inverter must be in operation.

- ▶ WiFi network need to support 2.4 GHz mode. WiFi stick logger doesn't support 5 GHz network!
- ▶ The stick loggers are using outgoing TCP port 10000. In case your router has limited the ports please open it for the stick logger.

Carry out the following steps in order to configure the WiFi stick:

1. Connect your PC or smartphone with the WiFi network of the WiFi stick. The name of this WiFi network is "AP", followed by the serial number of the WiFi stick (see rating plate). When you are prompted for a password, you can find it on the label of the WiFi stick (PWD).
2. Open an Internet browser and enter the address **10.10.100.254**.
3. Enter the username and password, which are both set to **"admin"** by default. The "Status" page will be opened.
4. Click on the "Wizard" in order to configure the WiFi stick for Internet access.

Result: The WiFi stick begins to send data to SofarCloud.

If you has never registered an account in the management system, you can register it through the Installer Registration function. Registering the first installer user also enrolls a company.

**Step 1** Open a web browser, enter <https://eu.sofarcloud.com> in the address box, and press **Enter**. The login page is displayed.

**Step 2** Click **Register**. The **Registration** page is displayed.

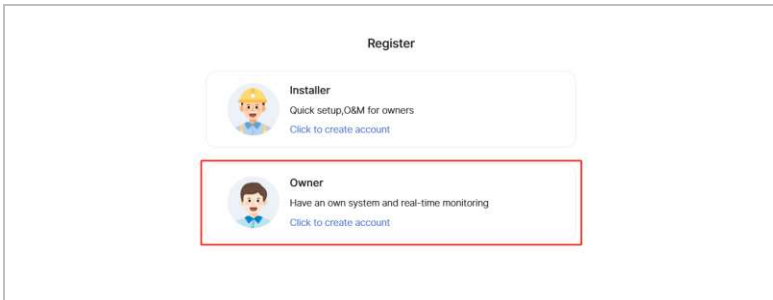
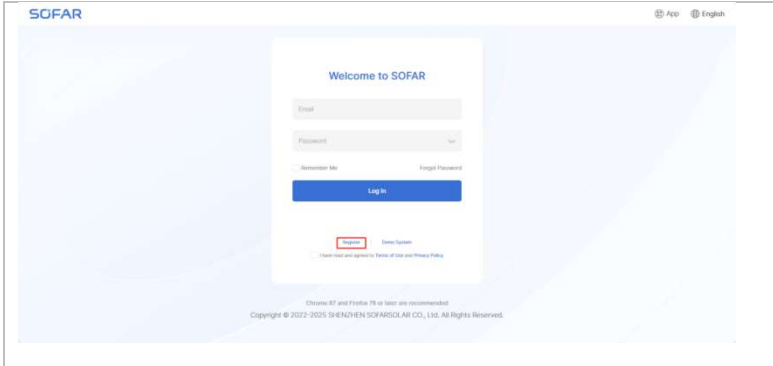

**Step 3** Sign up as an owner as prompted.

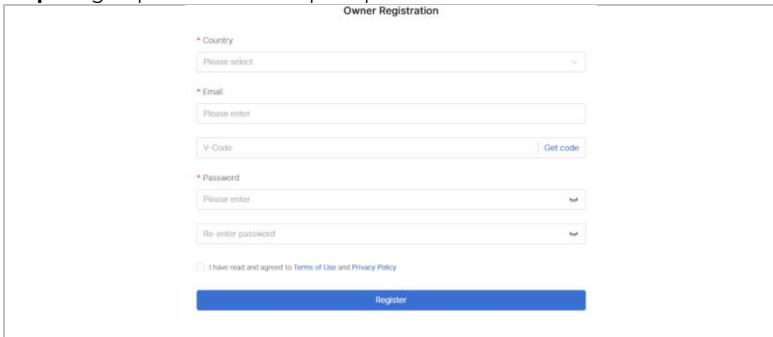

### 4.21.2 Setting up the WiFi stick with the app

To download the app, search for “SofarCloud” in the Apple or Google Play store, or use the following QR codes:

- ▶ **SofarCloud** (for end customers):



Scan the QR code on the inverter through the App or connect the inverter with Bluetooth to set the inverter data.

- ▶ If Bluetooth connection fails many times, please contact us.
- ▶ For additional App permissions like Firmware Upgrade or safety settings, please contact the local SOFAR service.

#### Configuration steps

1. After starting the app, register as a new user or enter the current SofarCloud access data.
2. Create a new system and save the system data.
3. Scan the barcode of the stick logger to assign an inverter to the system.
4. Go to the newly created system in order to configure the stick logger (device/logger)
5. Press the button on the WiFi stick for 1 second to activate the WPS mode of the stick so that the smartphone can be connected to the WiFi stick.
6. Now, select your local WiFi network for Internet access and enter your WiFi password.
7. The WiFi stick is configured with the access data.

### WiFi Logger Configuration Network

**Step 1** The phone connects to the wifi, but it should be noted that the wifi needs to be the same as the wifi that the logger is connected to.

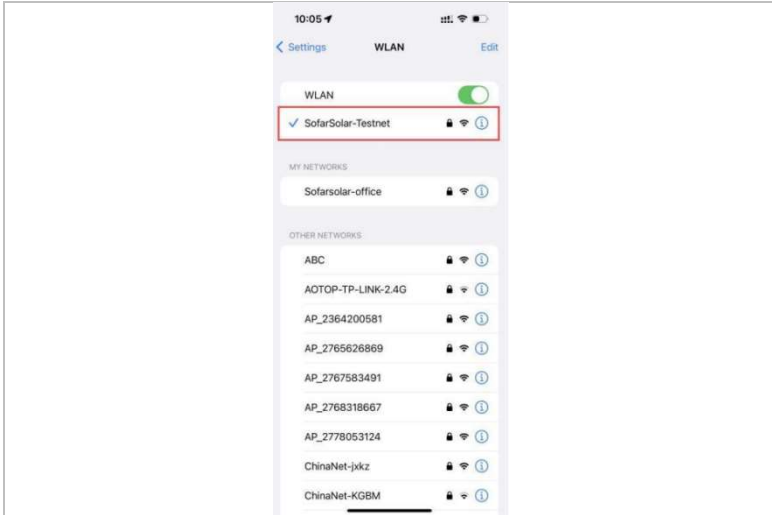

**Step 2** Open SofarCloud, go to “maintenance” and click “Scan”

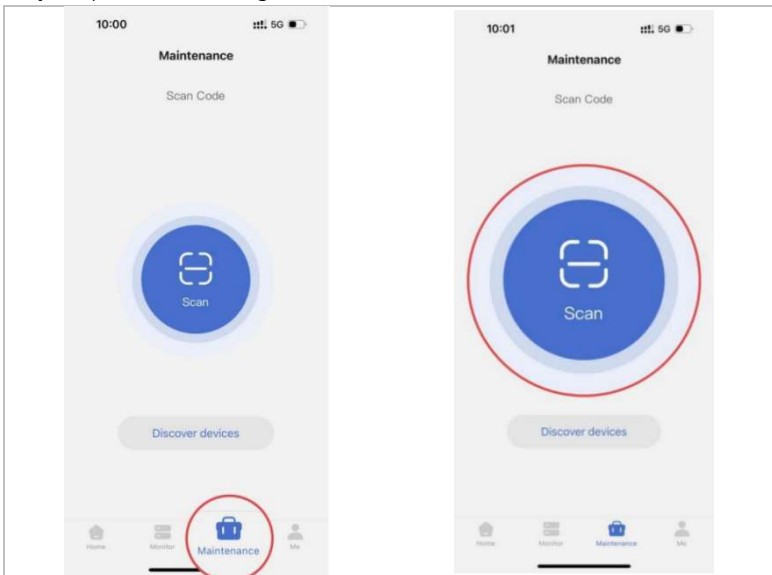

**Step3** The app aligns the QR code of the logger and scans it.



**Step 4** Select wifi logger and enter the wifi password manually.

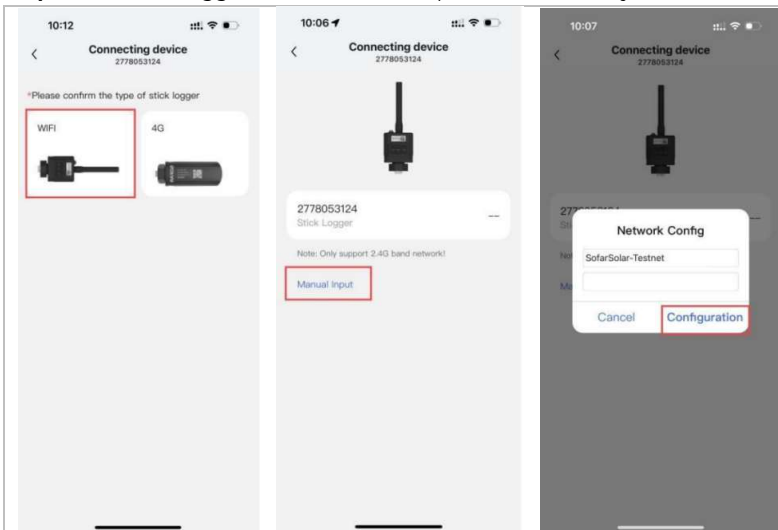

**Step 5** Follow the instructions on the app step by step.

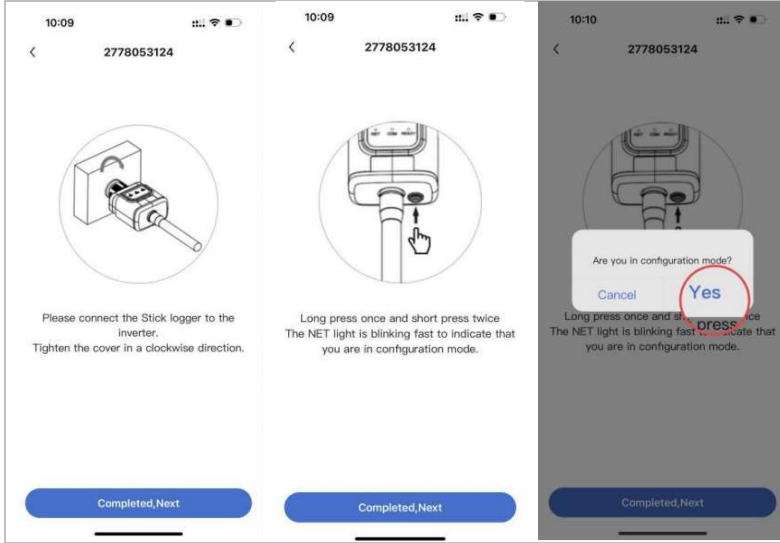

**Step 6** Waiting for the app to connect to the capture stick. After successful configuration, wait for about 5min for SofarCloud to have data reported.

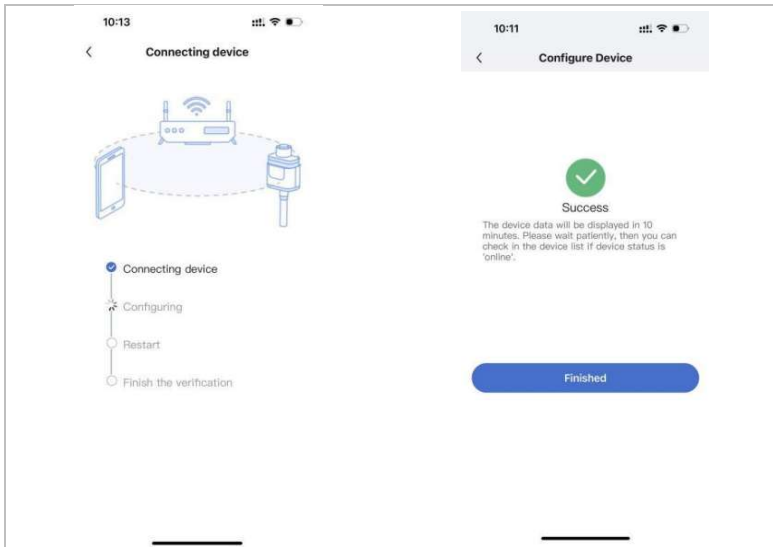

**WiFi stick status**

The LEDs on the WiFi stick provide information regarding the status:

LED	Status	Description
NET	Communication with the router	On: Connection to server successful
		Flashing (1 sec.): Connection to router successful
		Flashing (0.1 sec.): WPS mode active
		Off: No connection to router
COM	Communication with inverter	Flashing (1 sec.): Communication with inverter
		On: Logger connected to inverter
		Off: No connection to inverter
READY	Logger status	Flashing (1 sec.): Normal status
		Flashing (0.1 sec.): Reset running
		Off: Error status

**Reset button**

Keystroke	Description
1 sec.	WPS mode
5 sec.	Restart
10 sec.	Restart (reset)

## 5 Energy storage system construction

- ▶ ESI series inverters have different control schemes when matched with different batteries, please select the corresponding battery in the inverter according to the software chapter.

### 5.1 Energy storage system with BTS 5K batteries

#### 5.1.1 Configurations BTS Battery for Stacked Inverter

Stacked installation supports expansion of up to six batteries. One inverter module supports up to six batteries expansion modules. The BTS 5K battery system has a nominal capacity of 5.12 kWh and an ESI system is available in configurations from 5.12 kWh to 30.72 kWh.

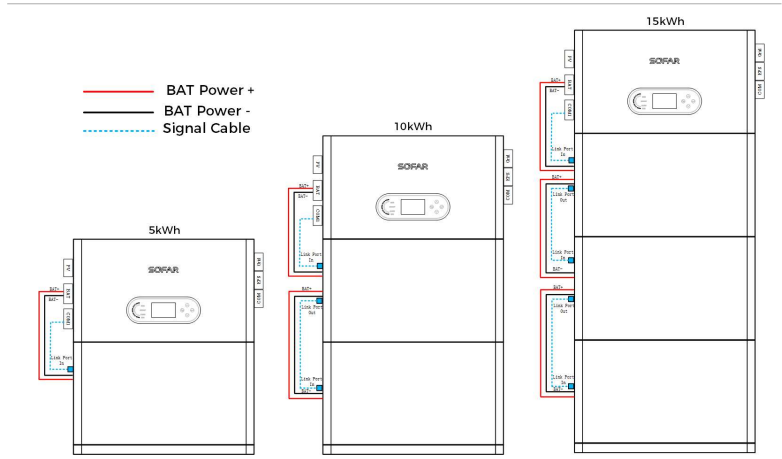

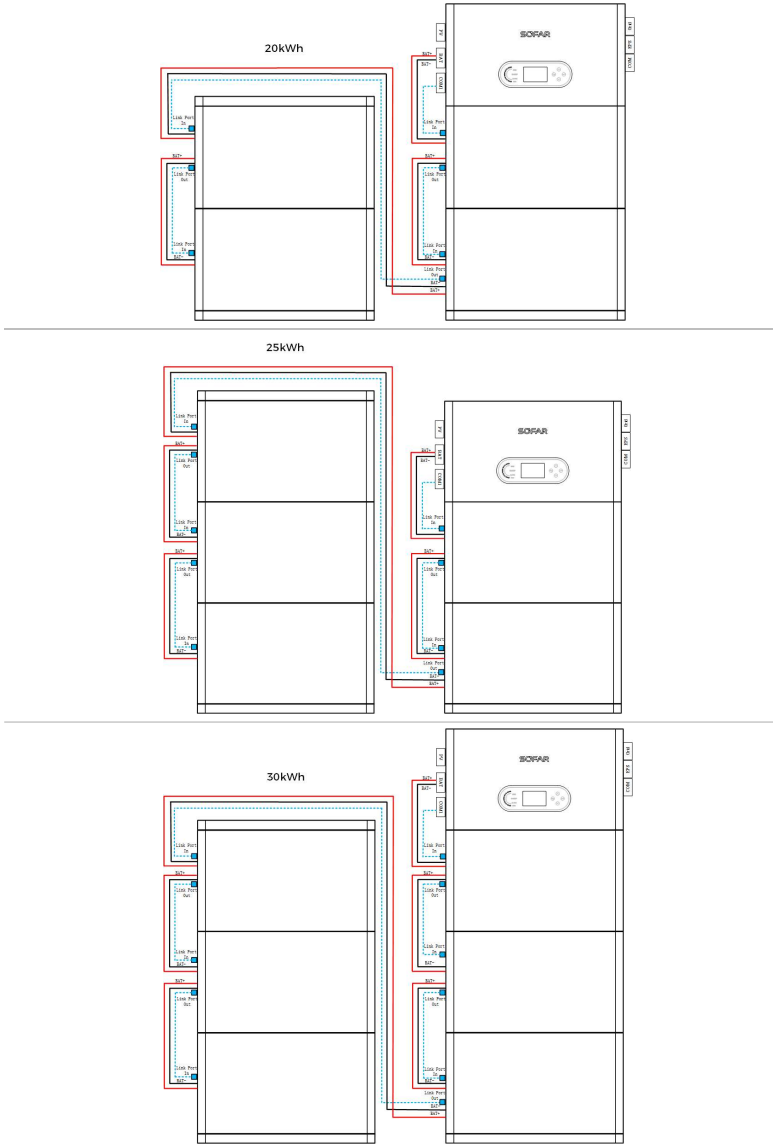

Figure 5-1 Number of battery modules and system capacity

### 5.1.2 Confirmation of mounting position

ESI series products can be stacked and installed with batteries to form a photovoltaic storage system. The location of the inverters and batteries needs to be evaluated at the beginning of the installation, as shown in the following diagram:

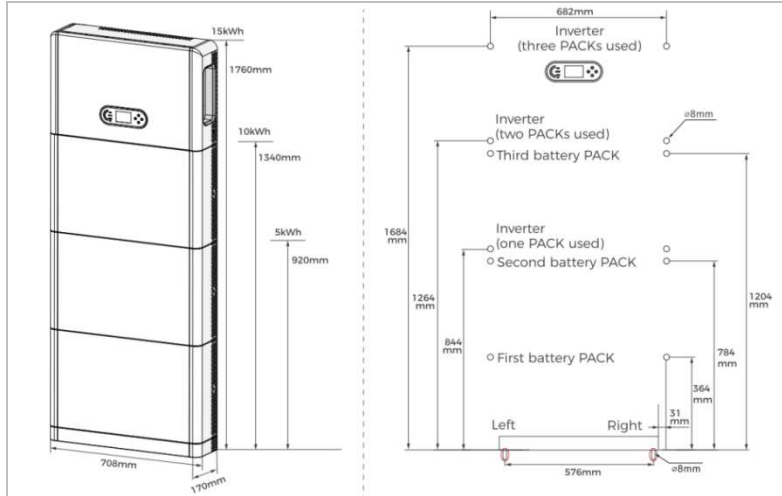

Figure 5-2 installation dimensions diagram

Stack the battery modules according to the battery installation manual and fasten the inverter according to the holes at the top.

### 5.1.3 Mounting battery base

1. Place the pedestal against a wall and keep it 10 to 25mm away from the wall. Adjust the hole positions using a level, and mark the hole positions using a marker.
2. To install the pedestal, remove the pedestal, drill holes using a hammer drill ( $\varnothing$  8mm, depth range 60-65 mm), and tighten expansion screws to ensure that the base is securely installed.
3. Use a marker to mark the holes for securing the battery module and inverter according to the dimensions shown in the figure below.

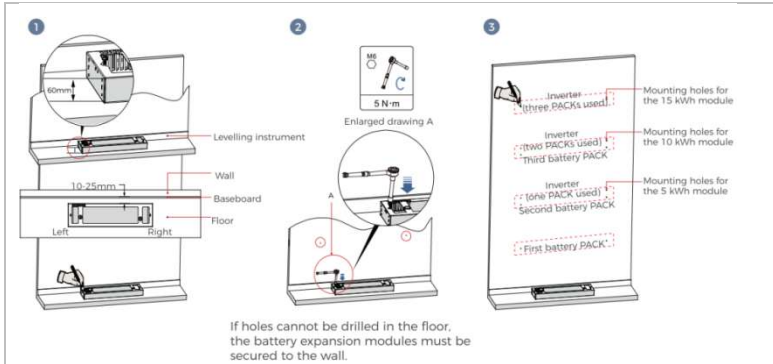

Figure 5-3 Pedestal installation

### 5.1.4 Stacked Batteries & Inverters

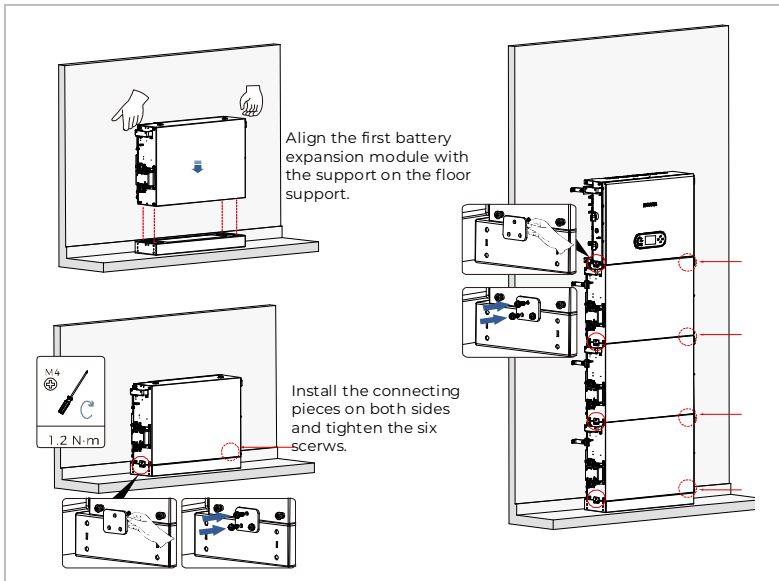

Figure 5-4 Battery module and inverter installation diagram

1. Place the first battery module on the base.
2. Install connectors on both sides and tighten the six screws with a cross screwdriver.

3. Install the remaining battery modules and BDU from bottom to top. (Before installing the next module, ensure that the screws on the side connectors of the previous module are firmly installed.)

### 5.1.5 Anti-tip bracket installation

1. Drill holes with a hammer drill ( $\varnothing$  8mm, depth range 60-65 mm).
2. Reposition and drill the holes, if the original one has a large deviation. Install the anti-tip bracket B on the wall, and fasten expansion bolt.
3. Adjust the anti-tip bracket A, make sure the holes are matched between anti-tip bracket A and anti-tip bracket B.
4. Connect and fix the anti-tip bracket A and anti-tip bracket B with M6\*16 screws.

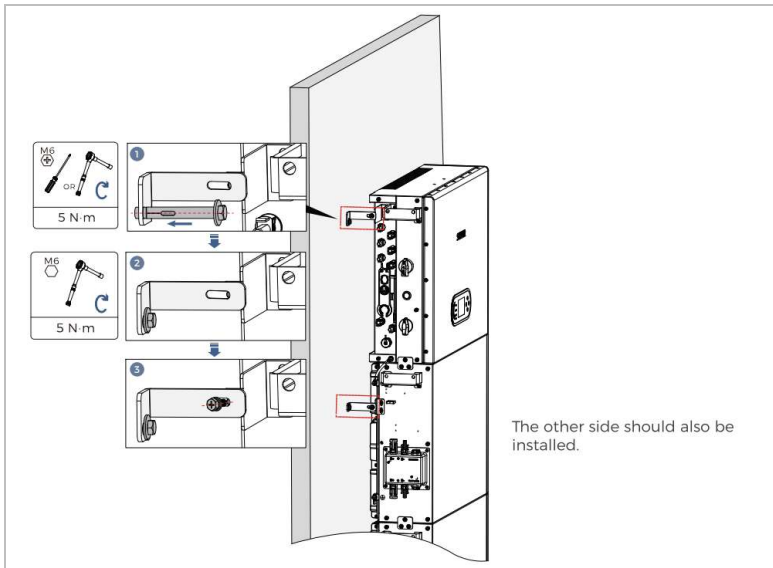

Figure 5-5 Schematic diagram of wall fixing installation

### 5.1.6 Installation of PE cable

The inverter accessory rack contains a ground wire connected to the battery. Install the crimped ring terminal and the washer with the M6 screws and tighten these with a torque of 5 N · m using an Allen key. All inverter and battery enclosures must be connected to an PE cable.

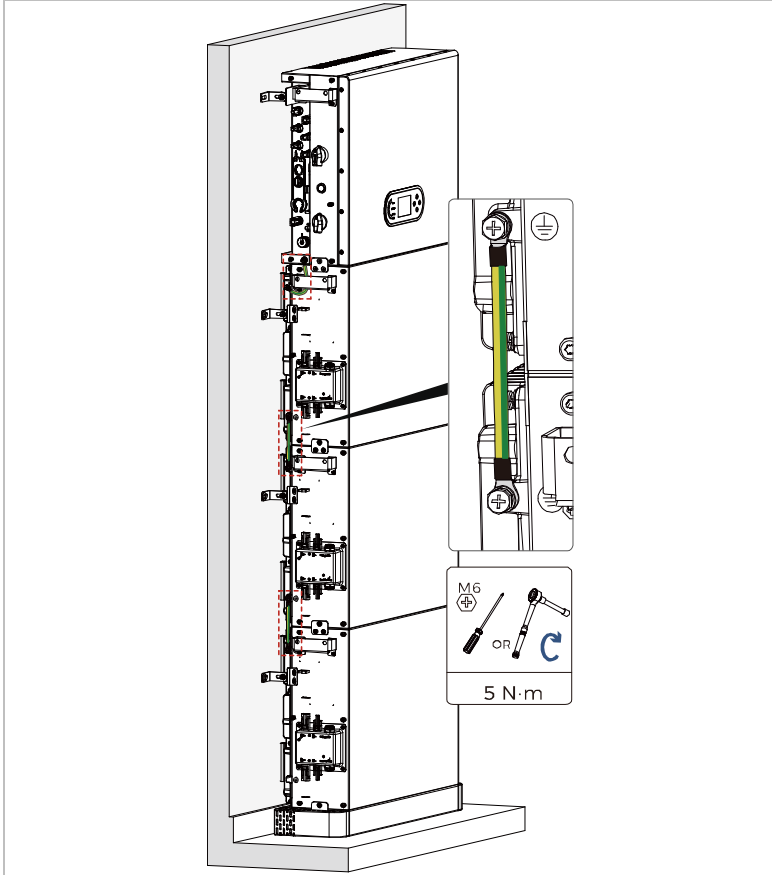

Figure 5-6 Connecting PGND cable(c)

The ground wire on the right side should be made by the installer. It is recommended.

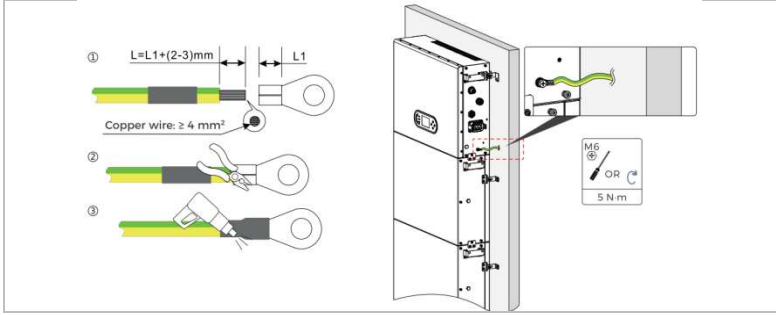

Figure 5-7 Connecting PGND cable(d)

### 5.1.7 Power cables connection

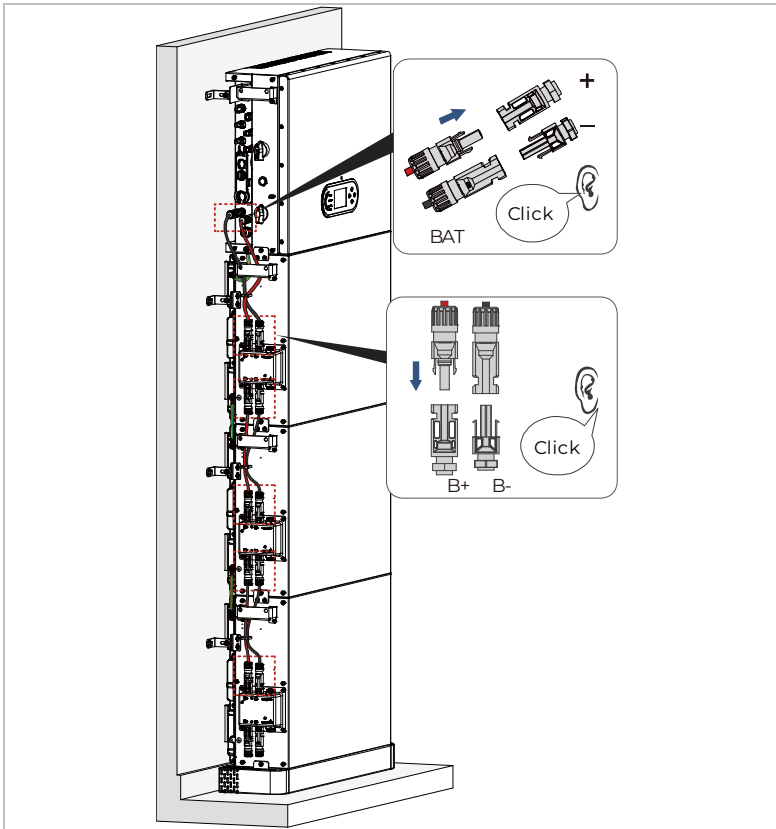

Figure 5-8 Connection of battery internal DC terminal

Connect the power ports (BAT+, BAT-) of the inverter to the cascading positive and negative power cables (B+, B-) of the battery module. Connect the remaining battery modules from top to bottom, and secure the cables with cable ties. Ensure that the cables are securely connected.

### 5.1.8 BMS communication cable connection

Connect the inverter “BAT CAN” to the battery module Link Port in. Connect the communication terminals of the inverter and the battery module from top to bottom according to the diagram below and secure them with cable ties. For the communication cables, tighten the large nut first, then the small nut. In addition, install a matching termination resistor on the communication port of the last battery module in the system.

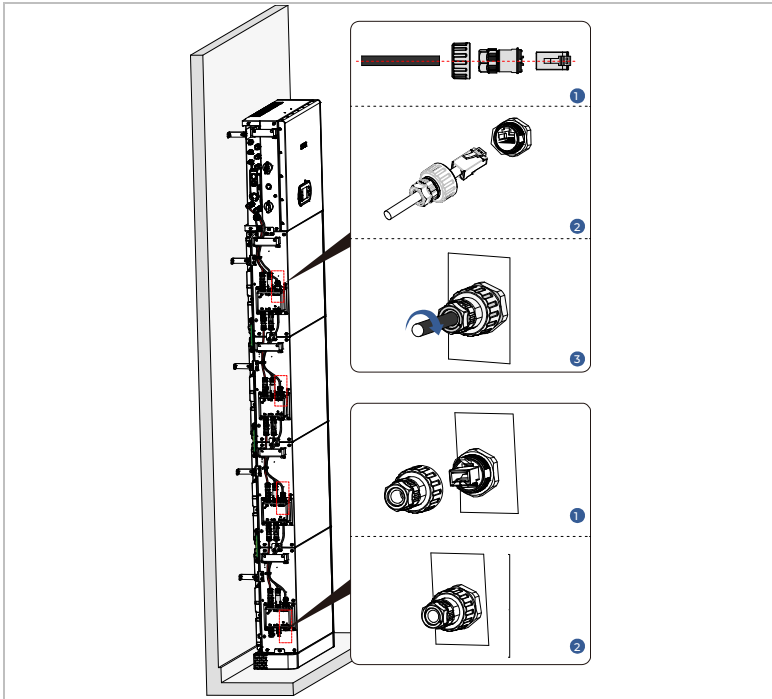

Figure 5-9 Internal signal cable connection

- The battery inputs of different inverters should not be connected in parallel.

5.1.9 Install the cover

After electrical connections are complete and cable connections are correct and reliable, install the external protective cover and secure it using screws.

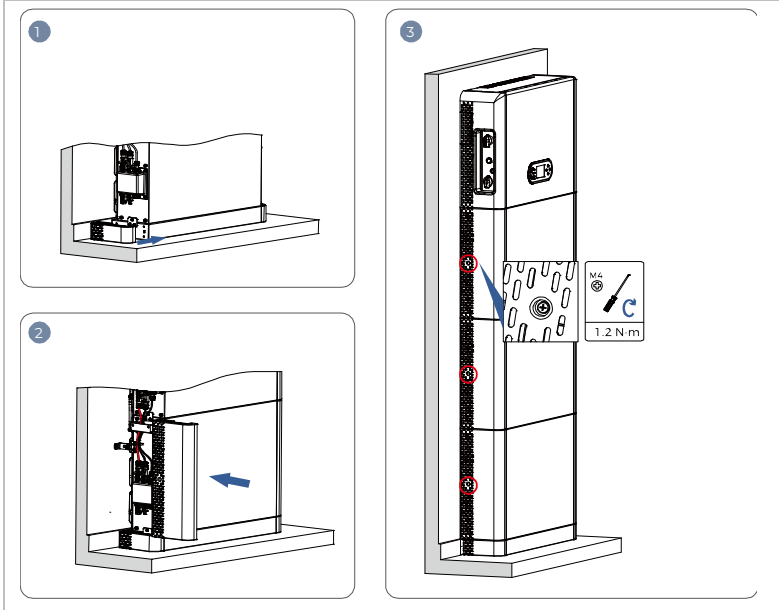

Figure 5-10 Install the cover

## 6 Commissioning the inverter

### 6.1 Safety test before commissioning

#### NOTICE

##### Check the voltage range

- ▶ Ensure that the DC and AC voltages are within the permissible range of the inverter.

### 6.2 Double Check

Please ensure that the inverter and all the wiring are installed correctly, securely, and reliably, and that all environment requirements are met.

1. Inverter is firmly fastened to the wall.
2. PV+/PV- wires are firmly connected, polarity and voltage are correct.
3. BAT+/BAT- wires are firmly connected, polarity and voltage are correct.
4. DC isolator is correctly connected between battery & inverter, DC isolator: OFF.
5. GRID/BACKUP cables are firmly / correctly connected.
6. AC circuit breaker is correctly connected between inverter GRID port & GRID, circuit breaker: OFF.
7. AC circuit breaker is correctly connected between inverter BACKUP port & critical load, circuit breaker: OFF.
8. For lithium battery, please ensure that the communication cable has been correctly connected.

### 6.3 Starting the inverter

Please follow below steps to switch the inverter ON.

1. Make sure there's no power generation in inverter from grid.
2. Turn ON DC switch.
3. Turn ON DC isolator between battery & inverter. Switch ON the battery.
4. Turn ON AC circuit breaker between the inverter GRID port & GRID.

5. Turn ON AC circuit breaker between the inverter BACKUP port & critical load.
6. Inverter should start to operate now.

## 6.4 Initial setup

You need to set the following parameters before inverter starts to operate.

Parameter	Note
1. Language setting	The default is English
2. System time setting	If you are connected to the server or using the App, the time is set to the local time automatically
3. Safety parameter import	Refer to the country code table below and select country and code.
4. Application scenario setting	According to the user application scenario configuration, set the parameters of PV port, BAT port, GRID port and BACKUP port
5. Work mode setting	Set different working modes, and configure parameters for different working modes (Self-use, Feed-in Priority, Peak Shaving, Time-of-use, Passive), and set battery energy storage parameters (Charge Cut-off SOC, On-grid Discharge Cut-off SOC, Off-grid Discharge Cut-off SOC, Off-grid Discharge Recovery SOC).

The default operating mode is the Self-use Mode.

### 6.4.1 Configuring the battery setup

The ESI-5...12K-TI models have one battery input (max. current 25 A).

### 6.4.2 Configuring Parallel Inverter System

To increase the system's BACKUP and grid power, the ESI-5...12K-TI can be parallelly connected at the Grid port and the BACKUP port.

For the communication setup, please follow the following steps:

1. Set the Master unit

## 2. Set the Slave units

- ▶ Each inverter must have a unique parallel address

### **Setting the country code**

- ▶ Different distribution network operators in various countries have differing requirements for the grid connection of grid-coupled PV inverters.
- ▶ Ensure that you have selected the correct country code according to regional authority requirements, and consult a qualified electrician or employees of electrical safety authorities.
- ▶ SOFAR is not responsible for the consequences of selecting the incorrect country code.
- ▶ The selected country code influences the device grid monitoring. The inverter continuously checks the set limits and, if required, disconnects the device from the grid.

## 7 Operation of the device

This chapter describes the LCD and LED displays of the ESI-5...12K-T1 inverter.

### 7.1 Control panel and display field

#### 7.1.1 Buttons and display lights



#### Buttons

Button	Name	Description
	Back	Previous screen, enter menu
	Up	Select previous menu item, increase setting value
	Down	Select next menu item, decrease setting value
	Enter	Enter Menu item, select next digit, confirm setting



**LEDs**

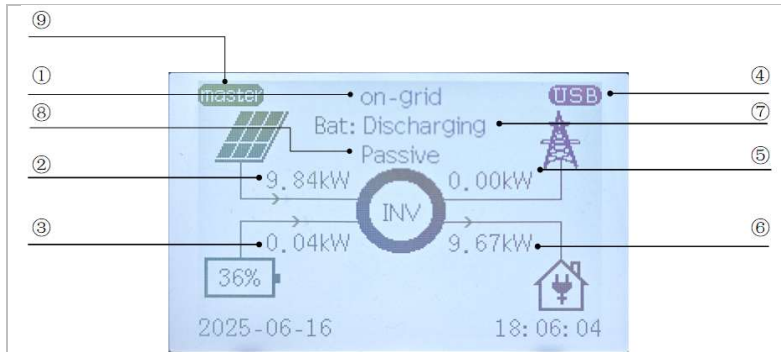

State	Colour	State
On-grid	Green	Normal
	Green (flashing)	Standby
Off-grid	Green	Normal
	Green (flashing)	Standby
Alarm	Red	Error

## 7.2 Standard display

The screen shows all relevant information of the inverter:



① <b>Current state of the inverter</b>	Used to display the current working status of the inverter, including grid-connected, off-grid and standby.
② <b>PV Power</b>	For displaying photovoltaic power.
③ <b>Battery Power</b>	For displaying BAT charge or discharge power. No battery marking here if no battery is connected
④ <b>Accessory</b>	   This is used to display the accessories currently connected to the inverter, including the capture stick, USB, and smart meter.
⑤ <b>Grid Power</b>	Power flowing into or out of the grid

⑥ Home Consumption		Energy consumed by household loads
⑦ PV channel enable state		Used to display the current number of PV input channels open
⑧ Work Mode		Displays the current operating mode of the inverter, the specific operating mode is described in 7.3
⑨ Master-slave state	 	Used to connect multiple inverters in parallel, indicating whether the current inverter is in the master or slave position.

### 7.3 Work modes

The ESI-5...12K-T1 comes with several integrated energy management modes.

#### 7.3.1 Self-use Mode

In the Self-use mode, the inverter will automatically charge and discharge the battery according to the following rules:

**Setting Method 1:** Battery First: Disabled; Charging From Grid: Disabled The priority of power supply: PV, Battery, Grid. The priority of power consumption: Loads, Battery, Grid.

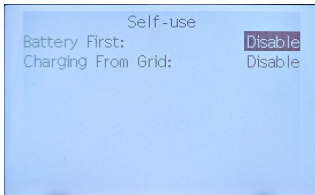

**Set Self-use Mode 1**

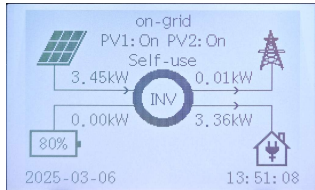

If PV generation equals the load consumption ( $\Delta P < 100\text{ W}$ ), the inverter won't charge or discharge the battery

OPERATION OF THE DEVICE

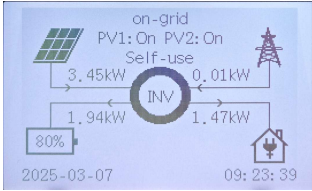

If PV generation is larger than the load consumption, the surplus power is stored in the battery

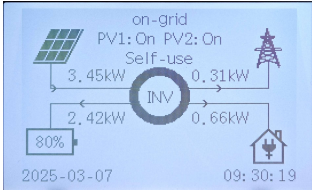

If the battery is full or at maximum charging power, the excess power will be exported to the grid

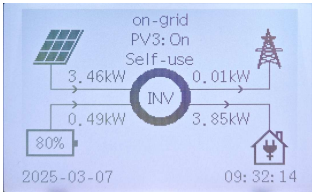

If the PV generation is less than the load consumption, it will discharge the battery to supply power to the load.

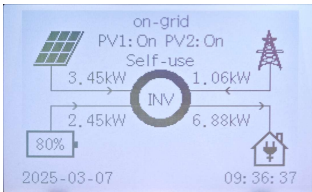

If PV generation plus Battery discharge power is less than the load, the inverter will import power from the grid.

- ▶ If it is not allowed to export power to the grid, an energy meter and/or CT needs to be installed, and the "feed-in limitation" function needs to be enabled.

**Setting Method 2:** Battery First : Enabled, Battery First Cut-off SOC : 90%; Charging From Grid: Disabled. The priority of power supply: PV, Battery, Grid. The priority of power consumption: Loads, Battery, Grid.

Self-use

Battery First:	Enable
Battery First Cut-off SOC:	090%
Charging From Grid:	Disable

**Set Self-use Mode 2**

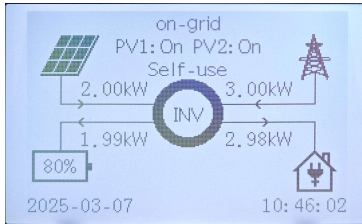

If the PV power is less than or equal to the battery charging power and the battery SOC is less than 90%, the inverter prioritizes charging the battery and the grid supplies power to the household loads.

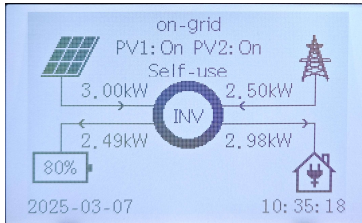

If the PV generation power is greater than the battery charging power and the battery SOC is less than 90%, the inverter prioritizes charging the batteries, and the remaining energy generated by the PV power is used with the grid to power the household loads.

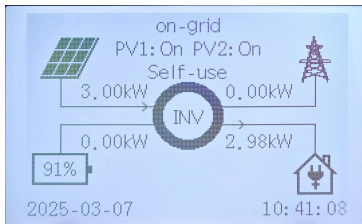

If the batteries continue to charge and the battery SOC reaches 90%, the inverter stops charging the batteries and all of the energy generated by the PV power is supplied to the household loads.

**Setting Method 3:** Bat Priority Control : Disabled; Import to Charge Battery : Enabled. When the inlet battery charging enable is turned on, the user can set the amount of specific charging time range, the maximum battery charging power, and the maximum cut-off SOC for forced charging through the LCD.

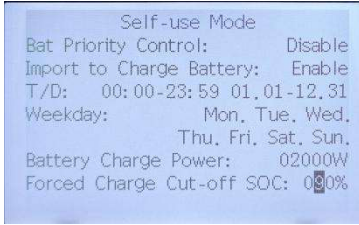

**Setting Method 3**

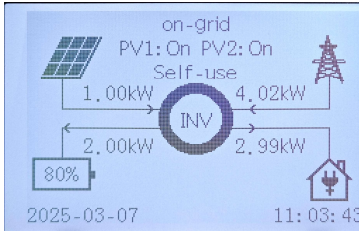

If the PV power is less than the battery charging power and the battery SOC is less than 90%, the inverter gives priority to charging the battery while taking power from the grid to charge the battery, and the load power is provided by the grid.

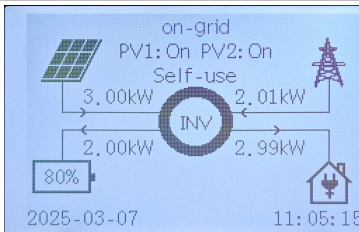

If the PV generation power is greater than the battery charging power and the battery SOC is less than 90%, the inverter prioritizes charging the batteries, and the remaining energy generated by the PV power is used with the grid to power the household loads.

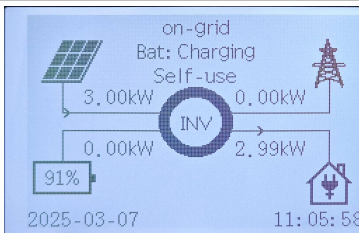

If the batteries continue to charge and the battery SOC reaches 90%, the inverter stops charging the batteries and all of the energy generated by the PV power is supplied to the household loads.

**Setting Method 4:** Battery First : Enabled; Charging From Grid : Enabled. In this mode, the Battery First and Battery First Cut-off SOC functions are in effect at the same time, see Setting Method2, 3 for details.

Self-use	
Battery First:	Enable
Battery First Cut-off SOC:	080%
Charging From Grid:	Enable
T/D:	00:00-23:59 01,01-12,31
Weekday:	Mon, Tue, Wed, Thu, Fri, Sat, Sun.
Charging Power Limit:	02000W
Charge Cut-off SOC:	080%

**Setting Method 4**

### 7.3.2 Feed-in Priority Mode

With the Feed-in Priority Mode, In this mode, the user can set the maximum feeder power, which is used to generate the remaining energy after the PV power meets the load consumption.

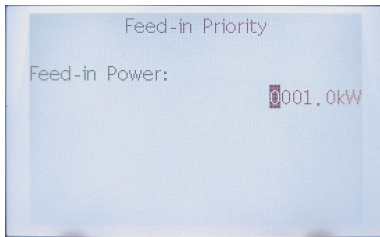

**Feed-in Priority Mode**

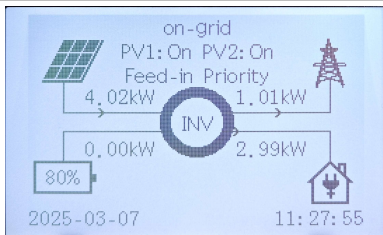

In this mode, the user can set the maximum feeder power, when the PV power minus the load consumption power is less than or equal to the feeder power (for example, 1kW), the excess energy generated by the PV power generation is delivered to the grid.

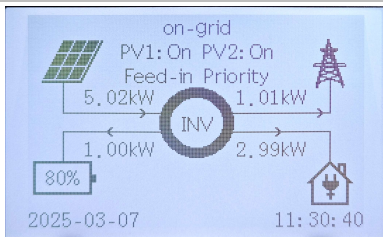

In this mode, the user can set the maximum feeder power, when the PV power minus the load consumption power is greater than the feeder power (for example, 1kW), the extra energy will be used to charge the battery.

### 7.3.3 Peak Shaving Mode

Used to limit the maximum power priority purchased from the grid. The maximum purchasing power can be set in this mode. When the system preferentially buys more power from the grid than the set value, the battery starts discharging and stabilizes the system power at the set value.

**Application:**

Peak Shaving Mode allows the grid to supply power to the load first. Applicable to the occasions where electricity price is charged according to electricity

consumption and the occasions where the power grid is weak. In the weak grid situation, batteries start only when the load power exceeds a certain value, which reduces the maximum power of the connecting point and prolongs the battery life.

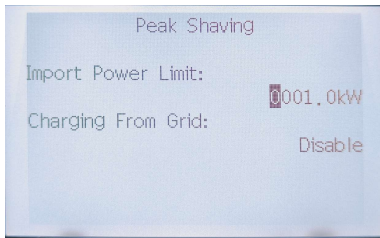

Charging From Grid: Disable

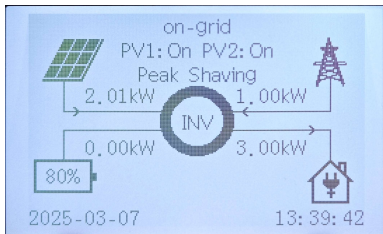

When the PV power is not enough to supply the load consumption, the grid starts to supply power to the load, and the maximum power taken from the grid does not exceed the Priority Import Power.

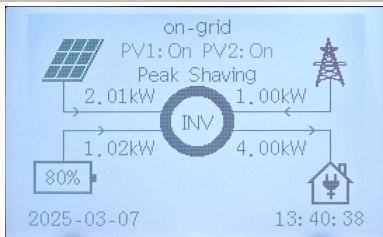

When the PV power and Priority Import Power are also insufficient to supply the load consumption, the battery starts discharging to supply the load consumption at the same time.

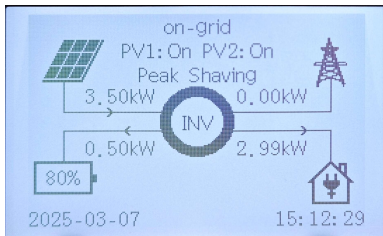

When the photovoltaic power generation is greater than the load consumption, the excess energy to charge the battery, when the battery SOC is greater than the set value, the excess energy flows to the power grid.

OPERATION OF THE DEVICE

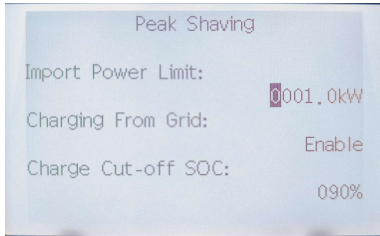

Charging From Grid: Enable

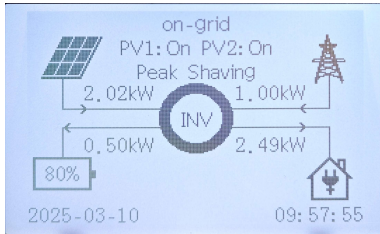

When “Charging From Grid” is enabled and there is not enough PV power to supply the load and the load consumes less than the Import Power Limit, the grid starts to supply power, which is less than then Import Power Limit setting.

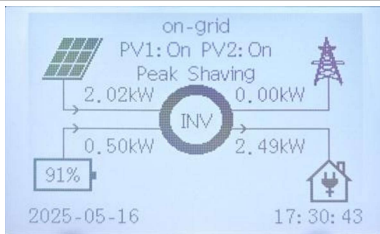

When the battery SOC is greater than the set value, the battery and the PV supply power to the load at the same time.

### 7.3.4 Time-of-use Mode

Under the Time-of-use Mode, the work modes that can be selected in the rule entries include: Charge, Discharge, Self-use, Feed-in Priority, Peak Shaving.

With the Discharge or Charge Mode, you can define fixed times of the day to charge or discharge the battery with a certain power. For details on how to use the other modes, please refer to the corresponding mode descriptions in sections 7.3.1 - 7.3.4.

<p>Time-of-use Mode</p> <p>Rules 1: Enable</p> <p>Mode: <b>Discharge</b></p> <p>Time: 01:00-05:00</p> <p>Date: 01.01-12.31</p> <p>Weekday: Mon, Tue, Wed, Thu, Fri, Sat, Sun.</p> <p>Power: 02500W</p> <p>SOC: 030%</p>	<p>Time-of-use Mode</p> <p>Rules 0: Enable</p> <p>Mode: <b>Charge</b></p> <p>Time: 01:00-05:00</p> <p>Date: 01.01-12.31</p> <p>Weekday: Mon, Tue, Wed, Thu, Fri, Sat, Sun.</p> <p>Power: 02500W</p> <p>SOC: 100%</p>
<p>Time-of-use</p> <p>Rules 2: Enable</p> <p>Mode: <b>Peak Shaving</b></p> <p>Time: 01:00-05:00</p> <p>Date: 01.31-12.31</p> <p>Weekday: Mon, Tue, Wed, Thu, Fri, Sat, Sun.</p> <p>Charging From Grid: Disable</p> <p>Power-SOC: 0000,1kW-100%</p>	<p>Time-of-use</p> <p>Rules 2: Enable</p> <p>Mode: <b>Feed-in Priority</b></p> <p>Time: 01:00-05:00</p> <p>Date: 01.31-12.31</p> <p>Weekday: Mon, Tue, Wed, Thu, Fri, Sat, Sun.</p> <p>Power: 0000,1kW</p>
<p>Time-of-use</p> <p>Rules 2: Enable</p> <p>Mode: <b>Self-use</b></p> <p>Time: 01:00-05:00</p> <p>Date: 01.01-12.31</p> <p>Weekday: Mon, Tue, Wed, Thu, Fri, Sat, Sun.</p> <p>Battery First: Disable</p> <p>Battery First Cut-off SOC: 030%</p>	

In the above Discharge/Charge example, Rule 0: the battery will be charged with 2.5 kW between 1 and 5 o'clock at night, and Rule1: discharged with 2.5 kW between 1 and 5 o'clock. In case of conflict between Rule 0 and Rule 1, Rule 0 takes precedence.

### 7.3.5 Passive Mode

The passive mode is used in systems with external energy management systems. The inverter's operation will be controlled by the external controller using the Modbus RTU protocol. Please contact SOFAR if you need the Modbus protocol definition for this device.

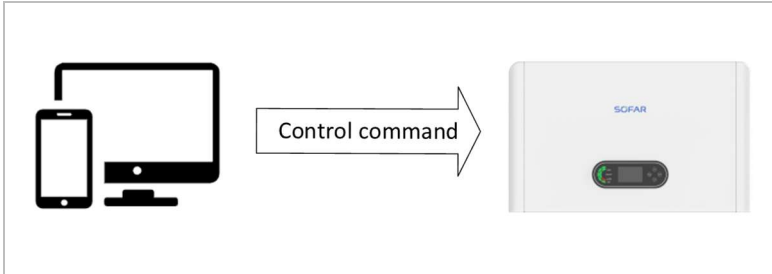

### 7.3.6 Energy Storage Settings

In this interface the user can set four battery charging and discharging states, Charge Limit SOC, On-grid Discharge Limit SOC, Off-grid Discharge Limit SOC, Off-grid Recovery Discharge SOC.

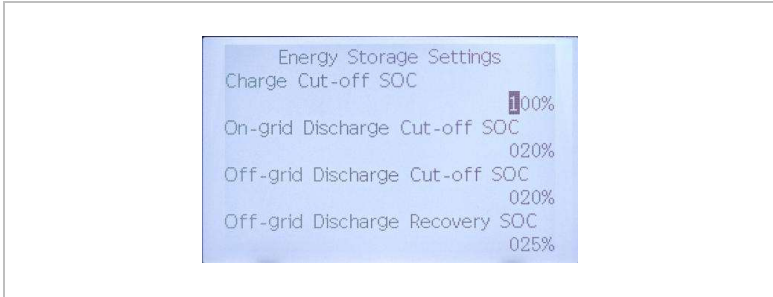

## 7.4 Menu structure

Press the button  to bring up the main menu.

### 7.4.1 Main menu

---

**System Information**

---

**Real-time Information**

---

**Event List**

---

**Energy Statistic**

---

**System Settings**

---

**Advanced Settings**

---

**Firmware Upgrade**

---

- ▶ The menu layout may vary according to different firmware versions.

## 7.4.2 “System Information” menu

<b>1.Inverter</b>	
Inverter(1)	Serial Number, Rated Power, Firmware Version, Grid Code
Inverter(2)	Bat Channel, PV Channel 1, PV Channel 2, PV Channel 3
Inverter(3)	Work Mode, RS485 Address, BACKUP, IV Curve Scan
Inverter(4)	Logic Interface, Power Factor, Feed-in Limit, Insulation Resistance
Inverter(5)	Parallel, Automatic Battery Active, Unbalanced Support
Inverter(6)	Safety Parameter
<b>2.Battery</b>	
Battery (1)	Battery Type, Max Charge Current, Max Discharge Current
Battery (2)	Charge Limit SOC, On-grid Discharge Limit SOC, Off-grid Discharge Limit SOC, Off-grid Recovery Discharge SOC
Battery (3)	Serial Number
Battery (4)	Firmware Version

**7.4.3 “Real-time Information” menu**

<b>1.PV</b>	
1.1 PV(1)	PV1 Voltage, PV1 Current, PV1 Power, PV2 Voltage, PV2 Current, PV2 Power
1.2 PV(2)	PV3 Voltage, PV3 Current, PV3 Power, External PV Power
<b>2.BAT</b>	
2.1BAT Port Info	Voltage, Current, Power, SOC, State
2.2BAT real info	Voltage, Current, Power, SOC, Max Charge Current, Max Discharge Current, Max Cell Temp, Min Cell Temp
<b>3.GRID</b>	
	Voltage R, Voltage S, Voltage T, Power R, Power S, Power T, Frequency
<b>4.BACKUP</b>	
	Voltage R, Voltage S, Voltage T, Power R, Power S, Power T, Frequency
<b>5.Normal Load</b>	
	Power
<b>6.Total Load</b>	
	Power
<b>7.Wallbox</b>	
7.1Wallbox(1)	Communication, State, Power, Total Energy, Fault Code
7.2 Wallbox(2)	Voltage R, Voltage S, Voltage T, Current R, Current S, Current T

**7.4.4 “Event List” menu**

The event list is used to display the real time event recordings, including the total number of events and each specific ID no. and event time. The most recent events are listed at the top.

<b>Event list</b>	
<b>1、 Current Event List</b>	Show latest event
<b>2、 History Event List</b>	Show event history
<b>Fault information</b>	001 ID04 06150825 (display of the event sequence number, event ID number and time

that the event takes place. Press"<Enter>"to toggle between event name and trigger time.)

### 7.4.5 “Energy Statistics” menu

In this menu, you can view the PV, battery, load, and grid energy usage status of different channels in real time and different years, months and days.

Today	Press Down button to move between items
Month	Shows PV, Load, Export, Import, Charge,
Year	Discharge Energy (kWh) for the selected
Lifetime	period

### 7.4.6 “System Settings” menu

In this menu you can do the basic settings which are needed to operate the device.

<b>1.Language</b>	<b>Sets the display language</b>
<b>2.Date &amp; Time</b>	Sets the date and time of the inverter
<b>3.Grid Code</b>	Sets the country and grid code
<b>4.Device Port Management</b>	Sets the parameters about PV port, BAT port, GRID port, BACKUP port.
<b>4.1 PV</b>	Set PV port.
<b>4.1.1 PV1</b>	
<b>4.1.2 PV2</b>	Set PV input: Select 'PV' for photovoltaic scenarios, otherwise set to disabled.
<b>4.1.3 PV3</b>	
<b>4.2 BAT</b>	Set battery port: Select 'BTS 5K' for battery operation scenarios, otherwise set to disabled.
<b>4.3 GRID</b>	Set grid port mode to grid connection or generator connection
<b>4.3.1 GRID</b>	Set grid port mode to grid-connected.
<b>4.3.2 GEN</b>	Set grid port mode to generator.
<b>4.3.2.1 Manual</b>	Set the generator to manual mode, then configure its rated power.
<b>4.3.2.1 Auto</b>	Set generator to auto mode with start/stop SOC and rated power.

<b>4.4 BACKUP</b>	Enable / disable the off-grid mode. It is only available if a battery is connected
<b>5.Work Mode</b>	Sets the work mode and energy storage setting
<b>5.1 Work Mode</b>	Select between Self-use(Standard), Feed-in Priority, Peak Shaving, Time-of-use, Passive. See “7.3 Work Modes” chapter for details.
<b>5.2 Energy Storage Settings</b>	Sets Charge Limit SOC, On-grid Discharge Limit SOC, Off-grid Discharge Limit SOC, Off-grid Recovery Discharge SOC.
<b>6.Auto test</b>	Selection of Italian rapid and standardized tests for functional verification.
<b>7.RS485 Communication</b>	Enter the Modbus address (when several inverters require simultaneous monitoring), standard: 01 Baud Rate: The default baud rate is 9600
<b>8.Wallbox</b>	Setting up the different operating modes of the Wallbox.
<b>8.1 Charge Now</b>	Sets Wallbox Control, Charging Current, Charging From Battery.
<b>8.2 Scheduled</b>	Sets different rules, Charing Start Time, Charing End Time, Charging Current, Charging From Battery.
<b>8.3 ECO Mode</b>	Sets Charging From Battery.

### 7.4.7 “Advanced Settings” menu

#### Password

- ▶ Several settings require a password to be entered (the standard password is 0715/0001).

In this menu you can do advanced settings.

#### 1. Battery

##### 1.1 30 Days SOC Calibration

Enable / Disable.  
When the BTS-5K battery is connected, if "SOC Calibration" is enabled, the inverter will forcibly charge until it is fully charged once a month.

##### 1.2 Battery Active

Sets Auto Active Control and Force Active. (Only available for BTS battery type.)

##### 1.2.1 Auto Active

Enable / Disable.  
If Automatic activation is enabled, the inverter will activate the battery when the inverter need to discharge or charge the battery according to the operational mode settings.  
If automatic activation is disabled, battery activation can be performed once via 'Once Manual Active'.

##### 1.2.2 Once Manual Active

Select 'Once Manual Active' for a one-time battery activation.

#### 2. Feed-in Limit Control

Activates or deactivates the feed-in power function of the inverter and sets the maximum feed-in power. This function must be used together with an external current transformer or the smart meter. Details regarding this can be found in the "Communications interfaces" chapter of this manual.

##### 2.1 Feed-in Limitation Mode

Disable: Do not use this function  
Three phase Sum limit: the sum of all phases is regulated (balancing counting as is common in Germany).  
Feed-in Limitation: the power of the feeding-in phases is limited.

##### 2.2 Feed-in Limit Power

Set the power size of the inverter flowing to the grid, when detecting a

	current flowing to the grid (reverse current), reduce the output power of the inverter, so that the power flowing from the inverter to the grid is always connected to a state smaller than the set value, so as to realize the anti-reverse current and not to send the excess power to the grid.
<b>2.3 Hard Limit Control</b>	This feature is required by Australian safety standards.
<b>3.IV Curve Scan</b>	(Only set with PV channel.) Cyclical scanning of the IV curve in order to find the global point of the maximum output. Advisable in the case of shaded solar generators
<b>3.1 Scan Control</b>	Enable / disable IV curve scan function
<b>3.2 Scan Period</b>	Set scan period in minutes
<b>3.3 Once Manual Scan</b>	Manually start IV curve scanning
<b>4.Logic interface</b>	Activates or deactivates logical interfaces. Details regarding this can be found in the "Communications interfaces" chapter of this manual
<b>5.Restore Factory Settings</b>	Resets stored data in the inverter
<b>5.1 Clear energy Data</b>	Clears total power production
<b>5.2 Clear Events</b>	Clears historical events
<b>5.3 Reset Settings</b>	Restore parameters to factory default settings.
<b>6.Parallel setting</b>	Defines configuration for parallel inverter operation (Master/Slave)
<b>6.1 Parallel Control</b>	For inverters connected with Link port to each other, you set Parallel Control to "Enable"
<b>6.2 Master-Slave</b>	One Inverter need to be set as Master, all other inverters need to be set to Slave.
<b>6.3 Parallel Address</b>	Set each inverter with an individual parallel address. (It is an independent number from Modbus ID)
<b>7.Switch On / Off</b>	The inverter can be switched on, switched off, set to standby or set to normal operating mode, which can be useful for installation or maintenance work

<b>8.Unbalanced Support</b>	<p>Default setting: disabled</p> <p>In situations where the customer only wants to support the local loads or has a zero-export limit across all three phases. When used in conjunction with the supplied three-phase energy meter and with this option set to "enable", the per phase output current of the inverter will respond independently.</p> <p>Important: for this function to operate properly, the phase on the energy meter must correlate to the corresponding phase when it is wired into the inverter.</p>
<b>9.PCC Import Limit</b>	<p>PCC Import Limit Control: Control whether the PCC power control function is enabled.</p> <p>PCC Import Limit Power: Power upper limit, that is, the maximum power that can be purchased from the PCC. (When the load is greater than the maximum power purchased from the PCC, the load power priority is higher to meet the load power priority.)</p>
<b>10.Set PCC Power Offset</b>	Calibration for PCC power calculation.
<b>11.BACKUP GFCI</b>	Activates RCD type B monitoring in off-grid mode (300 mA)
<b>12.Neutral Point Grounding</b>	When using off-grid mode, ensure that neutral ground is enabled. For Australia, South Africa, and New Zealand, neutral ground is turned off by default, refer to 5.3 System Overview
<b>13.E-STOP</b>	Enable / disable Emergency Power Off function
<b>14.SG Ready</b>	<p>Timed control mode: set the start time and stop time, turn on the smart load within the start time range and turn off the smart load outside the start time range.</p> <p>Intelligent control mode: set the start time and stop time in the start time range, generating power - ordinary load power &gt; 500W (hysteresis loop parameter reservation can be set), after 1 minute to turn on the intelligent load; generating power - ordinary load</p>

	power < 0W, after 5 seconds to turn off the intelligent load.
<b>15.ATS/12V Control</b>	(The inverter is not allowed to set for the slave machine.)
<b>15.1 Disable</b>	No use this function
<b>15.2 Generator Control</b>	Can start and stop a generator
<b>15.3 Off-grid: 12V Turn On</b>	In off-grid mode, the dry contact interface will output a 12V signal; otherwise, the output is disabled.
<b>15.4 Off-grid: 12V Turn Off</b>	In off-grid mode, the output is disabled; otherwise, the dry contact interface will output a 12V signal.
<b>16.PCC Meter/CT</b>	Enable / disable PCC Meter/CT function

- ▶ The inverter has built-in relays to control the short circuit of the load N line to ground when off-grid.
- ▶ When the inverter is off-grid and the load N line and PE line are short-connected, if the power grid is restored and the load N line and PE line are still short-connected, leakage protection will be triggered and explosion hazard will not be caused.

### 7.4.8 “Firmware Upgrade” menu

The user can update the software via the USB flash drive. SOFAR will provide the firmware upgrade when it is required.

- ▶ If you want to do a firmware upgrade, please upgrade with PV input or grid status, the update will fail if only the battery is connected.

1. Insert the USB stick into the computer.
2. SOFAR will send the firmware upgrade to the user.
3. Unzip the file and copy the original file to a USB stick. Attention: The firmware upgrade file must be in the “firmware” subfolder!
4. Press the "Back" on the main interface to enter the main menu page, and select "2.Advanced Settings - Switch On/Off -Switch Off". Make the inverter shut down safely.

5. Insert the USB flash drive into the USB interface of the inverter.
6. Go to menu item "7.Firmware Upgrade" on the LCD display.
7. Enter the password (the standard password is 0715) and then select "Firmware Upgrade".
8. Enter the password (the standard password is 0715) and then select "Inverter" or "Battery".
9. The system will then sequentially update all parts. Pay attention to the displays.
10. If an error message appears, please upgrade again. If this continues many times, contact technical support for help.
11. After the update is complete, Go to menu item "Advanced Settings - Switch On/Off - Switch On" to make the inverter start up and run.
12. You can check the current firmware version in item "Inverter(1)" of the "System information" menu.

## 8 Troubleshooting handling

### 8.1 Troubleshooting

This section contains information and procedures pertaining to the remedying of potential problems with the inverter.

To carry out troubleshooting, proceed as follows:

- ▶ Check the warnings, error messages or error codes displayed on the screen of the inverter.
- ▶ If no error information is displayed on the screen, check whether the following requirements have been fulfilled:
  - ▶ Has the inverter been set up in a clean, dry, well-ventilated area?
  - ▶ Is the DC switch set to ON?
  - ▶ Are the cables sufficiently dimensioned and short enough?
  - ▶ Are the input connections, output connections and the wiring all in good condition?
  - ▶ Are the configuration settings for the relevant installation correct?
  - ▶ Are the display field and the communication cables correctly connected and undamaged?

Follow the steps below to view recorded problems: Press "Back" to enter the main menu in the normal interface. In the interface screen select "Event List", then press "OK" to enter events.

#### 8.1.1 Shutdown procedure

If the inverter needs to be shut down for electrical inspection, please follow the following steps:

1. Press the "Back" on the main interface to enter the main menu page, and select Advanced Settings - Switch On/Off - Switch Off. Make the inverter shut down safely.
2. Disconnect the AC circuit breaker connecting the inverter power grid port to the power grid.
3. Disconnect the AC breaker connecting the inverter load port to the emergency load.

4. Disconnect the PV side DC switch.
5. Turn off the battery and disconnect the DC switch between the battery and the inverter.
6. Wait for 5 minutes before checking the inverter.

- ▶ After using the menu setting to shut down the inverter, the inverter should be checked and reenergising, it still needs to be on the main menu page. Select advanced Settings - Switch On/Off- Switch On. start up to enable the inverter to start up and run.

### 8.1.2 Earth fault alarm

This inverter is compliant with IEC 62109-2 Clause 13.9 and AS/NZS 5033 for earth fault protection.

If an earth fault alarm occurs, the error is displayed on the LCD screen, the red light illuminates and the error can be found in the error history log.

When the inverter is connected to the battery system, when the battery system has ground fault/leak alarm in accordance with AS/NZS 5139, the inverter will also alarm. The alarm method is the same as above.

- ▶ In the case of devices equipped with a stick logger, the alarm information can be viewed on the monitoring portal and retrieved via the smartphone app.

## 8.2 Error list

### 8.2.1 Inverter error list

ID	Code Name	Description	Solution
001	GridOVP	The voltage of the power grid is too high	If the alarm occurs occasionally, the possible cause is that the electric grid is abnormal occasionally. Inverter will automatically return to normal operating status when the electric grid's back to normal.
002	GridUVP	The voltage of the mains is too low	
003	GridOFP	The mains frequency is too high	
004	GridUFP	The mains frequency is too low	If the alarm occurs frequently, check whether the grid voltage/frequency is within the acceptable range. If yes, please check the AC circuit breaker and AC wiring of the inverter. If the grid voltage/frequency is NOT within the acceptable range and AC wiring is correct, but the alarm occurs repeatedly, contact technical support to change the grid over-voltage, under-voltage, over-frequency, under-frequency protection points after obtaining approval from the local electrical grid operator.
005	GFCI	Charge Leakage Fault	Check for inverter and wiring.
008	IslandFault	Island protection fault	If the alarm occurs occasionally, the possible cause is that the electric grid is abnormal occasionally. Inverter will automatically return to normal operating status when the electric
009-010	GridOVPlnstant1/2	Transient overvoltage of mains voltage 1/2	

ID	Code Name	Description	Solution
011	VGridLineFault	Power grid line voltage error	<p>grid's back to normal.</p> <p>If the alarm occurs frequently, check whether the grid voltage/frequency is within the acceptable range. If yes, please check the AC circuit breaker and AC wiring of the inverter.</p> <p>If the grid voltage/frequency is NOT within the acceptable range and AC wiring is correct, but the alarm occurs repeatedly, contact technical support to change the grid over-voltage, under-voltage, over-frequency, under-frequency protection points after obtaining approval from the local electrical grid operator.</p>
012	InvVoltFault	Inverter overvoltage	<p>Internal faults of inverter, switch OFF inverter, wait for 5 minutes, then switch ON inverter. Check whether the problem is solved.</p> <p>If no, please contact technical support.</p>
013	RefluxFault	Feed-in Limit function is faulty	<p>Internal error of the inverter. Switch off the inverter, wait 5 minutes and then switch the unit on again.</p> <p>If the error persists, contact technical support.</p>
032	N-PE fault	Neutral ground fault	<p>Internal error of the inverter. Switch off the inverter, wait 5 minutes and then switch the unit on again.</p>
033	SpiCommFault (DC)	SPI communication is fault (DC)	<p>If the error persists, contact technical support.</p>

ID	Code Name	Description	Solution
034	SpiCommFault (AC)	SPI communication is fault (AC)	Internal faults of inverter. Switch OFF inverter, wait for 5 minutes, then switch ON inverter. Check whether the problem is solved. If no, please contact technical support.
038	InvSoftStartFail	Inverter failed to output	
039	ArcShutdownAlarm	Arc shutdown protection	
040	LowLightChkFail	Low light detection failed	
041	RelayFail	Relay detection failure	Internal error of the inverter. Switch off the inverter, wait 5 minutes and then switch the unit on again. If the error persists, contact technical support.
042	IsoFault	Insulation resistance is too low	Check the insulation resistance between the photovoltaic array and ground (ground), if there is a short circuit, the fault should be repaired in time.
043	PEConnectFault	Earth fault	Check the PE conductor for function
044	InputConfigError	Incorrect input mode configuration	Check the input mode (parallel/independent mode) Settings for the inverter. If not, change the input mode.
045	CTDisconnect	CT error	Check that the wiring of the current transformer is correct.
046	ReversalConnect	The PV is connected reversedly	Check whether the PV wiring is correct.

ID	Code Name	Description	Solution
047	ParallelFault	Master does not exist or is duplicate	Check the parallel mode settings for the inverter. Check whether the wiring is correct.
049	TempErrBat	Battery temperature error	For Inner BMS battery, make sure that the battery NTC cable is properly connected. Make sure the inverter is installed where there is no direct sunlight. Please ensure that the inverter is installed in a cool/ well-ventilated place. Ensure the inverter is installed vertically and the ambient temperature is below the inverter temperature limit.
050-055	TempErrHeatSink1-6	Temperature error heat sink 1-6	For AC inverter, make sure that the inverter NTC cable is properly connected. Make sure the inverter is installed where there is no direct sunlight or other heat source
057-058	TempErrEnv1/2	Temperature error ambient temperature 1/2	
059-061	TempErrInv1-3	Module 1-3 Temperature protection	
065	BusRmsUnbalance	Asymmetrical bus voltage RMS	Internal error of the inverter. Switch off the inverter, wait 5 minutes and then switch the unit on again. If the error persists, contact technical support.
066	BusInstUnbalance	The transient value of the bus voltage is unbalanced	

ID	Code Name	Description	Solution
067	BusUVP	The DC bus voltage is too low during mains connection	
068	BusZVP	The DC bus voltage is too low	
069	PVOVP	The PV input voltage is too high	Check whether the PV series voltage (Voc) is higher than the maximum input voltage of the inverter. If this is the case, adjust the number of PV modules in series. After the correction, the inverter automatically returns to its normal state.
070	BatOVP	Battery overvoltage	Check whether the voltage of the battery is higher than the maximum input voltage of the inverter. If this is the case, adjust the number of battery modules in series.
071	LLCBusOVP	LLC Bus overvoltage protection	
072	SwBusRmsOVP	Inverter bus voltage RMS Software overvoltage	Internal error of the inverter. Switch off the inverter, wait 5 minutes and then switch the unit on again.
073	SwBusOVP	Inverter bus voltage instantaneous Software overvoltage	If the error persists, contact technical support. Internal error of the inverter. Switch off the inverter, wait 5 minutes and then switch the unit on again.

ID	Code Name	Description	Solution
081	SwBatOCP	Software overcurrent protection of the battery	<p>If the error persists, contact technical support.</p> <p>Internal error of the inverter. Switch off the inverter, wait 5 minutes and then switch the unit on again.</p> <p>If the error persists, contact technical support.</p>
082	DciOCP	Dci overcurrent protection	
083	SwIOCP	Instantaneous output current protection	
085	SwAcRmsOCP	Output RMS current protection	
086	SwPvOCPInstant	PV overcurrent software protection	
087	IpvUnbalance	PV flows in uneven parallelism	
088	IacUnbalance	Unbalanced output current	
089	SwPvOCP	PV software overcurrent protection	
090	IbalanceOCP	Balanced current protection	
096	EPSLoadShortCircuit	Inverter bus hardware overvoltage	
098	HwBusOVP	Inverter bus hardware overvoltage	<p>Internal error of the inverter. Switch off the inverter, wait 5 minutes and then switch the unit on again.</p>

ID	Code Name	Description	Solution
100	HwBatOCP	Battery hardware overflow	If the error persists, contact technical support.
102	HwPVOCP	PV hardware overflows	Internal error of the inverter. Switch off the inverter, wait 5 minutes and then switch the unit on again.
103	HwACOCP	Mains current is too high and has triggered hardware protection	If the error persists, contact technical support.
105	MeterCommFault	Communication fault with meter unit	Check whether the meter is connected correctly.
110-112	Overload1-3	Overload protection 1-3	Please check whether the inverter is operating under overload.
113	OverTempDerating	The inverter has throttled due to too high a temperature	Make sure that the inverter has been installed in a cool and well-ventilated place without direct sunlight. Make sure the inverter is installed vertically and the ambient temperature is below the temperature limit of the inverter.
114	FreqDerating	AC frequency is too high	Make sure that the mains frequency and voltage are within the permissible range.
124	BatDchgProhibit	The battery is low	Please check if the battery soc of the inverter is too low.
125	BatLowVoltShut	No battery protection	Please check if the battery voltage of the inverter is too low.

ID	Code Name	Description	Solution
128	BatReversalConnect	The battery is connected reversedly	Check whether the battery wiring is correct.
129	PermHwAcOPP	Mains current is too high and has caused an unrecoverable hardware fault	Internal error of the inverter. Switch off the inverter, wait 5 minutes and then switch the unit on again. If the error persists, contact technical support.
145	USBFault	Device cannot read data from USB stick.The USB stick has been damaged. Or the format of the USB stick is not compatible with the device.	Switch off the inverter, wait 5 minutes and then switch the unit on again.If the error persists, contact technical support.
147	BluetoothFault	The device's Bluetooth communication has failed	Switch off the inverter, wait 5 minutes and then switch the unit on again.If the error persists, contact technical support.
151	BatPartOffline	A portion of the battery's communication is lost	Switch off the inverter, wait 5 minutes and then switch the unit on again.If the error persists, check the communication line or the connection of the battery and the inverter for errors.

ID	Code Name	Description	Solution
152	SafetyVerFault	The safety version is inconsistent with the internal safety version	Check whether safety regulations comply with local standards and import correct safety parameters.
153	SCILose(DC)	SCI communication error (DC)	Upgrade software
154	SCILose(AC)	SCI communication error (AC)	Upgrade software
156	SoftVerError	Inconsistent software versions	Download the latest firmware from the website and launch the software update. If the error persists, contact technical support.
157-158	BMS1-2CommFault	Lithium battery 1-2communication error	Make sure your battery is compatible with the inverter. CAN communication is recommended. Check the communication line or the connection of the battery and the inverter for errors.
162	RemoteShutdown	Remote shutdown	The inverter is shut down remotely.
163	Drms0Shutdown	DRM 0 shutdown	The inverter is running with a Drms0 shutdown.
177	BMS OVP	BMS overvoltage alarm	Internal error in the connected lithium battery. Switch off the inverter and the lithium battery, wait 5 minutes and then switch the components on again.
178	BMS UVP	BMS Undervoltage alarm	

ID	Code Name	Description	Solution
179	BMS OTP	BMS High temperature warning	If the error persists, contact technical support.
180	BMS UTP	BMS low temperature warning	
181	BMS OCP	BMS overload warning during charging and discharging	
182	BMS Short	BMS Short circuit alarm	Please contact technical support.
185	BMS CAN VerLow	Inconsistent software versions	Download the latest firmware from the website and launch the software update. If the error persists, contact technical support.
186	BatDischargeHTP	BAT High temperature warning when discharging.	Internal error in the connected lithium battery. Switch off the inverter and the lithium battery, wait 5 minutes and then switch the components on again. If the error persists, contact technical support.
187	BatDischargeLTP	BAT low temperature warning when discharging.	
188	BatChargeHTP	BAT High temperature warning when charging.	

ID	Code Name	Description	Solution
189	AFCICommLosse	AFCI communication error	Please ensure proper installation of the AFCI breaker.
190	BatChargeLTP	BAT low temperature warning when charging.	Internal error in the connected lithium battery. Switch off the inverter and the lithium battery, wait 5 minutes and then switch the components on again. If the error persists, contact technical support.
328	AcStartTimeOut	BAT active failed.	Internal error in active lithium battery. Check the power line and CAN line between inverter and battery, and then try again. If the error persists, please contact technical support
379	AFCICheckError	AFCI chip self-test abnormality	Switch off the inverter, wait 5 minutes and then switch the unit on again. If the error persists, contact technical support.
401	AFCIO	Arcing detected in AFCI channel	

### 8.2.2 Battery error list

ID	Name	Description	Solution
808	HSIHighTempWarning	Radiator 1 high temperature alarm	Check whether the number of batteries is set correctly. If the setting is correct, please contact technical support to upgrade software.
809	EnvHighTempWarning	Ambient high temperature alarm	Please make sure the battery is installed in a cool well-ventilated place.

ID	Name	Description	Solution
813	StopChgWarning	Charging prohibition alarm	If the battery is almost fully, no action is required. Otherwise, please contact technical support.
814	StopDchgWarning	Discharging prohibition alarm	If the battery is almost empty, no action is required. Otherwise, please contact technical support.
864	HSIOverTempFault	Over temperature protection of radiator 1	Power off and wait for 2 hours. If the problem is not solved, please contact technical support.
865	OverTempFault_Env	Over temperature protection of ambient temperature	
866	SciCommFault	Internal communication failure of battery	If this fault occurs occasionally, wait a few minutes to see whether the problem is solved. If this fault occurs frequently, please contact technical support.
867	Can1CommFault	Can1 communication failure	If this fault occurs occasionally, wait a few minutes to see whether the problem is solved. If this fault occurs frequently, please contact technical support.
872	SwBusInstantOVP	Bus software overvoltage	If this fault occurs occasionally, wait a few minutes to see whether the problem is solved. If this fault occurs frequently, please contact technical support.
873	SwBusInstantUVP	Bus software undervoltage	
874	SwBatInstantOVP	Battery software overvoltage	
875	SwBatInstantUVP	Battery software undervoltage	
879	HwOCP	Hardware overcurrent	
880	unrecoverBusAvgOV	Permanent bus overvoltage	Restart the battery and wait for minutes. If the problem is not resolved, please contact technical support.
883	unrecoverHwOCP	Permanent hardware overcurrent	

ID	Name	Description	Solution
893	unrecoverBusSCP	Permanent short-circuit protection	Restart the battery and wait for minutes. If the problem is not resolved, please contact technical support.
894	unrecoverBatActFail	Permanent battery activation failed	
895	unrecoverBusRPP	Permanent bus reverse connection	Check whether the wiring is correct and restart the battery. If the problem is not resolved, please contact technical support.
899	BMSOVOC P	BMS overvoltage and overcurrent fault	If this fault occurs occasionally, wait a few minutes to see whether the problem is solved. If this fault occurs frequently, please contact technical support.
900	SwBatAvg OCP	Battery average overcurrent protection	
901	SwAvgOver loadP	Average overload protection	
902	SwBusInstantOCP	Bus software overcurrent	
903	SwCBCOCP	Software CBC overcurrent protection	
905	StartupBus SCP	Start up short circuit protection	Restart the battery and wait for minutes, Check if the power line is short circuited ,If the problem is not resolved, please contact technical support.
906	SwBusAvg UVP	Bus average undervoltage	Restart the battery and wait for minutes. If the problem is not resolved, please contact technical support.
907	ChipClockFault	Clock failure of the chip	Restart the battery and wait for minutes. If the problem is not resolved, please contact technical support.
908	PCScanCommunicationFault	Faulty CAN communication between battery and inverter	Make sure your battery is compatible with the inverter. CAN communication is recommended. Check the communication line or the connection of the battery and the inverter for errors.

ID	Name	Description	Solution
909	HeatsinkLowTempFault	Heatsink low temperature fault	Please make sure that the heatsink temperature is not lower than the temperature limit of the battery.
910	EnyLowTempFault	Low ambient temperature, battery failure	Please make sure that the ambient temperature is not lower than the temperature limit of the battery.
911	ADOffsetCalibrateFault	Sample Offset Calibration Failure	Restart the battery and wait for minutes. If the problem is not resolved, please contact technical support.

## 8.3 Maintenance

Inverters do not generally require daily or routine maintenance. Before carrying out cleaning, ensure that the DC switch and AC circuit breaker between the inverter and power grid have been switched off. Wait at least 5 minutes before carrying out cleaning.

### 8.3.1 Cleaning the inverter

Clean the inverter using an air blower and a dry, soft cloth or a soft bristle brush. Don't clean the inverter with water, corrosive chemicals, cleaning agents etc.

### 8.3.2 Cleaning the heat sink

In order to help guarantee correct long-term operation of the inverter, make sure that there is sufficient space for ventilation around the heat sink. Check the heat sink for blockages (dust, snow etc.) and remove them if present. Please clean the heat sink using an air blower and a dry, soft cloth or a soft bristle brush. Do NOT clean the heat sink with water, corrosive chemicals, cleaning agents etc.

## 9 Datasheet

- The following parameters may change without notice, please refer to the user manual and Datasheet on our website.

Model	ESI-5K-T1	ESI-6.5K-T1	ESI-8K-T1	ESI-9.9K-T1-A	ESI-10K-T1	ESI-12K-T1
<b>PV Input</b>						
Recommended Max. PV Power	10 kWp	13kWp	16 kWp	20 kWp	20 kWp	24 kWp
Max. Input Voltage	1000 Vd.c.					
Start-up Voltage[1]	200 Vd.c.					
Rated Input Voltage	600 Vd.c.					
MPP Voltage Range	160-950 Vd.c.					
Number of MPPT	3					
Max. Number of Input Strings per MPPT	1/1/1					
Max. Input Current	20/20/20 A					
Max. Isc	25/25/25 A					
<b>Battery</b>						
Voltage Range	350-435 Vd.c.					
Number of Battery Input Channels	1					
Max. Charging Power[3]	10 kW					
Max. Discharging Power	5 kW	6.5 kW	8 kW	9.9 kW	10 kW	10 kW
Max. Charging Current	25 A					
Max. Discharging Current	15 A	19.5	24 A	29.7 A	30 A	30 A
Battery Type[2]	Lithium-ion					
BMS Communication	CAN					
<b>AC Backup</b>						
Rated Output Voltage	3N~+PE,380/400/415 Va.c.					
Rated Output Frequency	50/60 Hz					
Rated Output Power	5 kW	6.5 kW	8 kW	9.9 kW	10 kW	12 kW
Rated Output Current	7.6/7.2/6.9 A	9.9/9.4/9.0 A	12.1/11.6/11.1 A	15.0/14.3/13.8 A	15.2/14.5/13.9 A	18.2/17.4/16.7 A
Rated Apparent Power	5 kVA	6.5 kVA	8 kVA	9.9 kVA	10 kVA	12 kVA
Max. Apparent Power	5.5 kVA	7.15 kVA	8.8 kVA	9.9 kVA	11 kVA	13.2 kVA
Max. Output Current	8.3/8.0/7.6 A	10.9/10.3/9.9 A	13.3/12.8/12.2 A	15.0/14.3/13.8 A	16.7/15.9/15.3 A	20.0/19.1/18.3 A

Model	ESI-5K-TI	ESI-6.5K-TI	ESI-8K-TI	ESI-9.9K-TI-A	ESI-10K-TI	ESI-12K-TI
Peak Output Apparent Power[3]	2 times of rated power, 10s					
THDv(@ linear load)	<3%					
Switching Time	10 ms default					
Asymmetric load	Yes, Supports 100% three-phase unbalanced load					
AC Grid						
Rated Voltage	3(N)--+PE,380/400/415 Va.c.					
Rated Frequency	50/60 Hz					
Rated Output Power	5 kW	6.5 kW	8 kW	9.9 kW	10 kW	12 kW
Rated Output Current	7.6/7.2/6.9 A	9.9/9.4/9.0 A	12.1/11.6/11.1 A	15.0/14.3/13.8 A	15.2/14.5/13.9 A	18.2/17.4/16.7 A
Rated Apparent Power	5 kVA	6.5 kVA	8 kVA	9.9 kVA	10 kVA	12 kVA
Max. Apparent Power	5.5 kVA	7.15 kVA	8.8 kVA	9.9 kVA	11 kVA	13.2 kVA
Max. Output Current	8.3/8.0/7.6 A	10.9/10.3/9.9 A	13.3/12.8/12.2 A	15.0/14.3/13.8 A	16.7/15.9/15.3 A	20.0/19.1/18.3 A
Max. Input Current	15.2/14.5/13.9 A	19.8/18.8/18.1 A	24.2/23.2/22.2 A	30.3/29.0/27.8 A	30.3/29.0/27.8 A	33.3/31.9/30.6 A
THDi	<3%					
Power Factor Range	0.8 lagging-0.8 leading					
Efficiency						
Max. MPPT Efficiency	99.9%					
Max. Efficiency	98.0%	98.0%	98.0%	98.2%	98.2%	98.2%
European Efficiency	97.0%	97.0%	97.0%	97.5%	97.5%	97.5%
Max. Efficiency of Charging/Discharging[4]	97.6%	97.6%	97.6%	97.8%	97.8%	97.8%
Protection						
DC Switch	Yes					
PV Reverse Connection Protection	Yes					
Battery Reverse Connection Protection	Yes					
Output Short Circuit Protection	Yes					
Output Overcurrent Protection	Yes					
Output Overvoltage Protection	Yes					
Insulation Impedance Detection	Yes					
Residual Current Detection	Yes					
Anti-island Protection	Yes					
Surge Protection[5]	PV:Type II, AC:Type II					

Model	ESI-5K-T1	ESI-6.5K-T1	ESI-8K-T1	ESI-9.9K-T1-A	ESI-10K-T1	ESI-12K-T1
General Parameter						
Inverter Topology	Non-Isolation					
Protective Class	Class I					
IP Rating	IP66					
Oversvoltage Category	AC III, DC II					
Operating Temperature Range	-30°C to +60°C (derating above +45°C)					
Relative Humidity Range	5%-95%					
Max. Operating Altitude	4000 m (derating above 2000 m)					
Standby Self-consumption[6]	<10 W					
Installation Method	Wall Mounted					
Dimensions(W*H*D)	708*440*170 mm					
Cooling Mode	Natural					
Weight	30 kg					
Communication	RS485,Optional:WiFi/4G/LAN					
Display	LCD & APP					

[1] Minimum PV voltage to start MPPT operation.

[2] Please refer to document “SOFAR inverter Model compatible battery list”.

[3] Full battery and sun.

[4] Battery-AC maximum efficiency of battery charge and discharge.

[5] According to EN/IEC 61643-11.

[6] Standby loss at rated input voltage.

Version 1.0



ENERGY TO POWER YOUR LIFE

**ADDRESS**

11th Floor, Gaoxingqi Technology Building,  
District 67, Xingdong Community, Xin'an Street,  
Bao'an District, Shenzhen, China

**EMAIL**

[info@sofarsolar.com](mailto:info@sofarsolar.com)

**WEBSITE**

[www.sofarsolar.com](http://www.sofarsolar.com)

[SOFARSOLAR](#) 

