



Designed for Canada

Ascent 1.1

short side clamping

Code-Compliant Planning and Installation Guide
Complying with NBCC 2020



Introduction

Clenergy PVezRack® Ascent 1.1 is a low ballast, south/north, east-west facing solution for PV installation on flat roofs. With a special design and a maximum tilt angle of 10° and 15°, Ascent 1.1 is suitable for pv module clamping from both long side and short side.

This installation manual must be read carefully prior carrying any installation. This manual provides the following content:

- (1) Supporting documentation for building permit applications relating to PV-ezRack Ascent 1.1 PV Module Mounting System,
- (2) Planning and installation instructions.

List of contents

Introduction	1
Tools & Component list	3
System Overview	4
Installation Instructions	7

Structural integrity of the PVezRack® Ascent 1.1 parts will be compliant with the NBCC 2020 standard when installed correctly. Make sure to comply with the relevant Occupational Health and Safety regulations when carrying any installation. Also, make sure to comply with other relevant State or Federal regulations.

Always check you are using the latest version of this Installation manual. To do that, contact your local distributor or contact Clenergy via the following email: sales@clenergy.com otherwise.

The installer is solely responsible for:

- Complying with all applicable local or national building codes, including any that may supersede this manual;
- Ensuring that PV-ezRack and other products are appropriate for the particular installation and the installation environment;
- Using only PV-ezRack parts and installer-supplied parts as specified by the PV-ezRack project plan. (substitution of parts may void the warranty and invalidate the letter of certification);
- Recycling: Recycle: according to the local relative statute.
- Removal: Reverse installation process.
- Ensure that there are no less than two professionals working on panel installation.
- Ensure the installation of related electrical equipment is performed by qualified personnel.
- Ensuring safe installation of all electrical aspects of the PV array.this includes adequate earth bonding of the PV array and PVezRack® components as required in CSA C22.1:21
- Ensuring that the roof, its rafters/purlins, connections, and other structural support members can support the array under building live load conditions;
- Ensuring that screws to fix interfaces have adequate pull-out strength and shear capacities as installed;
- Maintaining the waterproof integrity of the roof, including selection of appropriate flashing;

Product Warranty:

Please refer [PVezRack® Product Warranty](#) on our website.

Planning & Design

The Ascent 1.1 flat roof system is designed to be used on flat roofs with a roof inclination of up to 5 degrees. The system uses ballast weight (paving slabs or similar) to withstand wind loads and stabilise the system. The required amount of ballast depends on the wind load which is specific to the location, building height roof area, system layout and roof surface. For support or requests for ballast calculations please contact sales@clenergy.com.

The friction coefficient value used in the ballast calculation must be determined on site with both wet and dry tests. Please refer to the Clenergy guidance note friction coefficient test.

For Ascent 1.1 installations clamping on the short side / corner clamping of the module it is important that the maximum permissible loads of the module manufacturer and clamping positions are checked.

Before installation of the PV system, it is important that the roof area is free of dirt, snow and ice. Clarification that the PV system does not impede the roofs' ability to drain rainwater. It should be clarified before any installation of a project that the roof structure can take the additional weight and loads of the PV system, ballast and the effects of wind and snow. It is important that the correct building protection matt is specified for the roof covering.

Consideration should be given to the position of the PV array. Wind loads are much higher in edge and corners zones. It is good practice to keep a minimum distance of 600-1200mm away from these roof areas. Planning of suitable maintenance gaps / walkways should be applied to the design to access the PV system for any maintenance works in the future. Special attention needs to be given to any LPS (lightning protection System) on the building and guidance should be taken from a professional and the relevant National and international guidance notes regarding separation distances between the PV system and the building LPS.

Wind Load Assessment

Guidelines for the calculation of ballast can be taken from NBCC 2020.

Suction and pressure coefficients have been determined through wind tunnel testing at the IFI Institute.

Application

Roof pitch: maximum 5°.

Maximum solar panel dimensions (listed in page 6):

-When using 1500 and 2450mm base rail: length 2000mm, width 1190mm, height 28-40mm.

-When using 2240mm base rail: length 2000mm, width 1134mm, height 28-40mm.

Array set up: maximum length 23m, maximum width 20m, please also keep at least 20mm gap between arrays.

Note: It is recommended to acquire PV modules clamping info. from PV modules manufacturer if the panel dimensions exceed 1762 mm x 1134 mm.

Design Standards:





- NBC 2020
- OBC 2012/2022 & OBC 2024
- BCBC 2018 & BCBC 2024
- NBC(AE) 2019 & NBC(AE) 2023
- NBC 2010 (Manitoba Amendments)
- CAN/CSA S157-17
- CAN/CSA S16-14 (R2019)

Ongoing maintenance O&M









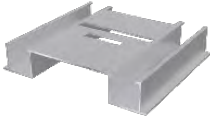

There should be regular system of maintenance for all PV systems. It is good practice to have a sufficient annual maintenance schedule to check the condition of the PV system, and check for any loose connections or movement of a system and that the ballast blocks are stable, this is particularly relevant in the event of abnormal weather conditions such as a storm or excessive high winds.

Tools and Components

Tools

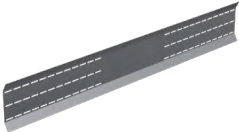
				
Screw Driver	Drive Bit	Torque Spanner	Tape	String & Marker Pen

Components

				
FL-ACV11/G/10 FL-ACV11/G/15 Front Leg 10°/15°	RL-ACV11/G/10 Rear Leg 10°	RL-ACV11/G/15 Rear Leg 15°	SEB-ACV11/100 Start and End Base, Length 100mm	CB-ACV11/EW/200 CB-ACV11/EW/250 Connection Base, length 200 and 250mm
				
MB-ACV11/EW/ XXXX Main Base East-west, length 2450 and 2240mm	MB-ACV11/SN/XXXX Main Base, North/south	WD-ACV11/10/ XXXXM Wind Deflector	BB-ACV11/Z/XXXXM Z-Shaped Ballast Bar	EZ-PM-AC Protection Mat
				
EZ-PM-AC/RB Protection Mat with EPDM	EZ-GL-U/12 Rialto Grounding Lug, with 12mm U-opening			

System Overview

Overview of PVezRack Ascent 1.1 short side clamping (take 10° as an example)

- North/South Facing



- ① Start and End Base L100 ② Front Leg 10° ③ Main Base, north/south ④ Rear Leg 10° ⑤ Wind Deflector
- ⑥ Protection Mat

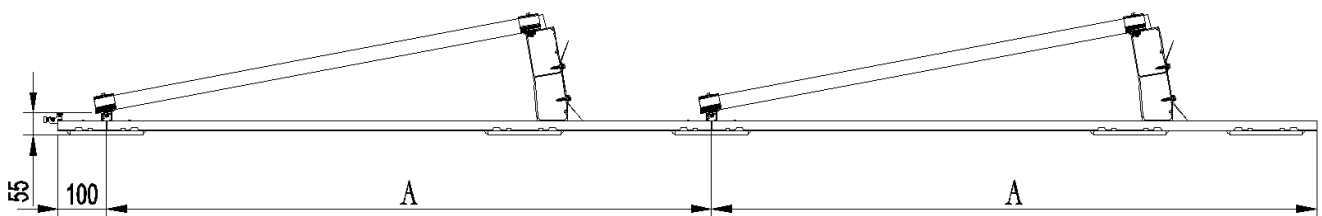

Notes:

Please find detailed Row Spacing at table below.

- East-west Facing

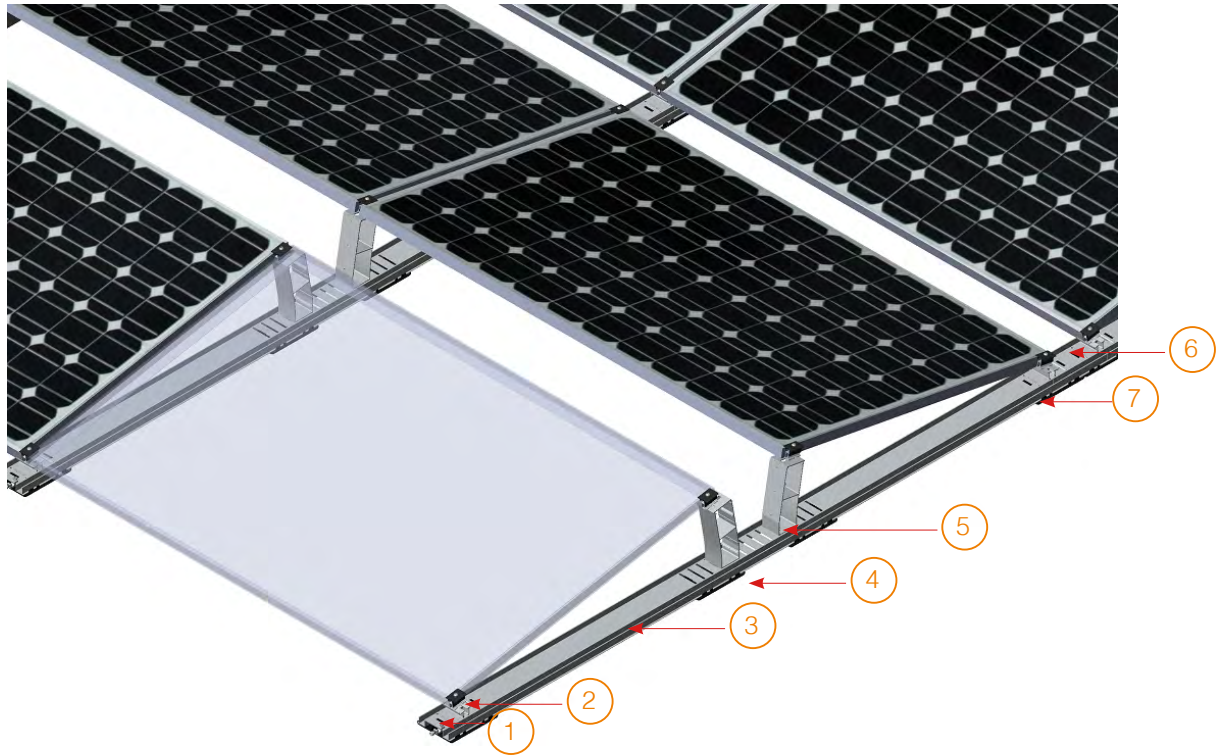

- ① Start and End Base L100 ② Front Leg 10° ③ Main Base, East-west ④ Ballast Bar ⑤ Rear Leg 10°
- ⑥ Connection Base ⑦ Protection Mat

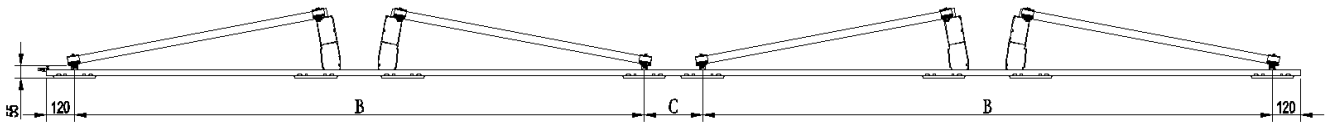

Row Spacing (mm)		
A	B	C
1500	2240	200/250
	2450	200/250

Determine the mounting hole of Main Base

There are 8 mounting holes in main base and marked with numbers. Please refer to the table below to identify the correct hole based on the module dimensions.

Setting Angle/°	Module Width (mm)		Actual Angle/°	Mounting Hole Selection		
	Min.	Max.		South/north	East-west	
				1500mm Base	2450mm Base	2240mm Base
10	1018	1052	11.8	1	1	4
	1053	1086	11.4	2	2	5
	1087	1120	11.0	3	3	6
	1121	1134	*	4	4	6
	1135	1155	10.7	4	4	Not available
	1156	1190	10.3	5	5	Not available
15	1018	1052	17.1	1	1	4
	1053	1086	16.5	2	2	5
	1087	1120	16.0	3	3	6
	1121	1134	**	4	4	6
	1135	1155	15.5	4	4	Not available
	1156	1190	15.0	5	5	Not available

* When using 1500 and 2450mm base, the actual angle should be 10.7°, 2240mm base should be 11.0°.

** When using 1500 and 2450mm base, the actual angle should be 15.5°, 2240mm base should be 16.0°.

Installation Instruction

Take East-west facing solution as an example.

Base Installation

Mark system start point of the Base and lay out the Start and End Base, Front Leg, Main Base according to the planning documents.

Please lay out all components from East to West direction.

The sequence is the same in each row and always ends with Start and End Base.

Connect the Base with the Front Leg using the method shown in the right figures. Place the Base to roof after installation is done.

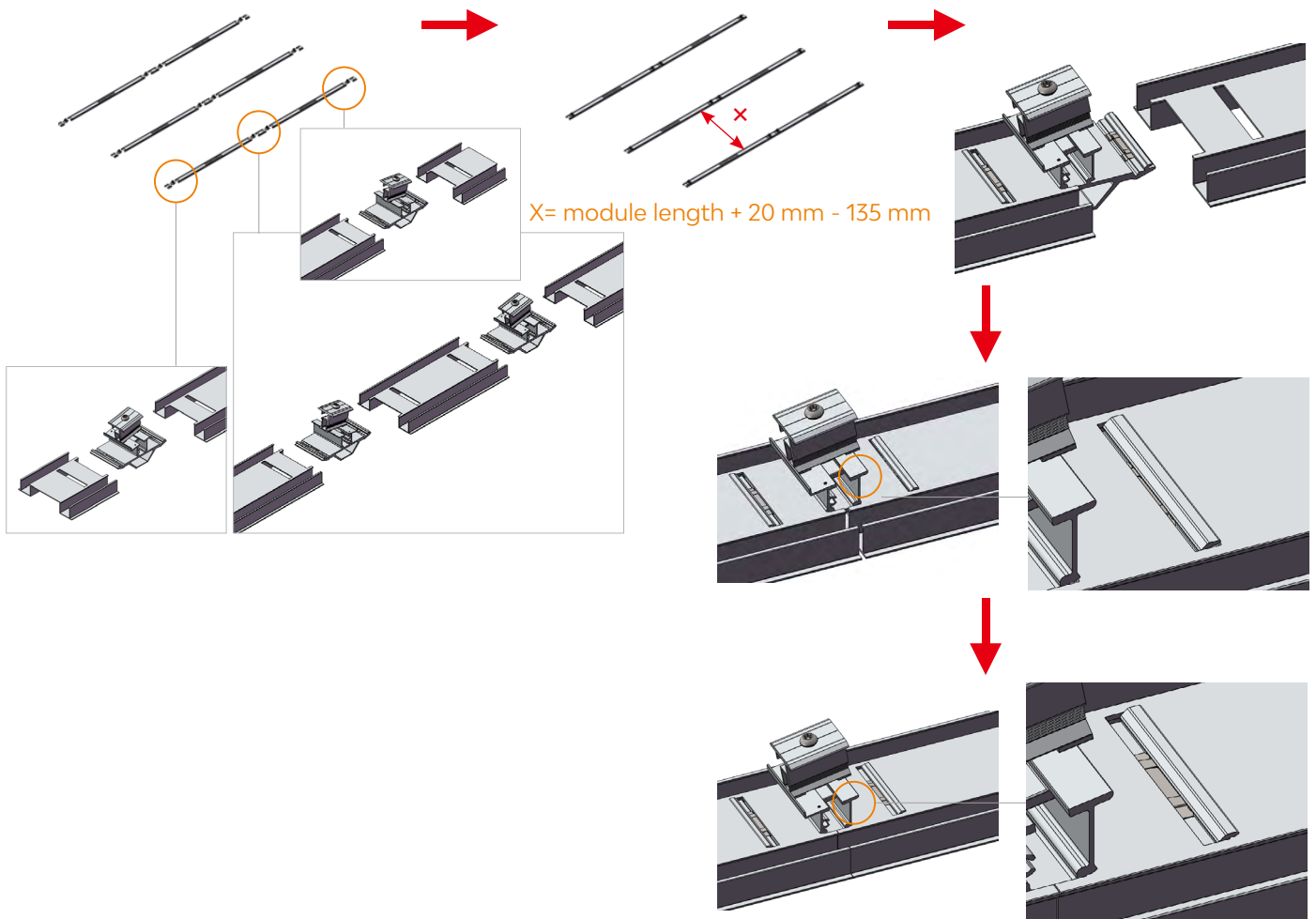

Protection Mat Installation

Install Protection Mat under Base where Front Leg and Rear Leg are installed.



Protection Mat under Front Leg

Press the Base down to securely fit into Protection Mat shown in the right figures.

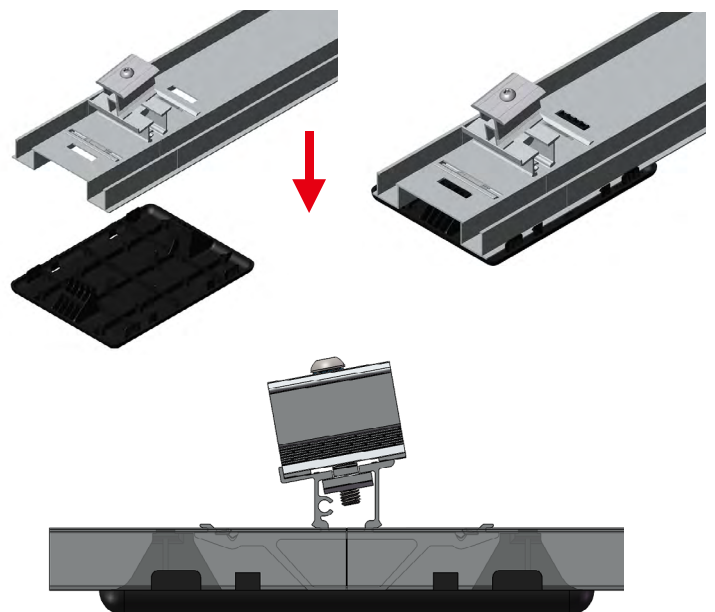

Protection Mat under Rear Leg

Press the Base down to securely fit into Protection Mat.

Slide Protection Mat to fit into the hole in the base until you hear a clicking sound.

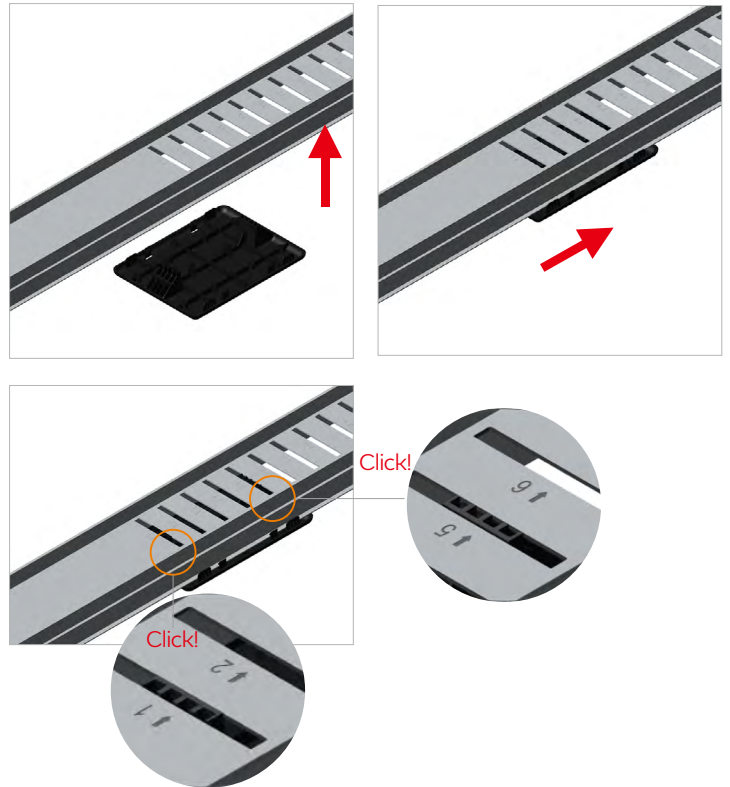

Notes:

Attention to the installation position of Rear Leg which is selected in Page 6:

When the Rear Leg are installed in odd-numbered holes (1, 3 or 5), the Protective mat should be installed into holes 2 and 6;

When the Rear Leg are installed in even-numbered holes (2, 4 or 6), the Protective mat should be installed into holes 1 and 5.

Illustration of Protective Mat & Rear Leg Placement:

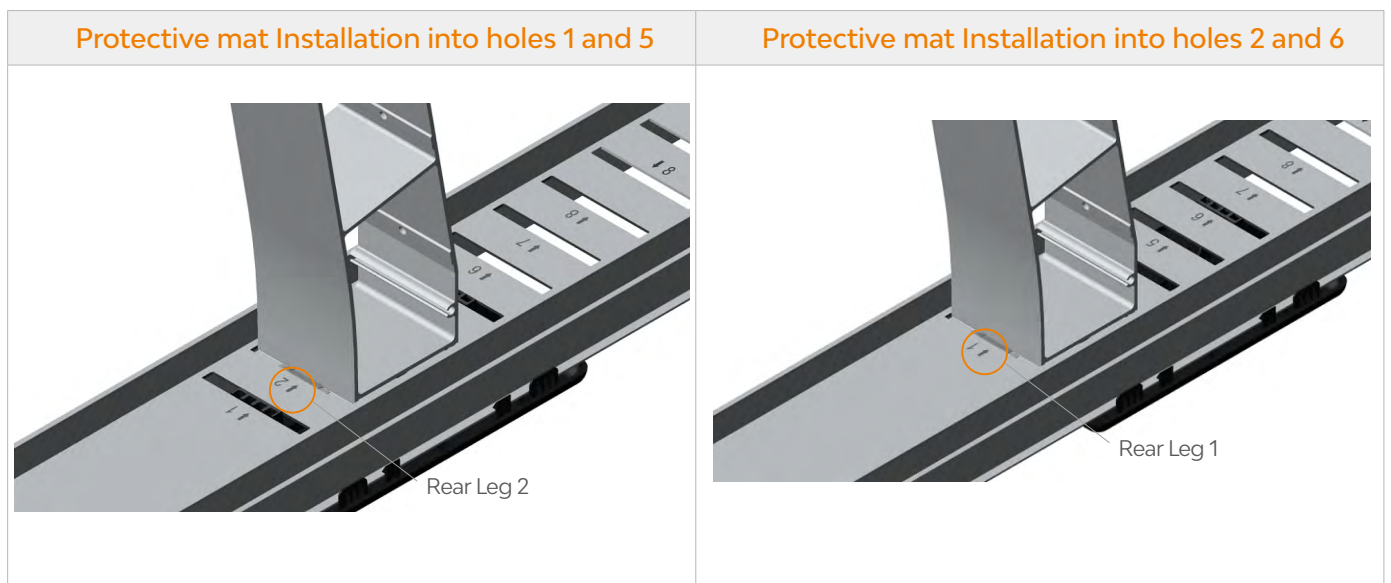

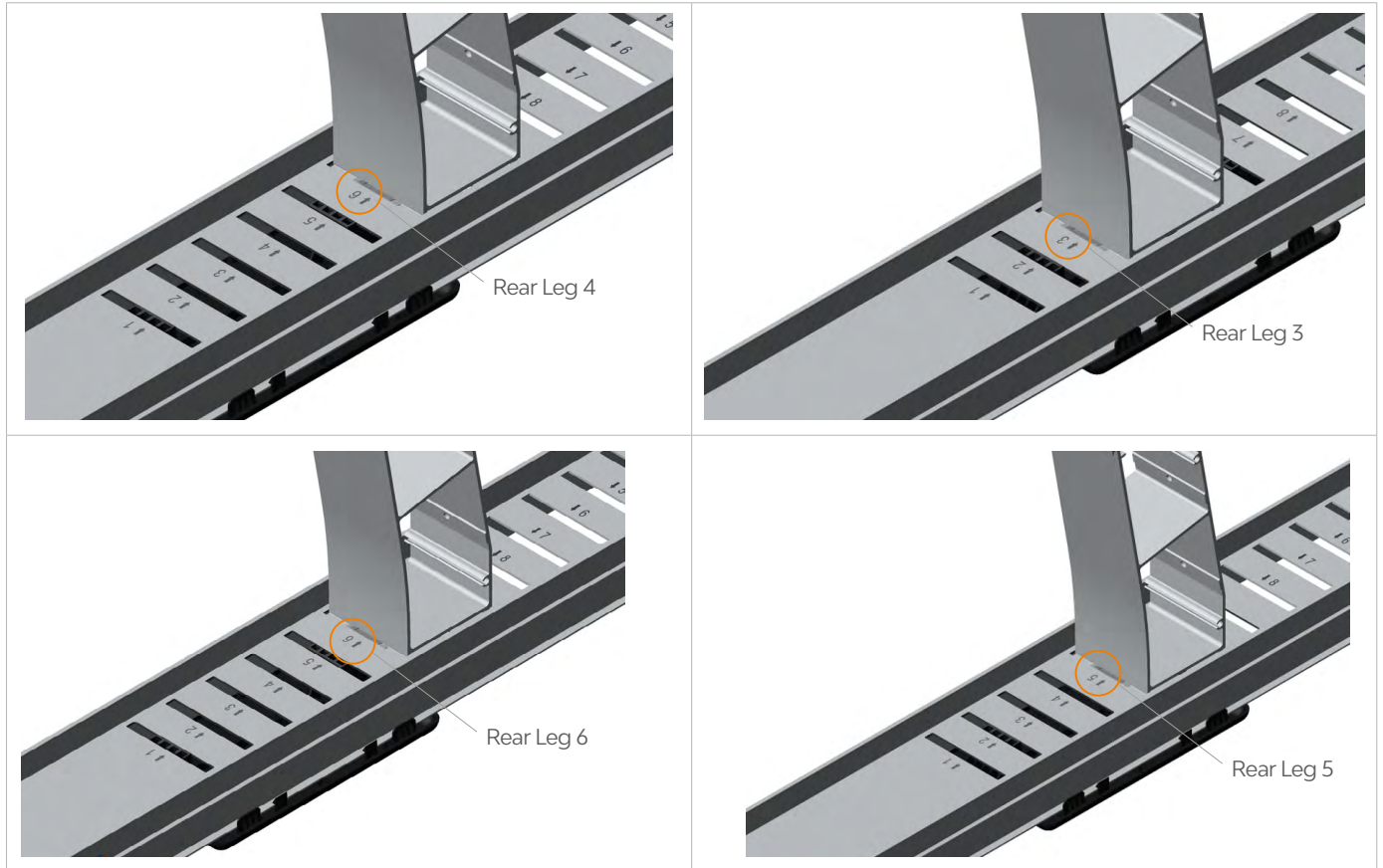

Rear Leg Installation

Install the Rear Leg to the Base using the method shown in below figures.

Notes:

Please refer to page 6 to identify the correct mounting hole based on the module dimensions.

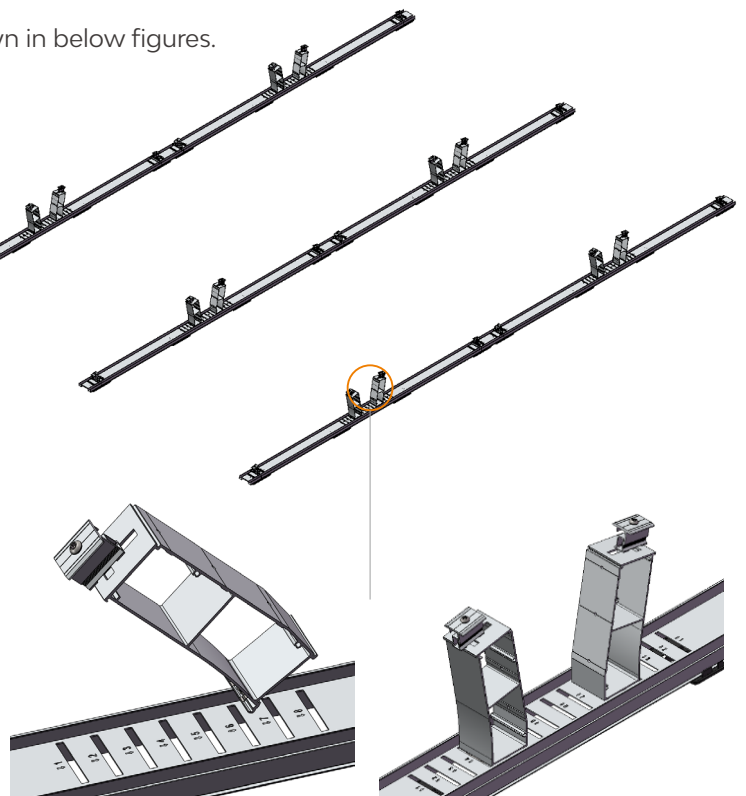

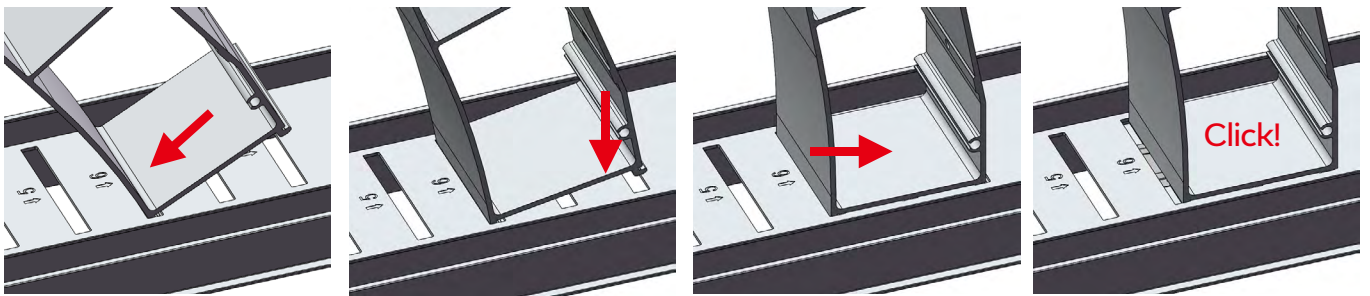
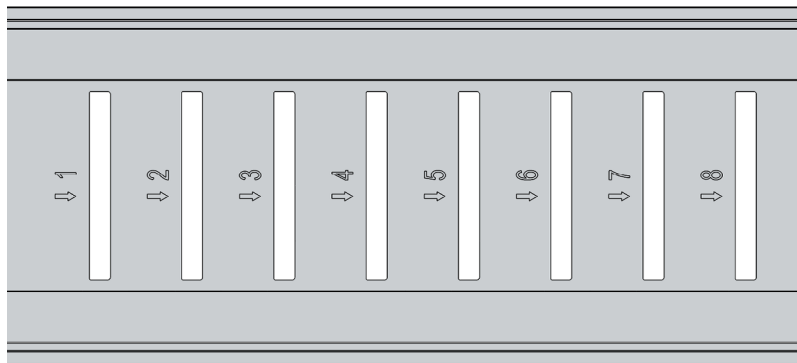

Ballast Placement

There are two different ways to place ballast blocks.

Opinion 1: On Base

Place the ballast blocks centrally on the Base.

Note:

please place the ballast blocks under the modules first if the space is enough.

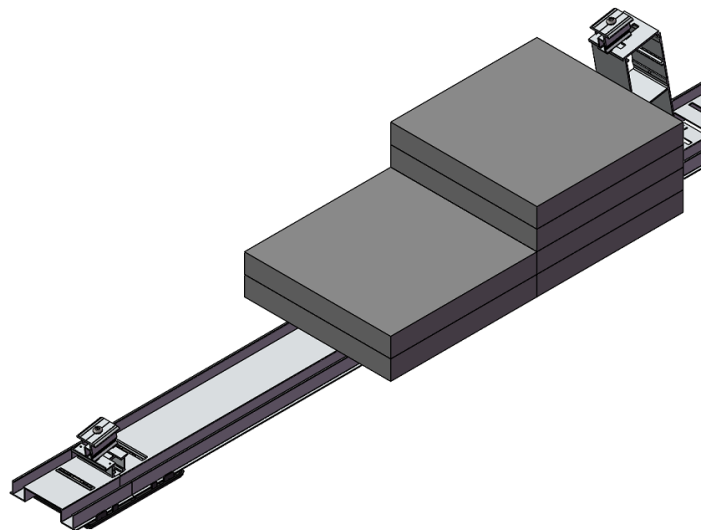

Opinion 2: On Ballast Bar

Place the ballast blocks centrally on Ballast Bar and fasten with 4 sets of T-head bolt and nut with a torque of 10 N.m.

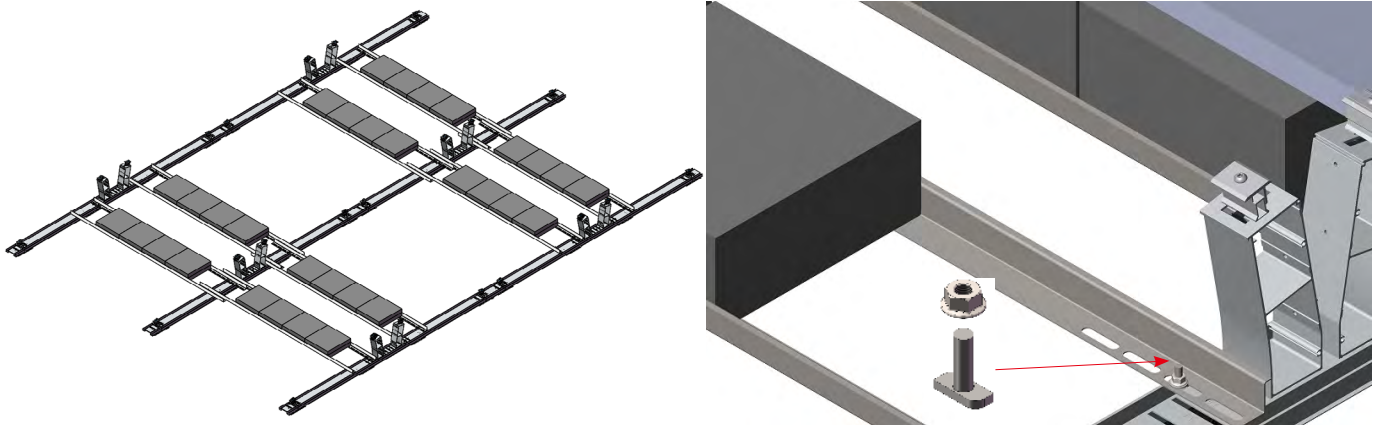

PV Module Installation

Put the module on the Front Leg and Rear Leg. Leave an approx. 20 mm gap.

Tighten the hexagon socket screw with a torque of 14 N.m.

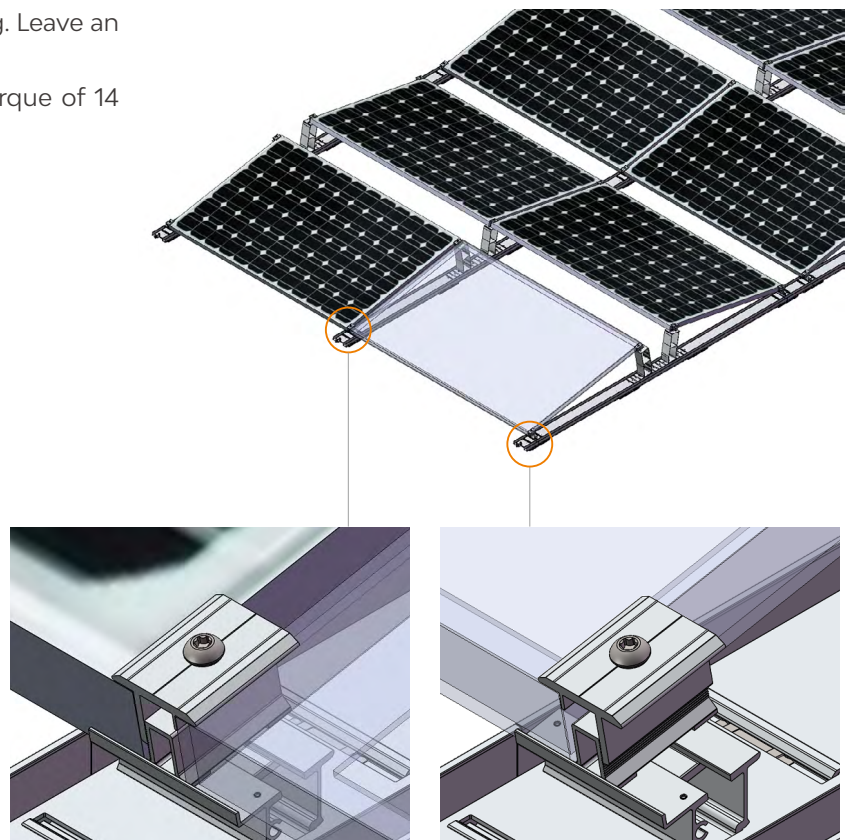

Grounding Lug Installation

It is required to install one Grounding Lug per row of base.
 The recommended torque of the bolt M6*14 is 4 N·m.
 Fix the Grounding lug on the end of base. Make sure the inner face of side opening of Grounding lug is closely attach to the base as shown in right figure. Strip earthing cable if needed, insert the conductor into the Grounding lugs.
 Recommended Torque is 5-6 N·m

Note:

Please Keep the cable size between 6-12mm.

Please install on the side of ballast base, as shown in the right figures, which can reduce the rotation of the grounding lug after tightening.

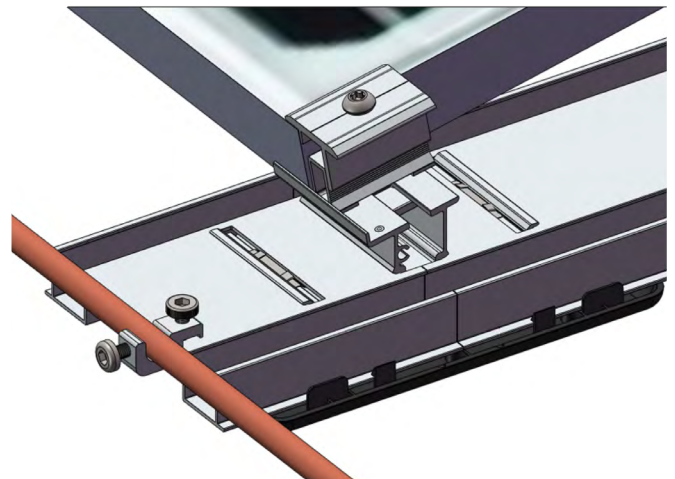
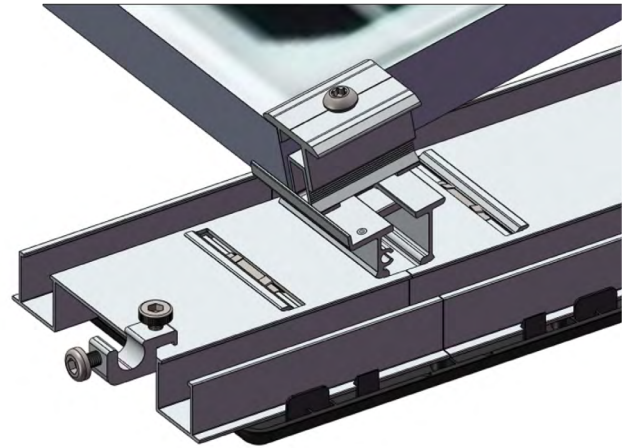







PV-ezRACK®

Clenergy

3/10 Duerdin St
Clayton VIC 3168
Australia

Phone: +61 3 9239 8088
Email: sales@clenergy.com.au
Web: www.clenergy.com.au

 @ClenergyGlobal / @ClenergyClub / ClenergyAUS  @Clenergy  @ClenergyClub
 @Clenergy_global  @Clenergy

A Clenergy Technologies Company