



SMA eCharger

Legal Provisions

The information contained in these documents is the property of SMA Solar Technology AG. No part of this document may be reproduced, stored in a retrieval system, or transmitted, in any form or by any means, be it electronic, mechanical, photographic, magnetic or otherwise, without the prior written permission of SMA Solar Technology AG. Internal reproduction used solely for the purpose of product evaluation or other proper use is allowed and does not require prior approval.

SMA Solar Technology AG makes no representations or warranties, express or implied, with respect to this documentation or any of the equipment and/or software it may describe, including (with no limitation) any implied warranties of utility, merchantability, or fitness for any particular purpose. All such representations or warranties are expressly disclaimed. Neither SMA Solar Technology AG nor its distributors or dealers shall be liable for any indirect, incidental, or consequential damages under any circumstances.

The exclusion of implied warranties may not apply in all cases under some statutes, and thus the above exclusion may not apply.

Specifications are subject to change without notice. Every attempt has been made to make this document complete, accurate and up-to-date. Readers are cautioned, however, that product improvements and field usage experience may cause SMA Solar Technology AG to make changes to these specifications without advance notice or per contract provisions. SMA Solar Technology AG shall not be responsible for any damages, including indirect, incidental or consequential damages, caused by reliance on the material presented, including, but not limited to, omissions, typographical errors, arithmetical errors or listing errors in the content material.

SMA Warranty

You can download the current warranty conditions from the Internet at www.SMA-Solar.com.

SOFTWARE LICENSES

The licenses for the installed software modules (open source) can be found in the user interface of the product.

Trademarks

All trademarks are recognized, even if not explicitly identified as such. Missing designations do not mean that a product or brand is not a registered trademark.

SMA Solar Technology AG

Sonnenallee 1

34266 Niestetal

Germany

Tel. +49 561 9522-0

www.SMA.de

E-mail: info@SMA.de

Status: Monday, January 19, 2026

Copyright © 2026 SMA Solar Technology AG. All rights reserved.

Table of contents

1	Information on this Document.....	7
1.1	Validity.....	7
1.2	Target Group.....	7
1.3	Contents and structure.....	7
1.4	Levels of Warning Messages.....	7
1.5	Symbols in the Document.....	7
1.6	Typographies in the document.....	8
1.7	Designations in the Document.....	8
1.8	Additional Information.....	8
2	Safety.....	10
2.1	Intended Use.....	10
2.2	IMPORTANT SAFETY INSTRUCTIONS.....	10
3	Scope of Delivery.....	14
4	Scope of delivery of Charging Station Column.....	16
5	Product overview.....	20
5.1	Device function.....	20
5.2	System Overview.....	21
5.2.1	SMA eCharger in Stand-Alone Mode.....	21
5.2.2	SMA eCharger with Sunny Home Manager.....	21
5.2.3	SMA eCharger with SMA Data Manager M.....	22
5.2.4	Circuitry Overview.....	23
5.2.5	Communication Overview.....	25
5.3	Product Description.....	26
5.4	Symbols on the Product.....	27
5.5	Interfaces and Functions.....	28
5.5.1	User Interface.....	28
5.5.2	Device Key (DEV KEY).....	28
5.5.3	SMA PUK2.0.....	28
5.5.4	Digital inputs.....	28
5.5.5	Modbus.....	28
5.5.6	SEMP protocol.....	29
5.5.7	Grid Management Services.....	29
5.5.8	SMA Smart Connected.....	29
5.5.9	SMA Speedwire.....	29
5.5.10	Wi-Fi.....	29
5.5.11	Wi-Fi connection to SMA 360° app and SMA Energy app.....	29
5.5.12	RS485 interface.....	29
5.5.13	Multifunction relay (MFR).....	30
5.5.14	Charging release.....	30
5.5.15	Knock sensor.....	30
5.5.16	LCD.....	30
5.6	LED Signals.....	30
6	Mounting.....	33
6.1	Requirements for Mounting.....	33
6.1.1	Requirements for the Mounting Location.....	33
6.1.2	Permitted and prohibited mounting positions.....	33
6.1.3	Dimensions for mounting.....	35
6.1.4	Recommended clearances for mounting.....	36

6.2	Wall Mounting.....	38
6.3	Mounting the Charging Station Column	44
7	Electrical Connection.....	53
7.1	Requirements for the electrical connection.....	53
7.1.1	Permitted grid configurations.....	53
7.1.2	Residual-current monitoring unit	54
7.1.3	Load-break switch and cable protection.....	54
7.1.4	Overvoltage category.....	54
7.1.5	AC cable requirements	54
7.1.6	Network cable requirements	55
7.1.7	Signal cable requirements	55
7.1.8	Requirements for the RS485 interface	55
7.2	Overview of the Connection Area.....	56
7.3	Electrical connection procedure	56
7.4	Connecting the Utility Grid.....	57
7.4.1	Multi-EVC operation.....	57
7.4.2	Multi-EVC operation.....	58
7.4.3	Connecting the AC Cable	59
7.5	Connecting the Network Cables	61
7.6	Connecting the Ripple Control Receiver	62
7.6.1	Digital input DI 1-4.....	62
7.6.2	Pin assignment DI 1-4	62
7.6.3	Circuitry overview DI 1-4.....	63
7.6.4	Connecting the ripple control receiver to DI 1-4.....	63
7.7	Connection to digital input DI 5-6	64
7.7.1	Digital input DI 5-6.....	64
7.7.2	Pin assignment DI 5-6	64
7.7.3	Circuitry overview DI 5	64
7.7.4	Circuitry overview DI 6	65
7.7.5	Connecting Signal Source to Digital Input DI 5-6.....	65
7.8	Connection to the Multifunction Relay	66
7.8.1	Digital output (MFR).....	66
7.8.2	Pin assignment MFR	66
7.8.3	Connect signal source to MFR	67
7.8.4	Controlling the loads via multifunction relay	68
7.9	Connecting to the RS485 interface	68
7.9.1	RS485 input.....	68
7.9.2	RS485 pin assignment.....	68
7.9.3	Connecting RS485.....	69
7.10	Close the enclosure cover.....	70
8	Commissioning	71
8.1	Procedure for commissioning in combination with Sunny Home Manager 2.0.....	71
8.2	Procedure for commissioning in secure power supply operation	72
8.3	Procedure for connecting to the SMA Data Manager M.....	72
8.4	Procedure for device configuration	74
8.5	Commissioning the Product	75
8.6	Transfer to the operator.....	78
9	Operation	79
9.1	Design of the User Interface.....	79
9.2	Establishing a Connection to the User Interface of the Product.....	80
9.2.1	Information on establishing a connection	80

9.2.2	Connection in the local network.....	80
9.2.2.1	Access addresses for the product in the local network.....	80
9.2.2.2	Ports for data communication in the local network.....	80
9.2.2.3	Establishing a Connection via Ethernet in the local network.....	81
9.2.2.4	Establishing a Connection via WLAN in the Local Network.....	81
9.2.3	Direct connection via Wi-Fi.....	82
9.2.3.1	Connection options for Wi-Fi direct connection.....	82
9.2.3.2	Access information for direct Wi-Fi connection.....	82
9.2.3.3	Establishing a direct Wi-Fi connection with WPS.....	82
9.2.3.4	Establishing direct Wi-Fi connection with Wi-Fi network search.....	82
9.2.4	WPS function.....	83
9.2.4.1	Connection options with WPS.....	83
9.2.4.2	Activating WPS for automatic connection.....	83
9.2.4.3	Activating WPS for direct connection to a smart device.....	83
9.3	Configuring Service Access.....	83
9.4	User Management.....	84
9.4.1	Access rights to the user interface.....	84
9.4.2	Add new user.....	84
9.4.3	Changing User Rights or User Information.....	84
9.4.4	Delete user accounts.....	84
9.5	Device Administration.....	85
9.5.1	Register Devices.....	85
9.5.2	Delete devices.....	85
9.5.3	Configure device.....	85
9.5.4	Modbus.....	86
9.5.4.1	SMA Modbus Client Profile.....	86
9.5.4.2	Creating a New Modbus Client Profile.....	86
9.5.4.3	Registering a New Modbus Device and Assigning a Modbus Profile.....	86
9.6	Changing parameters.....	87
9.7	I/O configuration.....	87
9.7.1	Digital output (MFR).....	87
9.7.1.1	Use of the digital output (MFR).....	87
9.7.1.2	Configure the digital output (MFR).....	87
9.7.2	Configuring the fast stop function.....	88
9.8	Update and backup.....	88
9.8.1	Automatically Updating the Firmware.....	88
9.8.2	Performing a Manual Firmware Update via the User Interface.....	89
9.8.3	Function and content of the backup file.....	89
9.8.4	Creating a Backup File.....	90
9.9	Resetting the product to default setting.....	90
9.10	Activating the Charging Release.....	91
9.11	Teaching RFID cards.....	91
9.12	Set ambient lighting.....	92
9.13	Starting and Ending the Charging Process.....	92
9.13.1	Properties of Charging Modes.....	92
9.13.2	Authorizing the charging process via RFID card.....	94
9.13.3	Authorizing the charging process via Energy App.....	96
9.13.4	Ending the Charging Process.....	97
10	Disconnecting the product from voltage sources.....	99
11	Maintenance.....	101
12	Cleaning.....	102
13	Troubleshooting.....	103

13.1	Create Diagnostics Data	103
13.2	Event messages.....	103
14	Decommissioning the Product.....	120
15	Replacing the Product.....	121
16	Disposal	122
17	Technical Data	123
17.1	Inputs and outputs (AC)	123
17.2	Communication	123
17.3	Protective Devices	123
17.4	General Data	123
17.5	Equipment.....	124
17.6	Digital inputs	124
17.7	Digital output (multifunction relay).....	125
17.8	Data Storage Capacity	125
17.9	Climatic Conditions.....	125
17.10	Torques.....	125
18	Accessories	126
19	Contact	129
20	EU Declaration of Conformity	130

1 Information on this Document

1.1 Validity

This document is valid for:

- EVC22-3AC-20 (SMA eCharger 22)

1.2 Target Group

This document is intended for qualified persons and end users. Only qualified persons are allowed to perform the activities marked in this document with a warning symbol and the caption "Qualified person". Tasks that do not require any particular qualification are not marked and can also be performed by end users. Qualified persons must have the following skills:

- Knowledge of how the product works and is operated
- Training in how to deal with the dangers and risks associated with installing, repairing and using electrical devices and installations
- Training in the installation and commissioning of electrical devices and installations
- Knowledge of all applicable laws, regulations, standards, and directives
- Knowledge of and compliance with this document and all safety information

1.3 Contents and structure

This document describes the mounting, installation, commissioning, configuration, operation, troubleshooting and decommissioning of the product as well as the operation of the product user interface.

You will find the latest version of this document and further information on the product in PDF format and as eManual at www.SMA-Solar.com. You can also call up the eManual via the user interface of the product.

Illustrations in this document are reduced to the essential information and may deviate from the real product.

1.4 Levels of Warning Messages

The following levels of warning messages may occur when handling the product.

DANGER

Indicates a hazardous situation which, if not avoided, will result in death or serious injury.

WARNING

Indicates a hazardous situation which, if not avoided, could result in death or serious injury.

CAUTION



Indicates a hazardous situation which, if not avoided, could result in minor or moderate injury.

NOTICE

Indicates a situation which, if not avoided, can result in property damage.

1.5 Symbols in the Document

Symbol	Explanation
	Information that is important for a specific topic or goal, but is not safety-relevant

Symbol	Explanation
<input type="checkbox"/>	Indicates a requirement for meeting a specific goal
<input checked="" type="checkbox"/>	Required result
	Example
 QUALIFIED PERSON	Sections describing activities to be performed by qualified persons only

1.6 Typographies in the document

Typography	Use	Example
bold	<ul style="list-style-type: none"> Messages Terminals Elements on a user interface Elements to be selected Elements to be entered 	<ul style="list-style-type: none"> Connect the insulated conductors to the terminals X703:1 to X703:6. Enter 10 in the field Minutes.
>	<ul style="list-style-type: none"> Connects several elements to be selected 	<ul style="list-style-type: none"> Go to Settings > Date.
[Button] [Key]	<ul style="list-style-type: none"> Button or key to be selected or pressed 	<ul style="list-style-type: none"> Select [Enter].
#	<ul style="list-style-type: none"> Placeholder for variable components (e.g., parameter names) 	<ul style="list-style-type: none"> Parameter WClHz.Hz#

1.7 Designations in the Document

Complete designation	Designation in this document
SMA eCharger	Charging station, product

1.8 Additional Information

For more information, please go to www.SMA-Solar.com.

Title and information content	Type of information
"Compatibility between common grid configurations and SMA inverters and SMA charging stations"	Technical Information
"Parameters and Measured Values" Device-specific overview of all parameters and measured values and their setting options Information about the SMA Modbus registers	Technical Information
"SUNNY PORTAL powered by ennexOS"	User Manual
"PUBLIC CYBER SECURITY - Guidelines for a Secure PV System Communication"	Technical Information
"SMA Smart Home"	Planning guidelines
SMA SMART HOME - Compatibility list for the Sunny Home Manager 2.0	Technical Information

Title and information content	Type of information
"SMA Modbus ®-interface - ennexOS" Information on the SMA Modbus interface	Technical Information
"SMA GRID GUARD 10.0 - Grid Management Services via Inverter and System Controller"	Technical Information
Answers to frequently asked questions	FAQs in Sunny Portal and at On-line Service Center

2 Safety

2.1 Intended Use

The SMA eCharger is an AC charging station for standard-compliant charging of an electric vehicle in accordance with IEC 61851-1 MODE 3. The SMA eCharger is designed for use in private and semi-public areas with restricted access (e.g. private property, company parking lot, depot).

The product is intended exclusively for charging electric and plug-in hybrid vehicles, hereinafter referred to as "vehicle":

- Mode 3 charging in accordance with IEC 61851-1 for electric vehicles with non-gassing batteries.
- Socket configurations in accordance with IEC 62196.

The product meets the European standard minimum requirements for charging point labeling in accordance with EN 17186. This does not replace any additional national requirements that may have to be observed.

Only interfaces officially approved by SMA Solar Technology AG (e.g., SEMP, Modbus) may be used for (fully) automated control of the product by third-party applications. In particular, the (fully) automated, frequent setting of parameters is considered improper use.

The product is suitable for indoor and outdoor use.

The product must only be used as stationary equipment.

The product must be tested and commissioned in fast charging mode in accordance with IEC 61851-1 before the first charging process using a suitable measuring device for charging stations.

All components must remain within their permitted operating ranges and their installation requirements at all times.

The product must only be used in countries for which it is approved or released by SMA Solar Technology AG and the grid operator.

The products by SMA Solar Technology AG are not suitable for use in

- Medical devices, in particular products for supplying life-support systems and machines,
- Aircraft, the operation of aircraft, the supply of critical airport infrastructure and airport systems,
- Rail vehicles, the operation and supply of rail vehicles and their critical infrastructure.

The above list is not exhaustive. Contact us if you are unsure whether products by SMA Solar Technology AG are suitable for your application.

Use SMA products only in accordance with the information provided in the enclosed documentation and with the locally applicable laws, regulations, standards and directives. Any other application may cause personal injury or property damage.

The documentation must be strictly followed. Deviations from the described actions and the use of materials, tools, and aids other than those specified by SMA Solar Technology AG are expressly forbidden.

Alterations to the SMA products, e.g., changes or modifications, are only permitted with the express written permission of SMA Solar Technology AG. Unauthorized alterations as well as failure to observe the documentation will void guarantee and warranty claims and in most cases terminate the operating license. SMA Solar Technology AG shall not be held liable for any damage caused by such changes.

Any use of the product other than that described in the Intended Use section does not qualify as appropriate.

The documentation supplied is an integral part of SMA products. Keep the documentation in a convenient, dry place for future reference and observe all instructions contained therein.

This document does not replace any regional, state, provincial, federal or national laws, regulations or standards that apply to the installation, electrical safety and use of the product. SMA Solar Technology AG assumes no responsibility for the compliance or non-compliance with such laws or codes in connection with the installation of the product.

The type label must remain permanently attached to the product.

2.2 IMPORTANT SAFETY INSTRUCTIONS

Keep the manual for future reference.

This section contains safety information that must be observed at all times when working.

The product has been designed and tested in accordance with international safety requirements. As with all electrical or electronical devices, some residual risks remain despite careful construction. To prevent personal injury and property damage and to ensure long-term operation of the product, read this section carefully and observe all safety information at all times.

⚠ DANGER

Danger to life due to electric shock when live components or cables are touched

High voltages are present in the conductive components or cables of the product. Touching live parts and cables results in death or lethal injuries due to electric shock.

- Do not touch non-insulated parts or cables.
- Disconnect the product from voltage sources and ensure it cannot be reconnected before working on the device.
- Wear suitable personal protective equipment for all work on the product.

⚠ DANGER

Danger to life due to electric shock in case of overvoltages and if surge protection is missing

Overvoltages (e.g., in the event of a flash of lightning) can be further conducted into the building and to other connected devices in the same network via the network cables or other data cables if there is no surge protection. Touching live parts and cables results in death or lethal injuries due to electric shock.

- Ensure that all devices in the same network are integrated in the existing overvoltage protection.
- When laying the network cable outdoors, ensure that there is suitable surge protection at the network cable transition from the product outdoors to the network inside the building.
- The Ethernet interface of the product is classified as "TNV-1" and offers protection against overvoltages of up to 1.5 kV.

⚠ WARNING

Risk of injury due to toxic substances, gases and dusts

In rare cases, damages to electronic components can result in the formation of toxic substances, gases or dusts inside the product. Touching toxic substances and inhaling toxic gases and dusts can cause skin irritation, burns or poisoning, trouble breathing and nausea.

- Only perform work on the product (e.g., troubleshooting, repair work) when wearing personal protective equipment for handling of hazardous substances (e.g., safety gloves, eye and face protection, respiratory protection).
- Ensure that unauthorized persons have no access to the product.

⚠ WARNING

Danger due to wet or contaminated connectors

Serious injuries or property damage can result due to burns caused by permanent exposure.

- Only mount the product vertically.
- Dry wet connectors in a de-energized state.
- Visually inspect the plug before use.
- Clean dirty connectors in a de-energized state.

⚠ WARNING**Danger when driving or rolling away with charging cable still attached**

This can result in serious injuries or property damage.

- Disconnect the charging cable from the vehicle before leaving.
- Do not bypass the vehicle's safety device.

⚠ CAUTION**Risk of injury due to weight of product**

Injuries may result if the product is lifted incorrectly or dropped while being transported or mounted.

- Transport and lift the product carefully. Take the weight of the product into account.
- Wear suitable personal protective equipment for all work on the product.

NOTICE**Damage to the product due to sand, dust and moisture ingress**

Sand, dust and moisture penetration can damage the product and impair its functionality.

- Only open the product if the humidity is within the thresholds and the environment is free of sand and dust.
- Do not open the product during a dust storm or precipitation.

NOTICE**High costs due to inappropriate Internet tariff**

Depending on use, the data volume of the product transferred via the Internet may vary in size. The data volume depends, for example, on the number of devices in the system, the frequency of device updates, the frequency of data transfer to Sunny Portal or the use of FTP push. High costs for the Internet connection can be the result.

- SMA Solar Technology AG recommends using an Internet flat rate.

NOTICE**Damage to the vehicle during emergency or battery-backup operation**

During emergency or battery-backup operation, three-phase loads may be connected to a single-phase utility grid with phase coupling. This can damage the vehicle.

- Emergency and battery-backup operation must be clarified with and approved by the vehicle manufacturer in advance.
- Ensure that, during phase coupling, only single-phase loads are connected to the battery-backup grid.

i High ambient temperature

Safety mechanisms are implemented in the charging station to protect the product against damage due to too high ambient temperatures. For this process, the charging rate of the charging station is gradually reduced (derating). The charging rate depends on the operating temperature.

- Wait until the operating temperature drops.

i **Communication disturbances in the local network**

The IP address range 192.168.12.0 to 192.168.12.255 is occupied for communication amongst SMA products and for direct access to SMA products.

Communication problems might occur if this IP address range is used in the local network.

- Do not use the IP address range 192.168.12.0 to 192.168.12.255 in the local network.

i **DHCP Server is recommended**

The DHCP server automatically assigns the appropriate network settings to your nodes in the local network. A manual network configuration is therefore not necessary. In a local network, the Internet router is usually the DHCP server. If the IP addresses in the local network are to be assigned dynamically, DHCP must be activated in the Internet router (see the Internet router manual). In order to receive the same IP address by the internet router after a restart, set the MAC address binding.

In networks where no DHCP server is active, proper IP addresses must be assigned from the free address pool of the network segment to all network participants to be integrated during commissioning.

3 Scope of Delivery

Check the scope of delivery for completeness and any externally visible damage. Contact your distributor if the scope of delivery is incomplete or damaged.

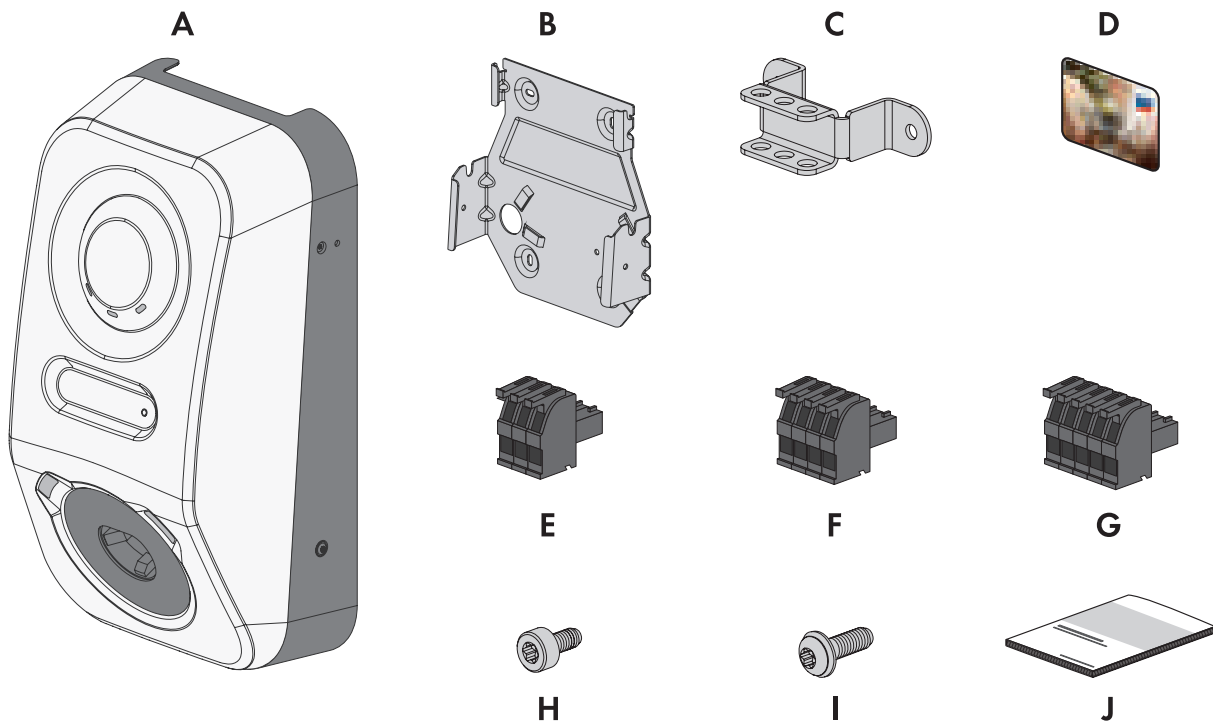

Figure 1: Components included in scope of delivery

Position	Quantity	Designation
A	1	Charging station
B	1	Wall mounting bracket
C	1	Strain relief
D	2	RFID charging card (serial number and UID (Unique Identification) for registering the RFID card to authenticate charging processes)
E	1	3-pole terminal block
F	1	4-pole terminal block
G	2	5-pole terminal block
H	3	Socket head cap screw, M5 x 8

Position	Quantity	Designation
I	2	Pan head screw with flange, M5 x 12
J	1	<p>Documentation package consists of:</p> <ul style="list-style-type: none"> • Safety information booklet • Quick reference guide poster with illustrated instructions for initial installation and commissioning • Sheet with a password label contains the following information: <ul style="list-style-type: none"> - PIC (Product Identification Code) identification key for registering the system in Sunny Portal - RID (Registration Identifier) registration ID for registering the system in Sunny Portal - Wi-Fi password WPA2-PSK (WiFi Protected Access 2 - Preshared Key) for direct connection to the product via Wi-Fi - Device Key (DEV KEY) for resetting the administrator password

See also the following video for additional information:

TechTip: Unboxing SMA eCharger I DE



TechTip: Unboxing SMA eCharger I EN



4 Scope of delivery of Charging Station Column

Check the scope of delivery for completeness and any externally visible damage. Contact your distributor if the scope of delivery is incomplete or damaged.

Charging station column of SMA eCharger (single-sided)

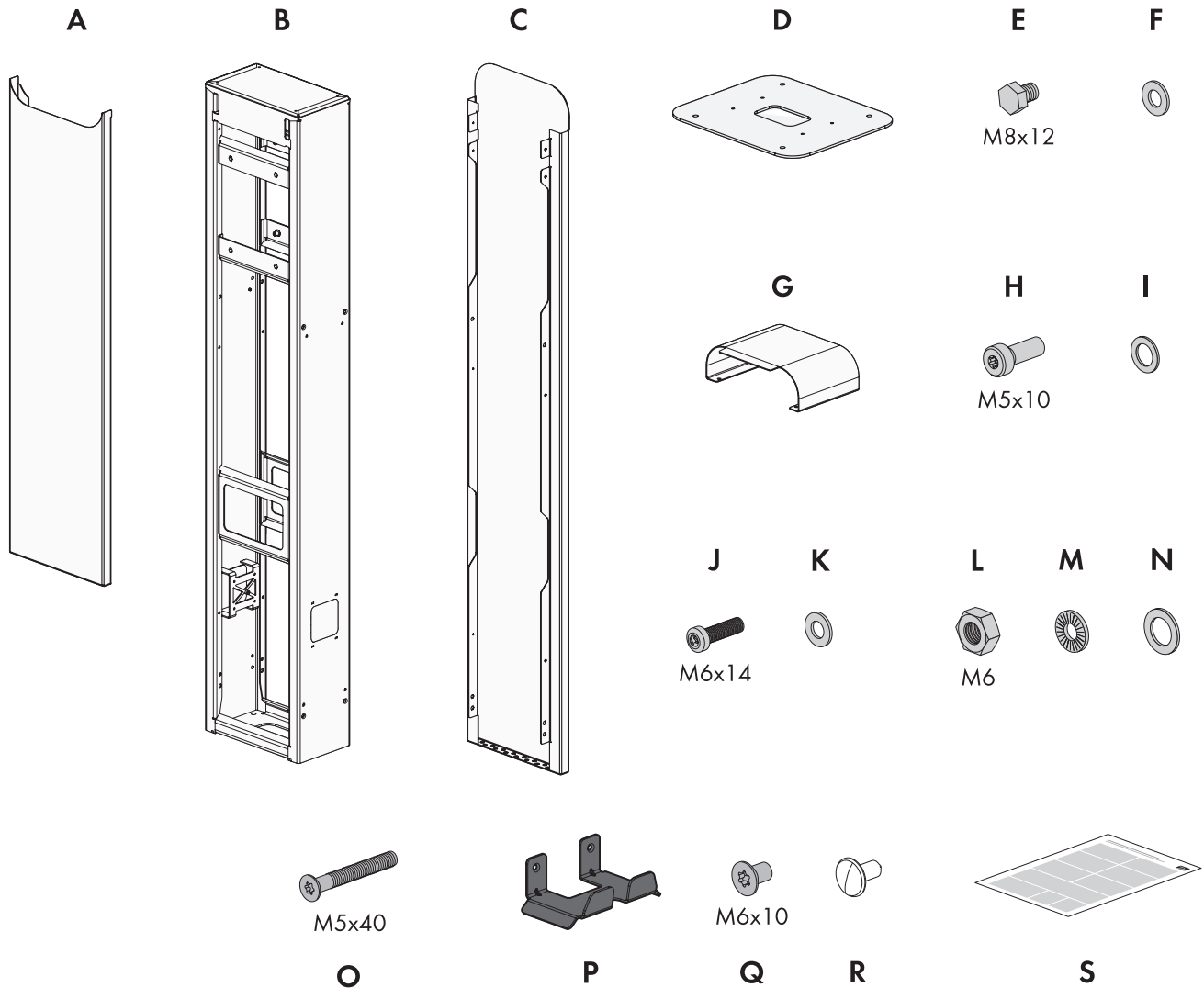

Figure 2: Components included in scope of delivery

Position	Quantity	Designation
A	1	Cover, front
B	1	Middle section
C	1	Cover, rear
D	1	Base plate
E	4	Screw M8x12
F	4	Washer M8
G	1	Lid

Position	Quantity	Designation
H	4	Screw M5x10
I	4	Washer M5
J	4	Screw M6x14
K	4	Washer M6
L	1	Nut M6
M	1	Serrated lock washer M6
N	1	Washer M6
O	8	Screw M5x40
P	1	Cable bracket
Q	2	Screw M6x10
R	2	Fir tree clip
S	1	Manual

Charging station column of SMA eCharger (double-sided)

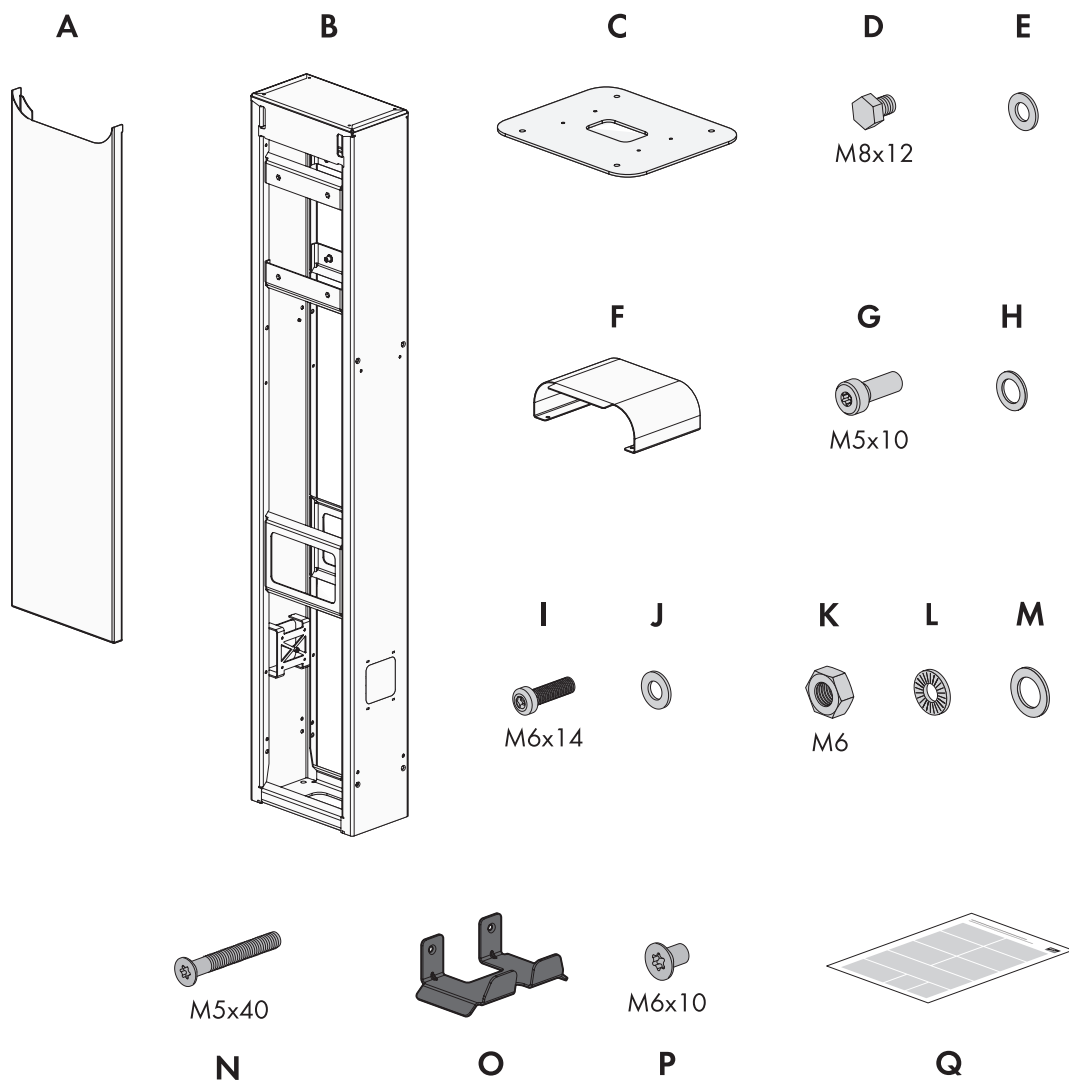

Figure 3: Components included in scope of delivery

Position	Quantity	Designation
A	2	Cover (front and rear)
B	1	Middle section
C	1	Base plate
D	4	Screw M8x12
E	4	Washer M8
F	1	Lid
G	4	Screw M5x10
H	4	Washer M5
I	8	Screw M6x14
J	8	Washer M6

Position	Quantity	Designation
K	1	Nut M6
L	1	Serrated lock washer M6
M	1	Washer M6
N	8	Screw M5x40
O	2	Cable bracket
P	4	Screw M6x10
Q	1	Manual

5 Product overview

5.1 Device function

You can use and configure the SMA eCharger as a stand-alone device, in combination with a Sunny Home Manager 2.0, or in combination with the SMA Data Manager M.

You carry out the device configuration via the commissioning wizard.

i **The SMA eCharger must always be configured in the role of System Manager in the commissioning wizard (regardless of which system configuration is selected).**

Charging station in stand-alone mode

If the charging station is configured for stand-alone mode, the range of functions is limited. Charging with surplus PV energy or a specified target is not possible. If an energy meter is available and configured, then power outage protection and unbalanced load control are active. The SMA eCharger then adjusts to the values measured by the Energy Meter.

Charging station with Sunny Home Manager 2.0

When the charging station is configured in combination with Sunny Home Manager 2.0, the Sunny Home Manager 2.0 takes over control of the system.

Information: Although the Sunny Home Manager 2.0 is set up as the System Manager, the SMA eCharger must also be set up as a System Manager because it includes a meter as a subordinate device. In this case, only the Sunny Home Manager 2.0 or SMA Energy Meter must be added via the SMA Speedwire device registration. No SMA inverters may be added. SMA inverters are added to the system via the Sunny Home Manager 2.0 and the Sunny Portal.

Charging station with SMA Data Manager M

The SMA eCharger can be added as a Modbus device for monitoring (not controlling) a system with SMA Data Manager M.

Information: This feature is available as of SMA eCharger **firmware version 2.5.9.R** and SMA Data Manager M (EDMM-10, EDMM-20) **firmware version 2.5.9.R**.

The SMA Data Manager M supports up to 20 SMA eChargers (20 charging points) via Modbus TCP (monitoring only).

5.2 System Overview

5.2.1 SMA eCharger in Stand-Alone Mode

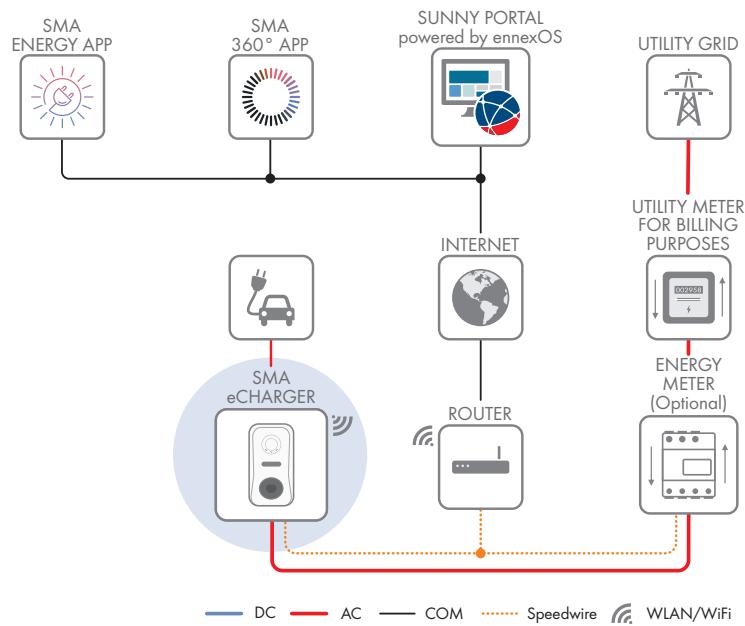

5.2.2 SMA eCharger with Sunny Home Manager

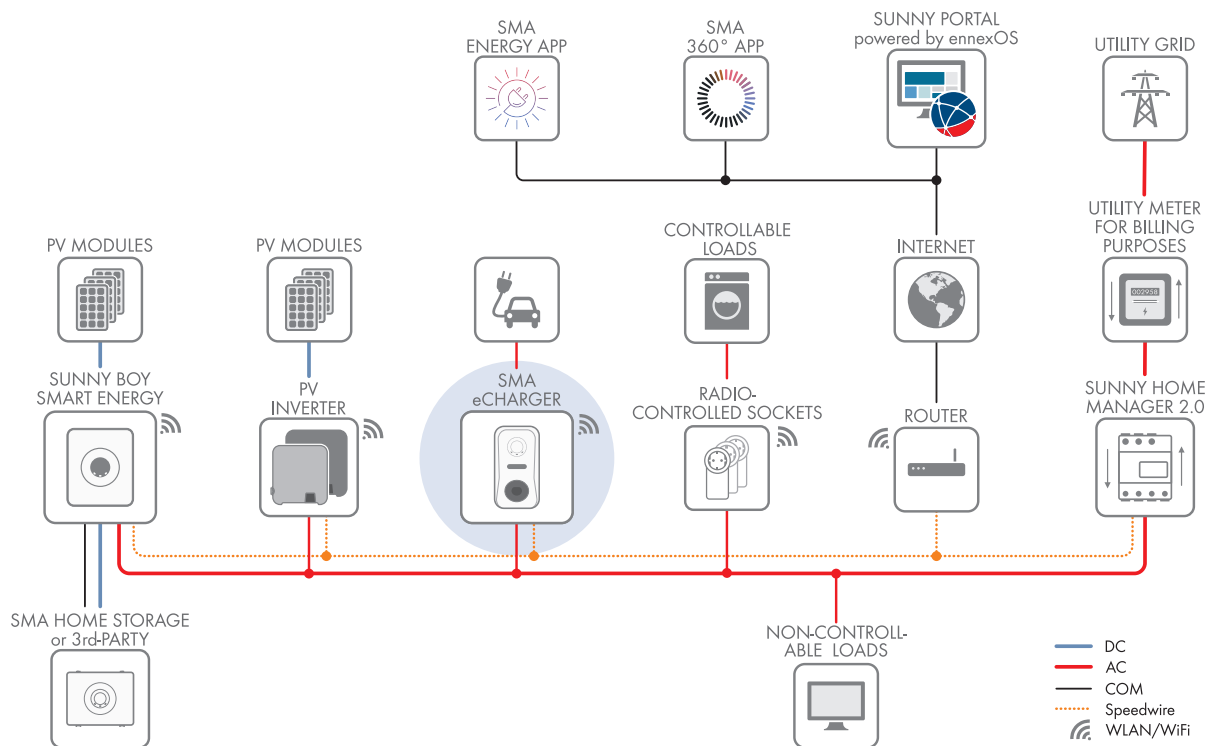

Figure 4: System with SMA eCharger and Sunny Home Manager 2.0

5.2.3 SMA eCharger with SMA Data Manager M

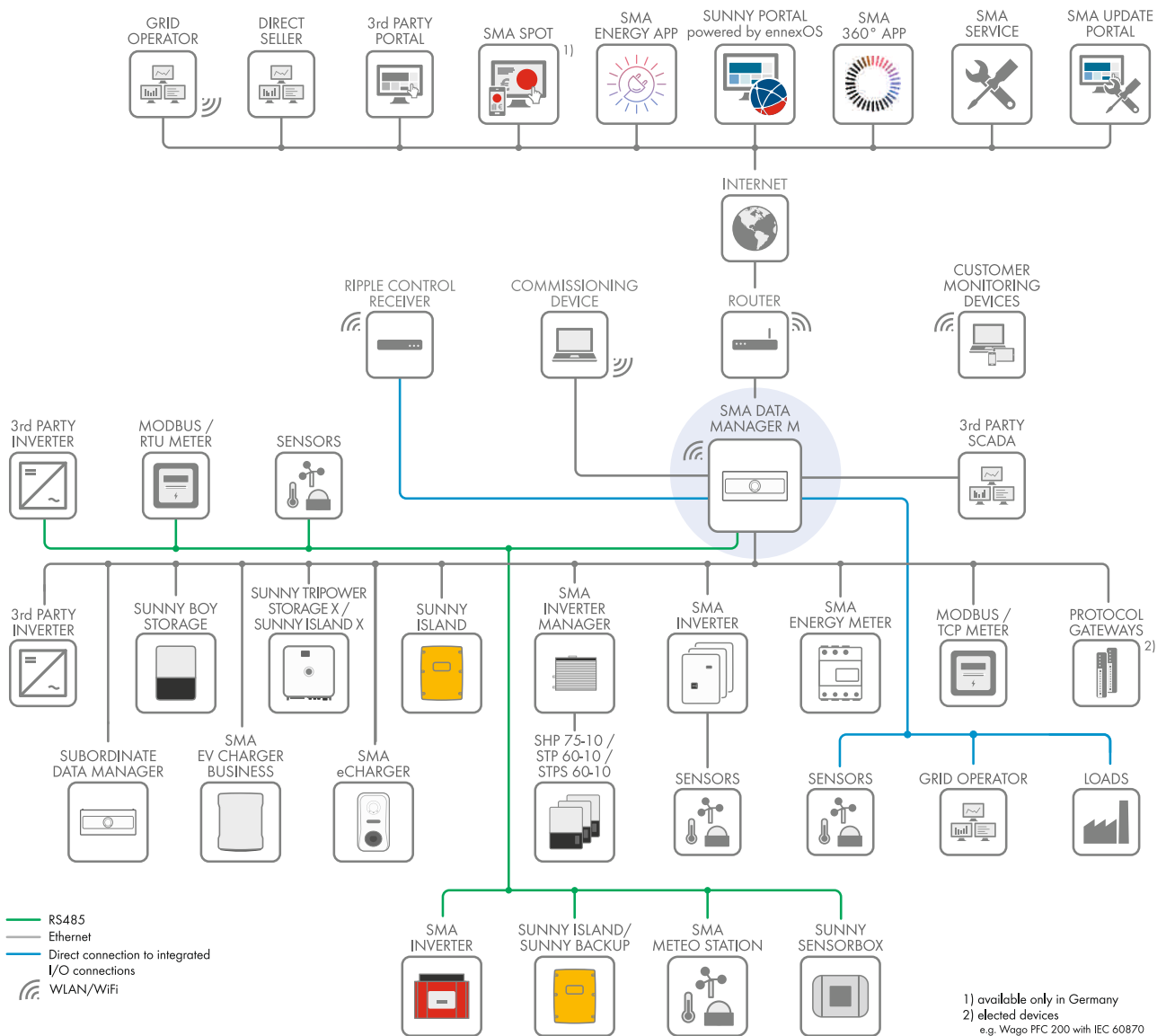

Figure 5: System with SMA eCharger and SMA Data Manager M

5.2.4 Circuitry Overview

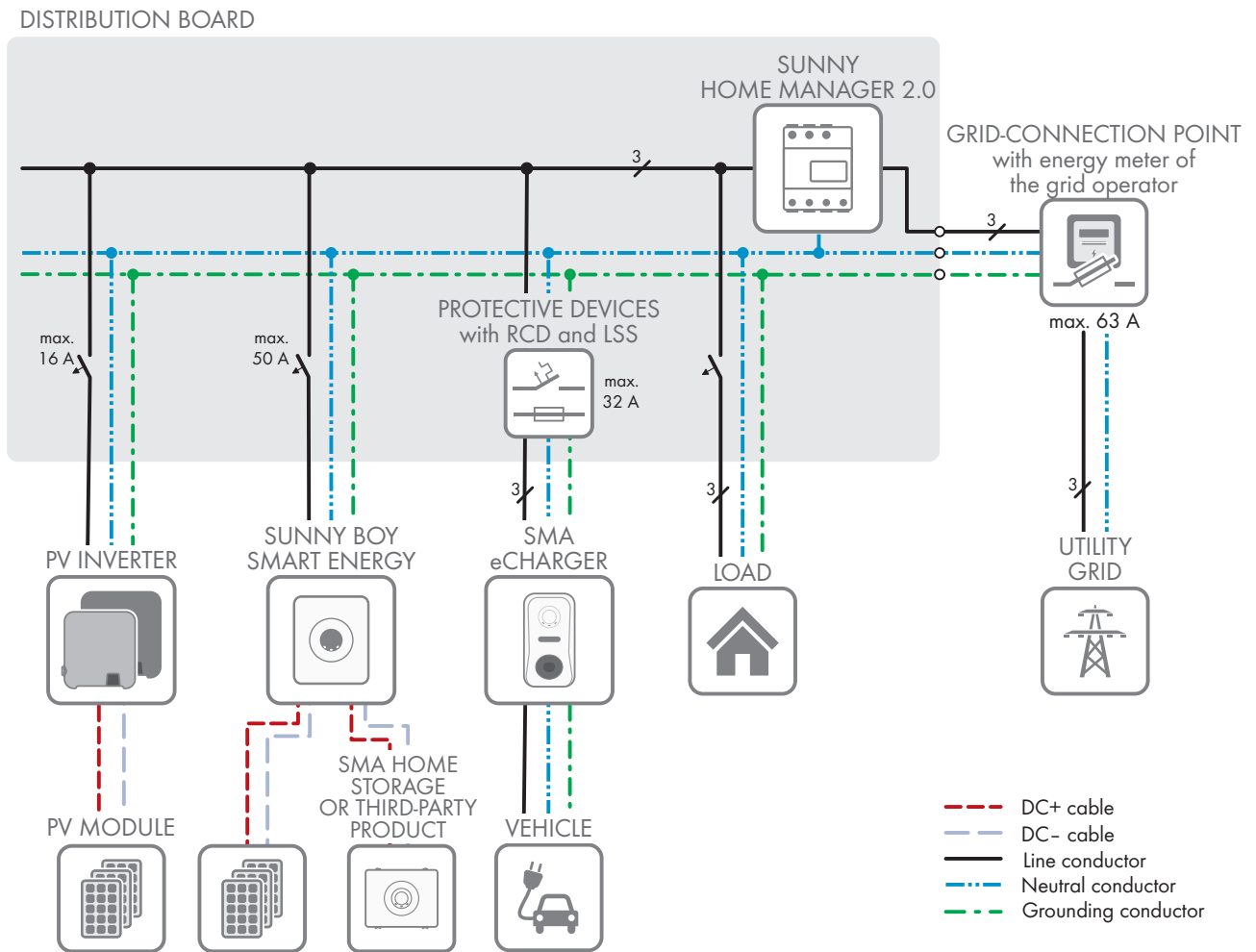

Figure 6: Circuitry overview (example with 1 EVC22-3AC-20)

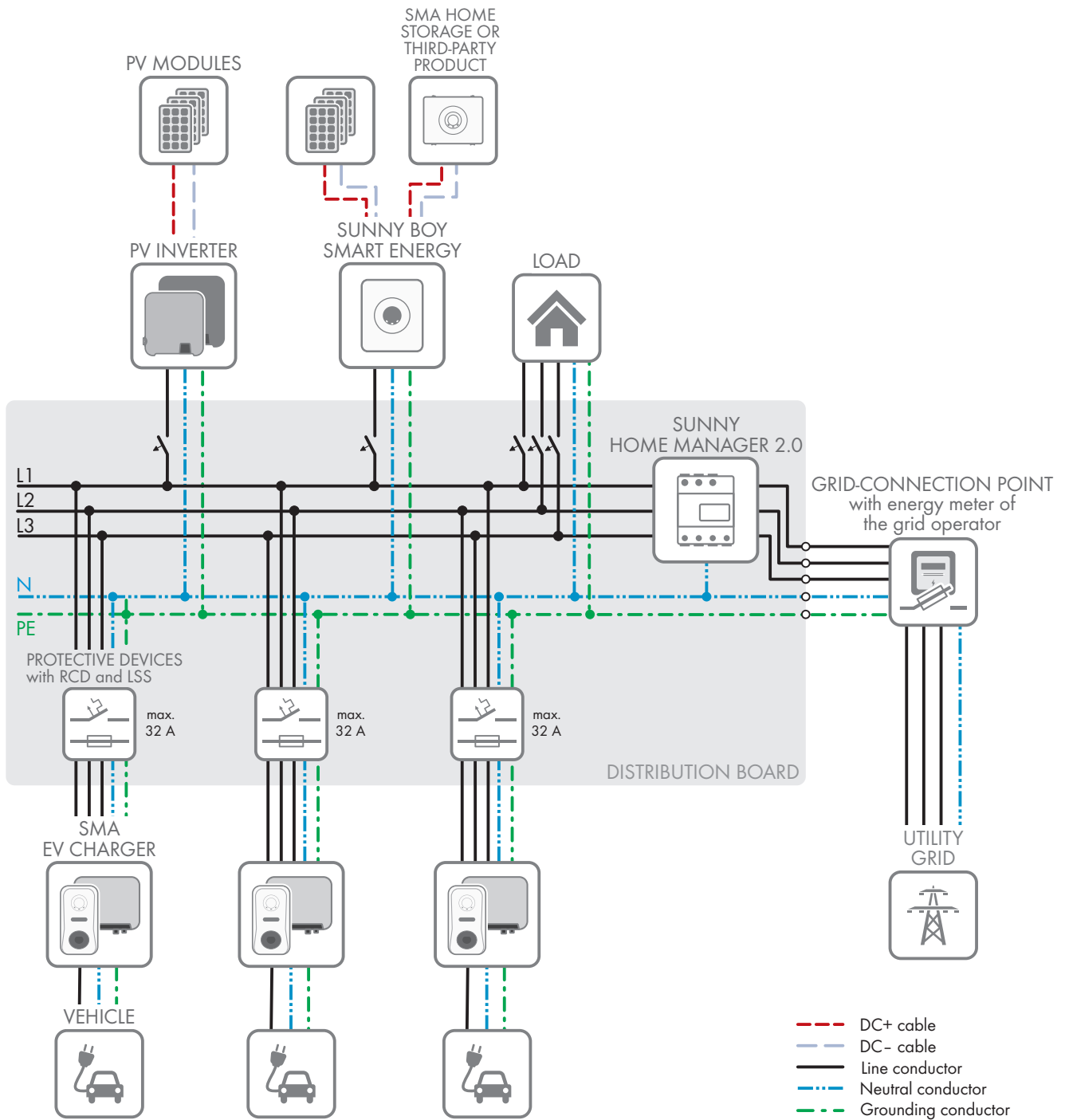

Figure 7: Circuitry overview (example with 3 EVC22-3AC-20)

5.3 Product Description

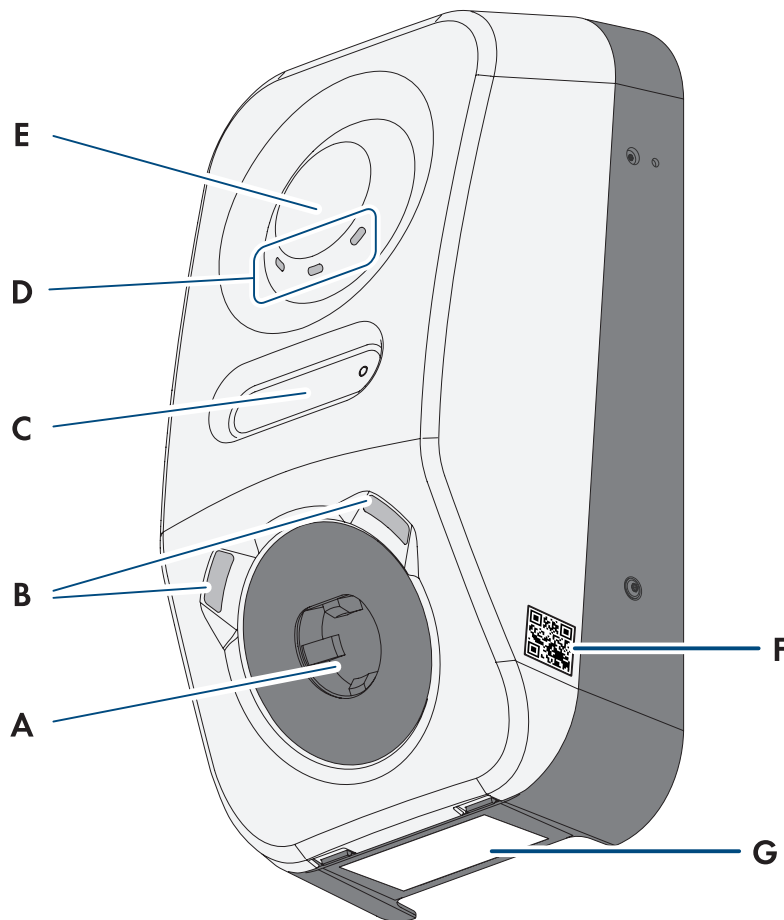













Figure 9: Design of the product

Position	Designation
A	Charging socket for a type 2 charging cable for connecting to an electric vehicle
B	LED ambient lighting. The ambient lighting helps to illuminate the charging location.
C	LCD display and impulse LED Information: The display shows instantaneous values and status information. The flashing impulses of the impulse LED are for testing purposes and implemented for upcoming features.
D	LED status indicator The LEDs indicate the operating state of the product.
E	Interaction area with RFID card reader and knock sensor

Position	Designation
F	A label with a QR code to be scanned using the SMA apps
G	<p>Type label</p> <p>The type label clearly identifies the product. The type label must remain permanently attached to the product. You will find the following information on the type label:</p> <ul style="list-style-type: none"> • Device type (Model) • Serial number (Serial No. or S/N) • Date of manufacture • Device specific characteristics

5.4 Symbols on the Product

Symbol	Explanation
	<p>Beware of electrical voltage</p> <p>The product operates at high voltages.</p>
	<p>Beware of hot surface</p> <p>The product can get hot during operation.</p>
	<p>Observe the documentation</p> <p>Observe all documentations supplied with the product.</p>
	<p>Charge point designation</p> <p>Drivers of electric vehicles can ensure whether their electric is usable with the charging unit and the connector.</p>
	<p>Data transmission</p> <p>Together with the blue LED, this symbol indicates the status of the network connection.</p>
	<p>Alternating current</p>
	<p>WEEE designation</p> <p>Do not dispose of the product together with the household waste but in accordance with the disposal regulations for electronic waste applicable at the installation site.</p>
	<p>The product is suitable for outdoor installation.</p>
IP54	<p>Degree of protection IP54</p> <p>The product is protected against interior dust deposits and against water splashing from all angles against the enclosure.</p>
	<p>CE marking</p> <p>The product complies with the requirements of the applicable EU directives.</p>

Symbol	Explanation
	RoHS labeling The product complies with the requirements of the applicable EU directives.
	RCM (Regulatory Compliance Mark) The product complies with the requirements of the applicable Australian standards.

5.5 Interfaces and Functions

5.5.1 User Interface

The product is equipped as standard with an integrated webserver, which provides a user interface for configuring and monitoring the product.

Once the connection has been established to the smart device, use a device (e.g. smartphone, tablet or laptop) to connect to the product's user interface using a web browser.

Also see:

- [Access rights to the user interface](#) ⇒ page 84

5.5.2 Device Key (DEV KEY)

If you have forgotten the administrator password for the product, you can reset the administrator account with the device key and assign a new password. The device key can be used to prove the identity of the product in digital communication. The Device Key is provided on a sheet with a password label supplied with the product. Keep the device key safe in case you forget the administrator password.

5.5.3 SMA PUK2.0

The PUK (Personal Unlocking Key) is a security code. It is used to reset lost or forgotten passwords for digital devices. The PUK security feature protects against unauthorized access. If passwords and/or product keys are no longer available, there are two procedures depending on the firmware version:

- For PUK for products with firmware version < 2.5.x.R via the Online Service Center
- For PUK2.0 on products with firmware version ≥ 2.5.x.R via the product user interface

5.5.4 Digital inputs

The product is equipped with digital inputs as standard.

Digital input **DI 1-4** is provided for connecting a ripple control receiver or remote terminal unit for regulation by the grid operator (e.g. to fulfill EnWG §14a requirements).

Digital input **DI 5** is intended for connection of a fast-stop switch (break contact).

Digital input **DI 6** is intended for connection of an external grid and PV system protection device (break contact).

5.5.5 Modbus

The product is equipped with a Modbus interface. The Modbus interface is deactivated by default and must be configured as needed.

The Modbus interface of the supported SMA products is designed for industrial use – via SCADA systems, for example – and has the following tasks:

- Remote query of measured values
- Remote setting of operating parameters
- Setpoint specifications for system control

5.5.6 SEMP protocol

The SEMP data protocol (SEMP = Smart Energy Management Protocol) developed by SMA Solar Technology AG allows selected consuming devices to be controlled directly from the Sunny Home Manager 2.0 and integrated into energy management system.

The SEMP interface is **disabled by default** and must be **enabled** for intelligent load control with the Sunny Home Manager.

5.5.7 Grid Management Services

The product is equipped with service functions for grid management.

Depending on the requirements of the grid operator, you can activate and configure the functions (e.g. active power limitation) via operating parameters.

5.5.8 SMA Smart Connected

SMA Smart Connected is the free monitoring of the product via the SMA Sunny Portal. Thanks to SMA Smart Connected, the operator and qualified person will be informed automatically and proactively about product events that occur.

SMA Smart Connected is activated during registration in Sunny Portal. In order to use SMA Smart Connected, it is necessary that the product is permanently connected to Sunny Portal and the data of the operator and qualified person is stored in Sunny Portal and up-to-date.

5.5.9 SMA Speedwire

The product is equipped with SMA Speedwire as standard. SMA Speedwire is a type of communication based on the Ethernet standard. SMA Speedwire is designed for a data transfer rate of 100 Mbps and enables optimum communication between Speedwire devices within systems.

The products supports the encrypted system communication with SMA Speedwire Encrypted Communication. In order to be able to use the Speedwire encryption in the system, all Speedwire devices, except for the energy meter, must support the function SMA Speedwire Encrypted Communication.

5.5.10 Wi-Fi

The product is equipped with a Wi-Fi interface as standard. The inverter is delivered with the WLAN interface activated as standard. If you do not want to use WLAN, you can deactivate the WLAN interface.

In addition, the product has a WPS function. The WPS function is for automatically connecting the product to a network (e.g. via router) and establish a direct connection between the product and a smart device.

5.5.11 Wi-Fi connection to SMA 360° app and SMA Energy app

There is a QR code on the product by default. By scanning the QR Code attached to the product via the SMA 360° app or SMA Energy app, access to the product is established via Wi-Fi and the connection to the user interface is made automatically.

Also see:

- [Direct connection via Wi-Fi ⇒ page 82](#)

5.5.12 RS485 interface

The product is equipped with an RS485 interface as standard. The product can communicate with SMA communication products via the wired RS485 interface (information on supported SMA products at www.SMA-Solar.com).

5.5.13 Multifunction relay (MFR)

The product is equipped with a multifunction relay (digital output) as standard. The multifunction relay is an interface that can be used to control products via an external contactor or to activate external indicator lights to indicate messages.

5.5.14 Charging release

To protect the charging station against unauthorized access, you can activate **charging release**. Once activated, the charging station is locked and each charging process must be released via the SMA Energy App or via an RFID card that has been previously added under access management. Charging approval applies to the active charging process. When charging is complete, the charging station is locked again.

Activation can be performed during commissioning via the installation wizard under **Access management** or during operation via the user interface under **Select charging station > Configuration > Access management**.

5.5.15 Knock sensor

The knock sensor can be used to operate the charging station (see Section 5.3, page 26). The following functions are available:

Knock code	Function
Knock once	Activates the backlight on the display and the ambient lighting
Knock once with lighting activated	Change to display menu
Double knock with charging cable plugged in	Activates rapid charging function and WPS function
Double knock without charging cable plugged in	Activates WPS function

5.5.16 LCD

The LCD shows the current operating data and events or errors. The display can be used to operate the charging station (see Section 5.3, page 26).

Information: Currently, the display language is set to English and cannot be changed.

Tap code	Function
Tap once	Activates the backlight on the display and the ambient lighting
Tap once with lighting activated	Depending on the operating state (booting, charging enabled, or active charging process) of the charging station, various parameters are shown in the display menu.

5.6 LED Signals

i In a current production batch of the SMA eCharger, the center information LED and the impulse LED next to the display were incorrectly fitted with orange LEDs instead of red LEDs as intended.

This color deviation has no effect on functionality, safety or certification of the device.

LED signal	Explanation
Green LED and red LED are flashing simultaneously (2 s on and 2 s off)	Device not configured. Operation of the product is stopped because the initial configuration was not completed. The product automatically starts operation as soon as the configuration has been carried out (e.g. using the commissioning wizard or via a System Manager).
The green LED is glowing	Charging mode Active charging process, the vehicle is being charged.
Green LED is flashing slowly (2 s on and 2 s off)	Waiting for start conditions. The charging station is waiting for specifications from the energy manager (e.g., Sunny Home Manager 2.0).
The green LED flashes quickly (0.25 s on and 0.25 s off)	Fast charging activated Fast charging is started locally at the product by means of the knock code.
Yellow LED on	Charging station is locked; charging release is required in order to start the charging process (e.g. via app or RFID) (see Section 5.5.14, page 30)
Yellow LED is flashing slowly (2 s on and 2 s off)	Automatic registration of new RFID cards is active.
Yellow LED is flashing asymmetrically (1.5 s on and 0.5 s off)	Registration of a new RFID card was completed successfully.
Yellow LED is flashing (0.25 s on, 0.25 s off, 0.25 s on, 1.25 s off)	Authentication failed. RFID card not known / invalid. Charging not released.
Yellow LED is flashing quickly (0.25 s on and 0.25 s off)	Authorization complete. Charging is released.
The red LED is glowing	Error Operation of the product has been stopped. In addition, a distinct event message and the corresponding event number will be displayed on the product user interface or in the Sunny Portal (see Section 13.2, page 103).
Red LED is flashing (0.25 s on, 0.25 s off, 0.25 s on, 1.25 s off)	Warning Communication with the energy manager has failed, or the charging rate is reduced due to a higher-level safety function (e.g. power outage protection). The charging station continues to operate with restricted function. In addition, a distinct event message and the corresponding event number will be displayed on the user interface (see Section 13.2, page 103).
Red LED is flashing (2 s on and 2 s off)	Charging process interrupted. Incompatible vehicle.
Blue LED is flashing slowly (2 s on and 2 s off)	Communication connection is being established. The product is establishing a connection with a local network or is establishing a direct connection to a smart device (e.g., smartphone, tablet or laptop).

LED signal	Explanation
Blue LED is flashing quickly (0.25 s on and 0.25 s off)	The function "Find device" (Parameter.Sys.DevSig) has been activated via the System Manager. The product identifies itself accordingly.
The blue LED is glowing	There is an active connection with a local network or there is a direct connection with a smart device (e.g., smartphone, tablet or laptop).
Blue LED is off	There is no active communication connection.
All 3 LEDs are on	Product update or booting procedure.
Ambient lighting at the type 2 charging port	The ambient lighting helps to illuminate the charging location in the dark.

Information: The ambient lighting and brightness level of the LED can be configured (see Section 9.12, page 92).

6 Mounting

6.1 Requirements for Mounting

6.1.1 Requirements for the Mounting Location

i Grid operator registration requirement

Find out from the grid operator whether there is a registration requirement, and register the charging station with the grid operator if required.

⚠ WARNING

Danger to life due to fire or explosion

Despite careful construction, electrical devices can cause fires. This can result in death or serious injury.

- Do not mount the product in areas containing highly flammable materials or gases.
- Do not mount the product in potentially explosive atmospheres.

- A solid, flat support surface must be available for mounting.
- The support surface for installation must be made of a non-flammable material.
- Installation must be carried out so that the charging port is always at a height of 1.2 m to 1.5 m above floor level (see Section 6.1.4, page 36).
- The installation site must be selected so that the product and the vehicle can be connected with the charging cable. The charging cable must not be strained, squeezed or bent.
- No other device may be installed under the product.
- The product should be mounted in such a way that display messages and LED signals can be read without difficulty (see Section 6.1.4, page 36).
- The mounting location must be suitable for the weight and dimensions of the product.
- The installation site must be less than 2000 m above mean sea level.
- The installation site can be exposed to direct solar irradiation. There is, however, the possibility that the product reduces its power output to avoid overheating due to high temperatures.
- The installation site should be freely and safely accessible at all times without the need for any auxiliary equipment (such as scaffolding or lifting platforms). Non-fulfillment of these criteria may restrict servicing.
- All ambient conditions must be met (see Section 17.9, page 125).
- The ambient temperature should be considered (see Section 17.4, page 123) to ensure optimal operation.

6.1.2 Permitted and prohibited mounting positions

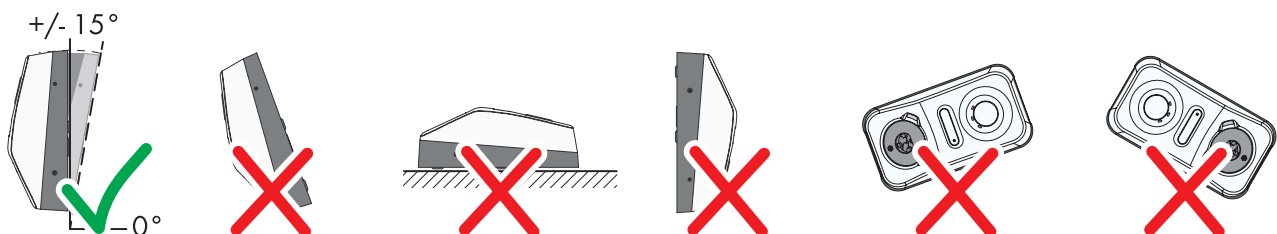

Figure 10: Permitted and prohibited mounting positions

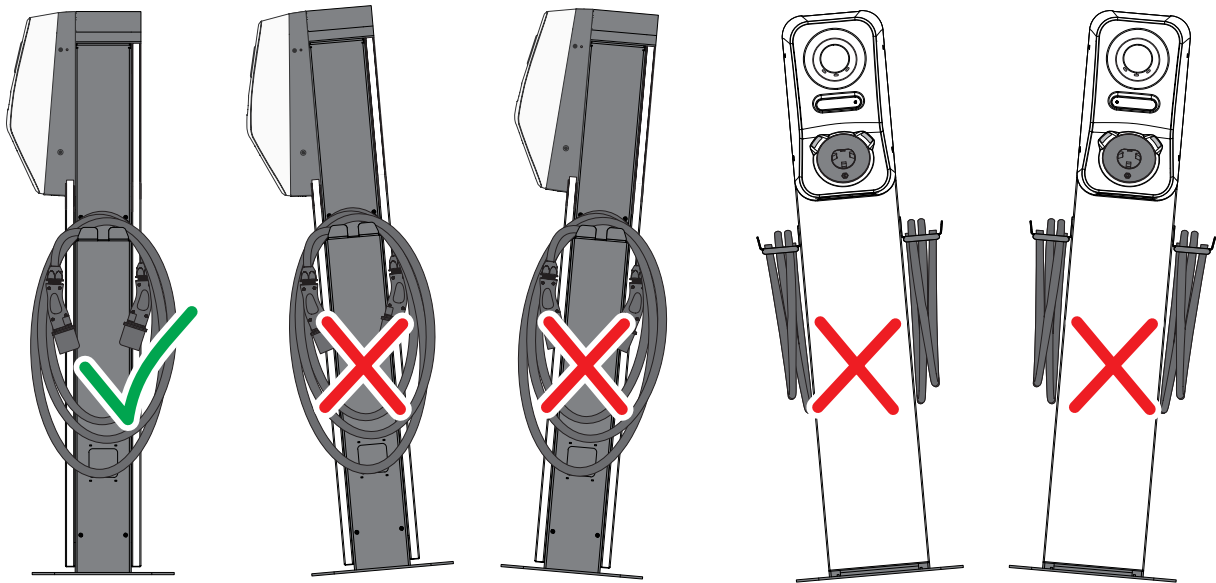

Figure 11: Permitted and prohibited mounting positions

6.1.3 Dimensions for mounting

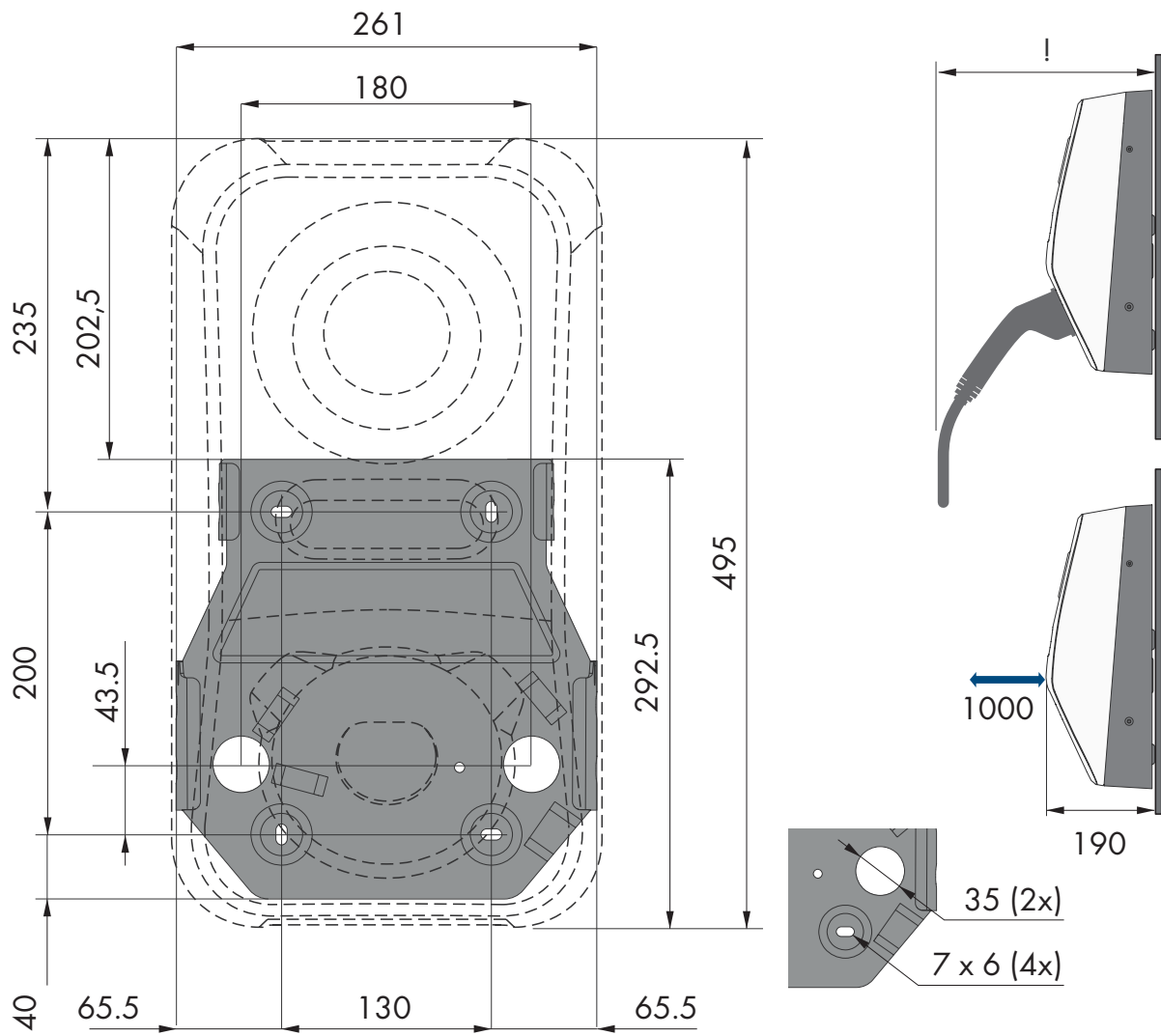

Figure 12: Position of the anchoring points (Dimensions in mm)

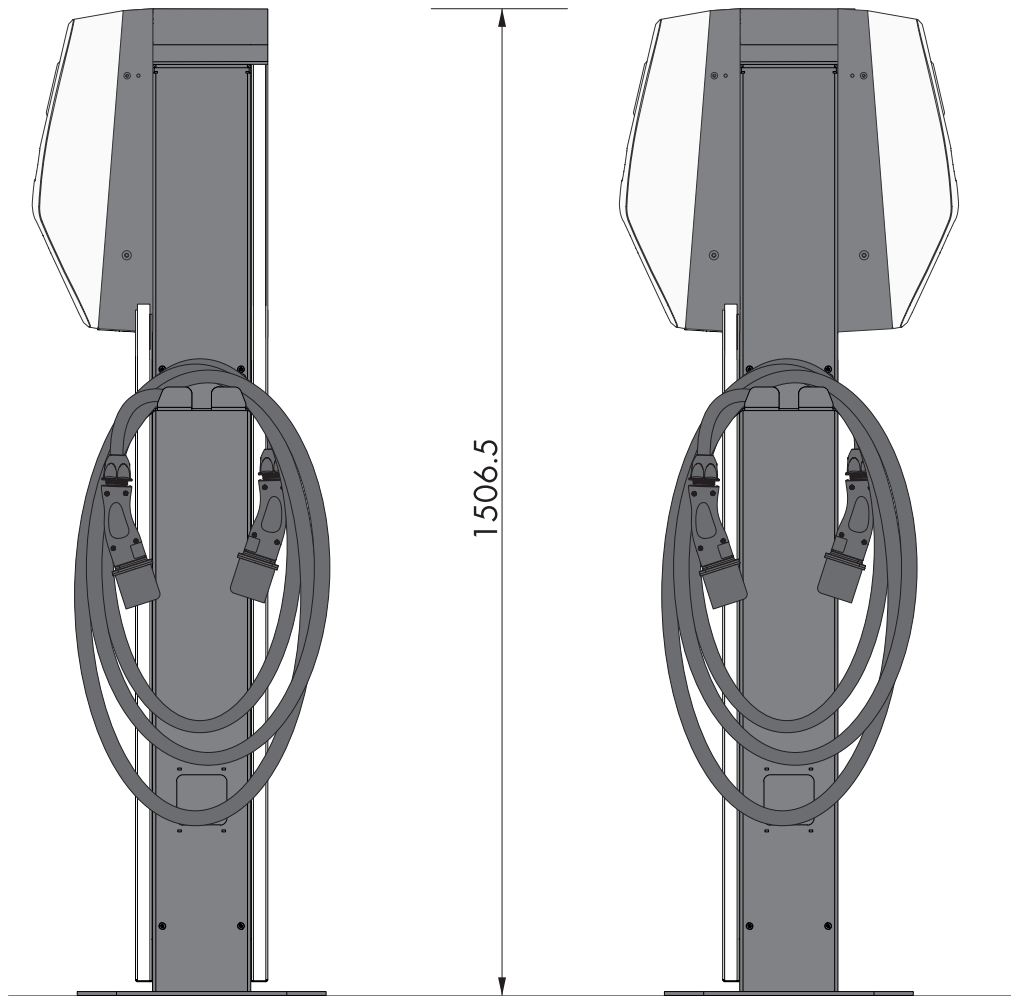

Figure 13: Position of the anchoring points (Dimensions in mm)

6.1.4 Recommended clearances for mounting

Requirements:

- Recommended distances to walls, other devices and objects should be maintained.
- If multiple products are mounted in areas with high ambient temperatures, increase the clearances between the products and ensure sufficient fresh-air supply.

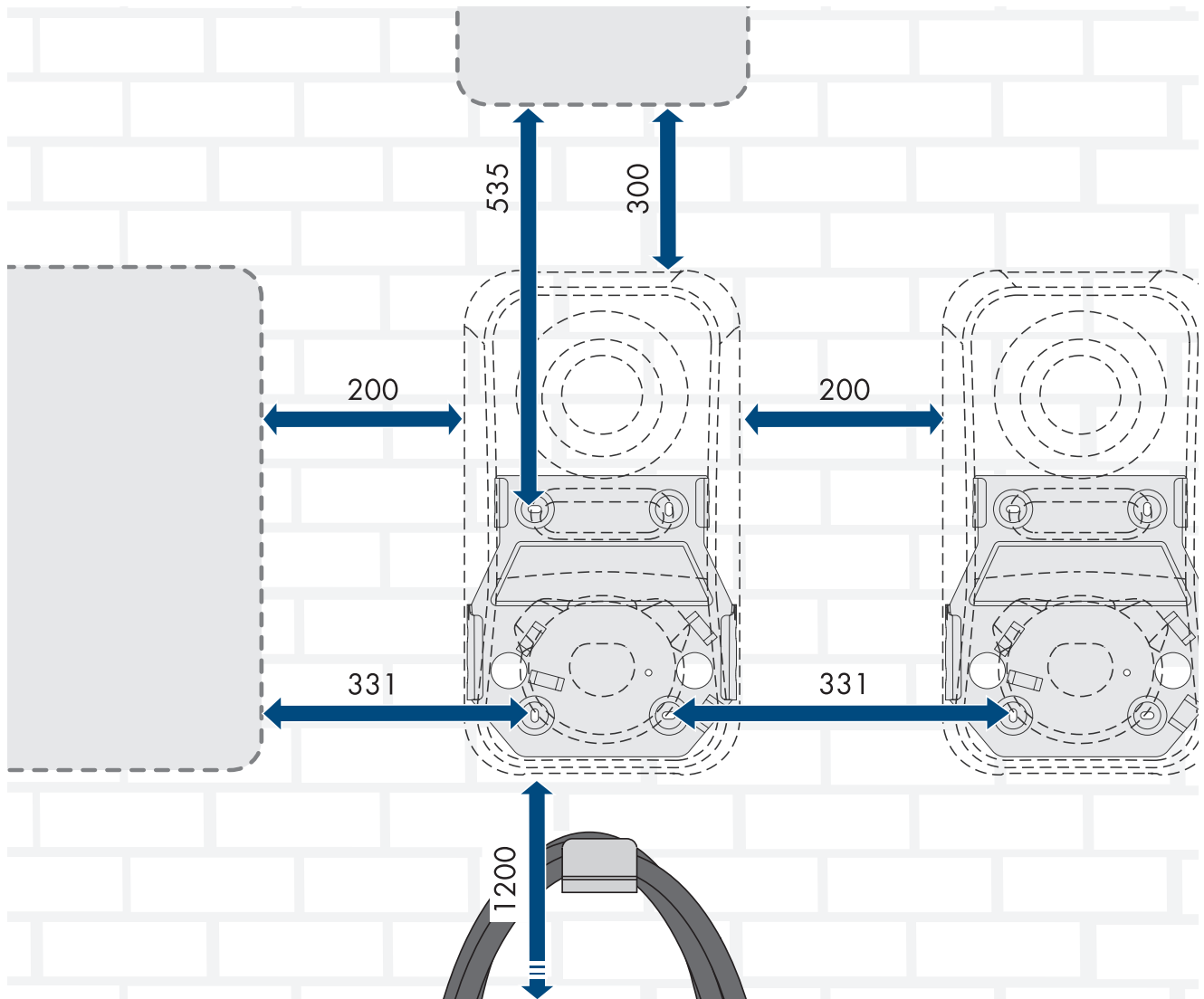

Figure 14: Recommended clearances (Dimensions in mm)

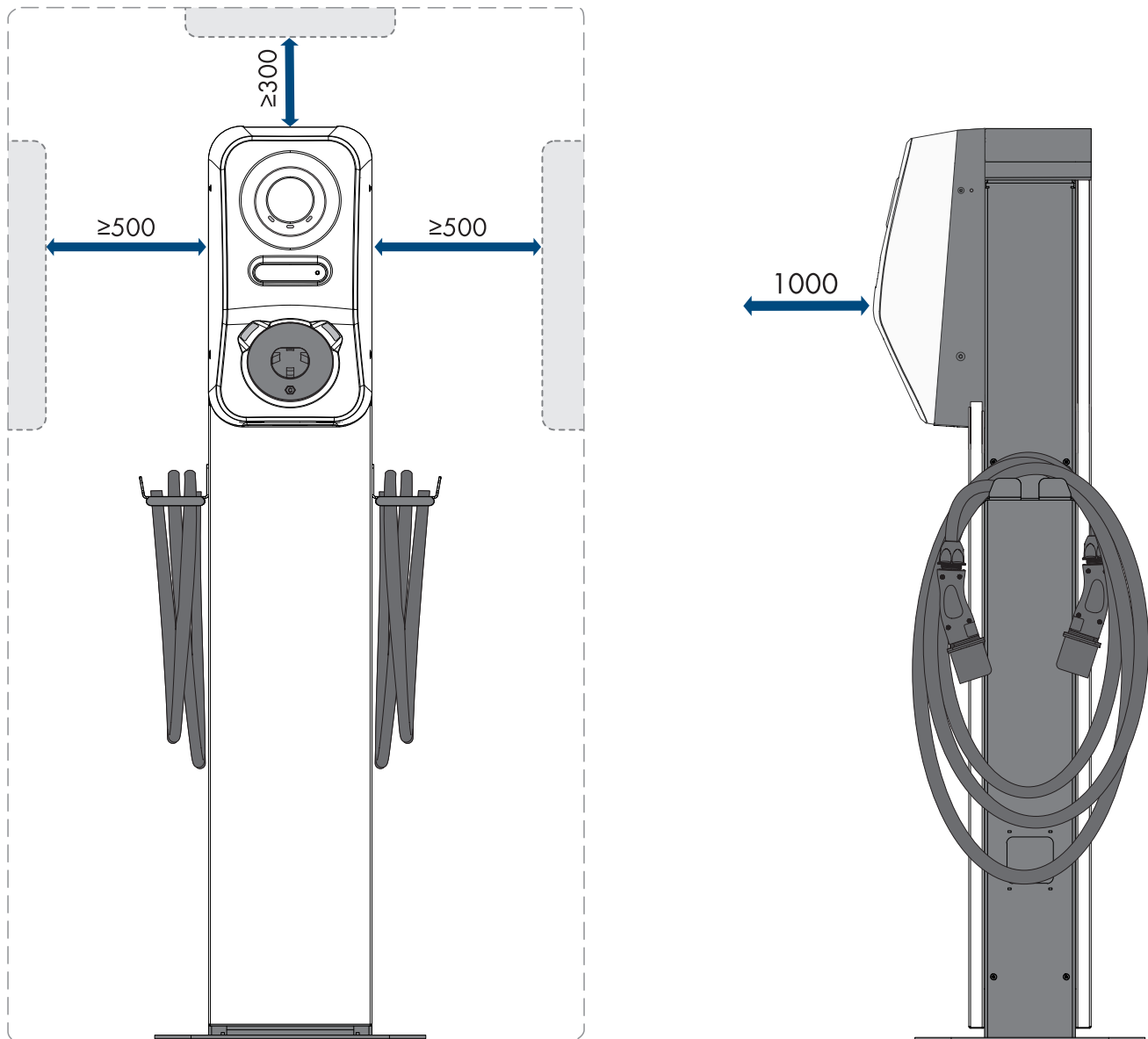

Figure 15: Recommended clearances (Dimensions in mm)

6.2 Wall Mounting

⚠ QUALIFIED PERSON

Requirements (not included in the scope of delivery):

- Prior to installing the wall mounting bracket, consider the possible cable route
- Four screws (6 mm diameter) suitable for the support surface and the weight of the charging station
- 4 washers suitable for the screws
- Where necessary, 4 screw anchors suitable for the support surface and the screws

⚠ CAUTION

Risk of injury due to weight of product

Injuries may result if the product is lifted incorrectly or dropped while being transported or mounted.

- Transport and lift the product carefully. Take the weight of the product into account.
- Wear suitable personal protective equipment for all work on the product.

Procedure:

1. Disconnect the miniature circuit breaker for all line conductors and secure against reconnection.
2. There are three options for routing the AC connection cable and the communication cable to the product (top, bottom, and rear). Decide on one option before drilling.

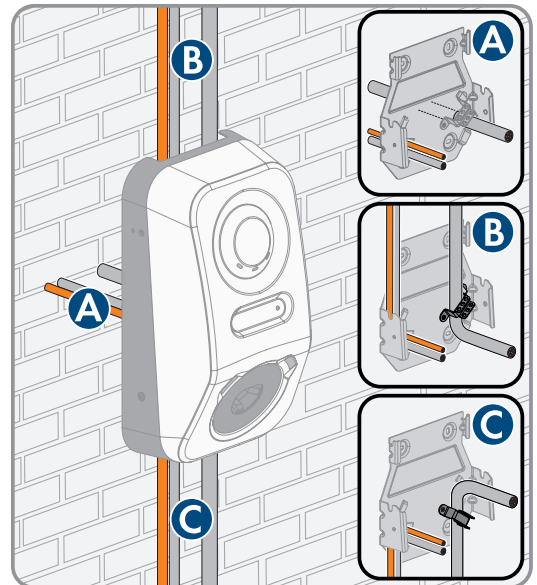

3. Align the wall mounting bracket horizontally on the wall and mark the position of the drill holes.
4. Set the wall mounting bracket aside and drill the marked holes.
5. Insert screw anchors into the drill holes if the support surface requires them.
6. For **option A**, run the AC connection cable and the communication cable through the wall mounting bracket and position the wall mounting bracket above the drilled holes.

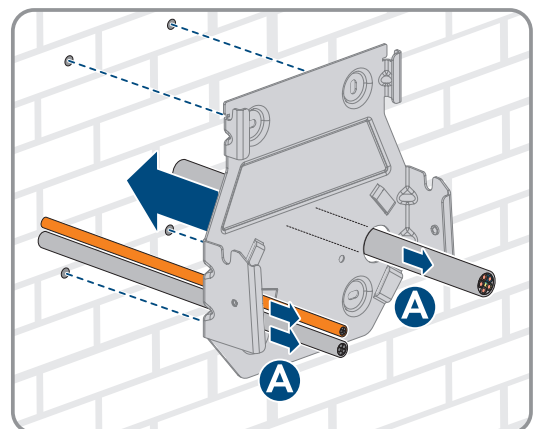

7. Secure the wall mounting bracket horizontally using screws and washers.

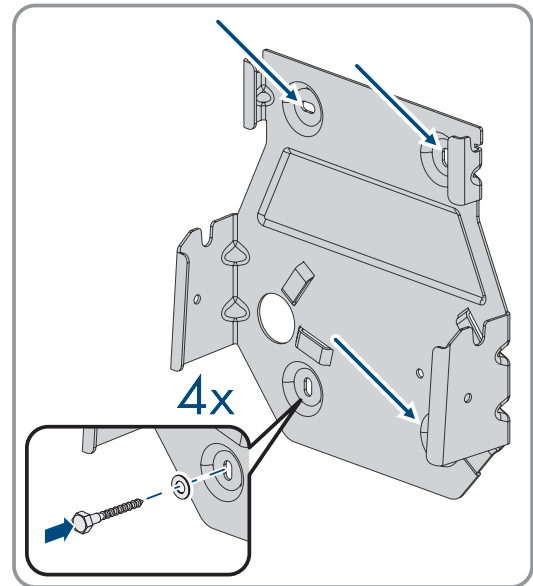

8. For **option B**, run the AC connection cable through the provided strain relief from above. Secure the strain relief using the included screw (M5 x 8) (T25, 3.5 Nm tightening torque) and then attach the AC connection cable to the strain relief with a suitable cable tie.

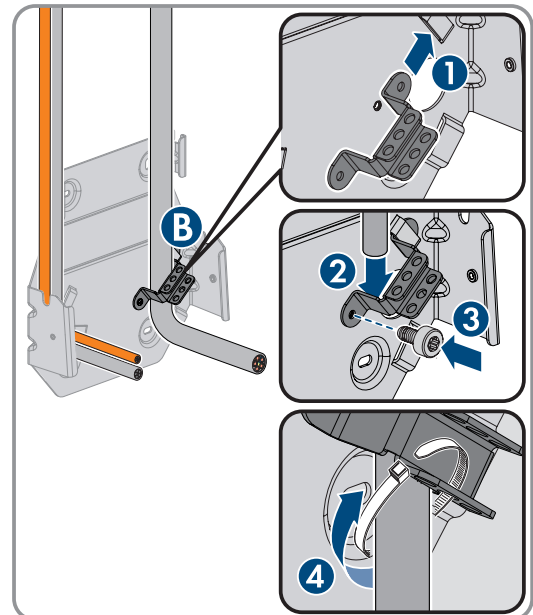

9. For **option C**, run the AC connection cable through the provided strain relief from below. Secure the strain relief using the included screw (M5 x 8) (T25, 3.5 Nm tightening torque) and then attach the AC connection cable to the strain relief with a suitable cable tie.

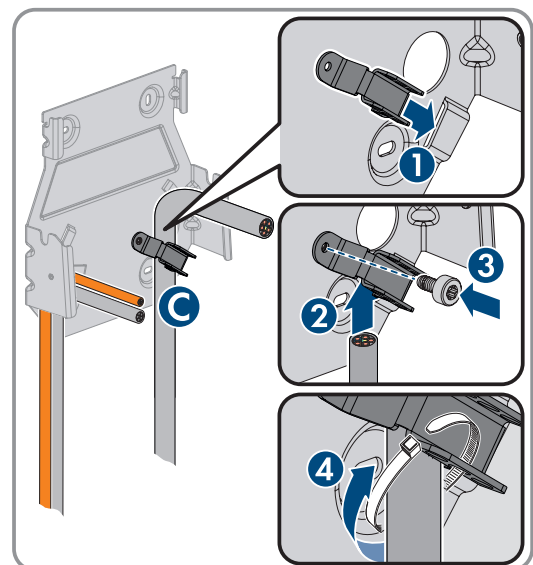

10. Cut the AC cable to 350 mm and the communication cable to about 490 mm.

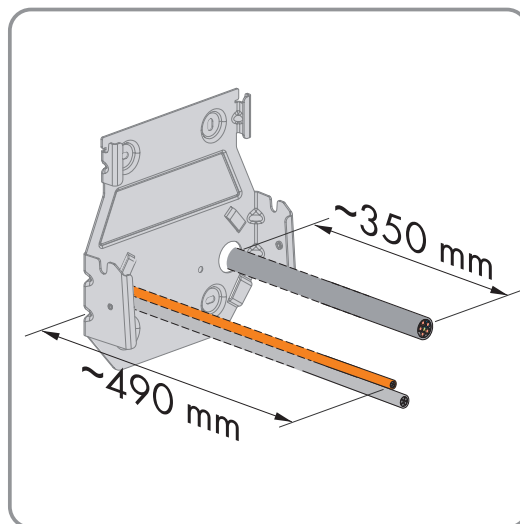

11. Release the locking tabs at the top of the cover of the enclosure with a suitable tool ($<\varnothing$ 5mm).

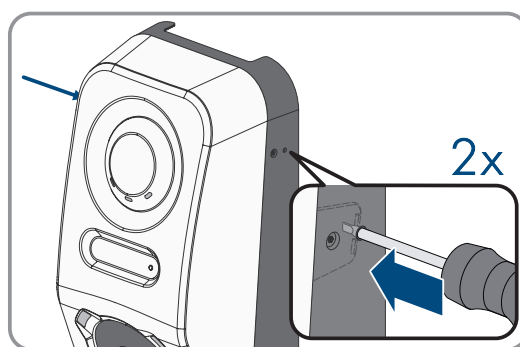

12. Tilt the cover forward to an angle of about 70° and then carefully pull upwards to remove it.

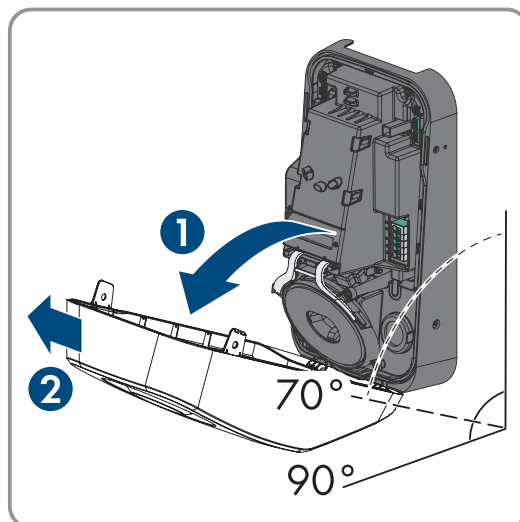

13. Remove the number of filler plugs needed to run the cables into the enclosure opening.

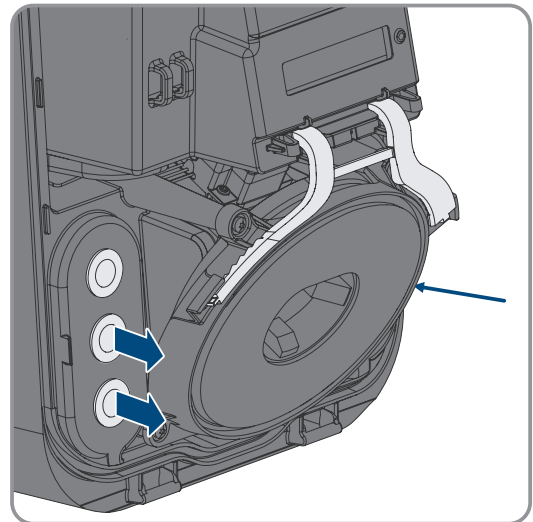

14. Run the AC cable through the enclosure openings on the right, and run the communication cable on the left.

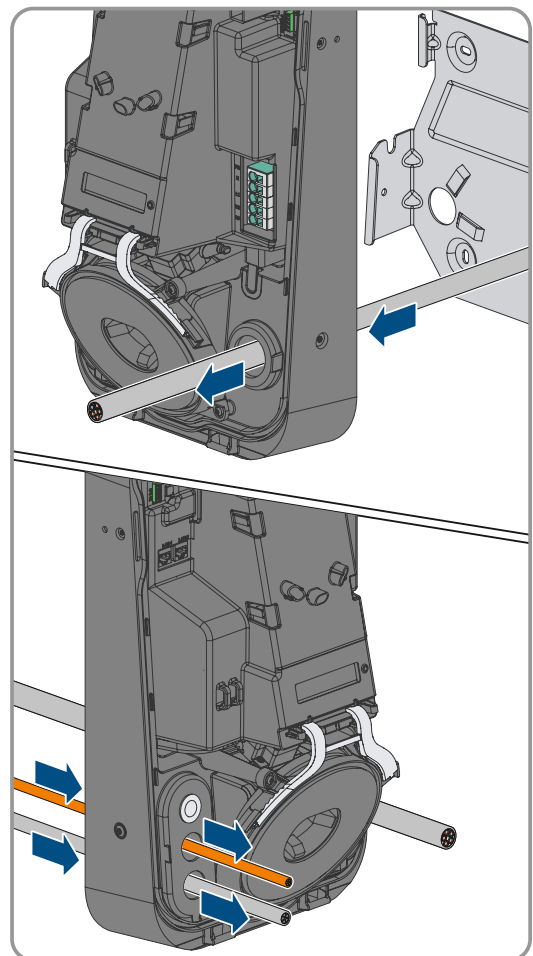

15. Place the enclosure horizontally on the wall mounting bracket and press it downward lightly.

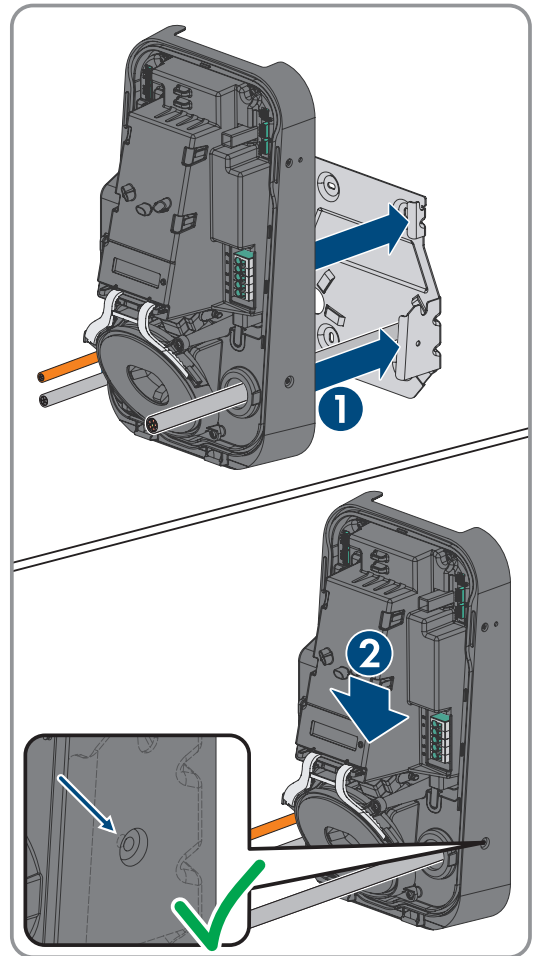

16. Make sure that the charging station is securely attached. The charging station is correctly hooked in when the indentations in the wall mounting bracket and the mounting tab line up.
17. Secure the enclosure on both sides with a flanged pan head screw (M5x12) provided. To do so, insert screws into the screw holes on the left and right sides of the enclosure and tighten them (TX25, tightening torque: 2.2 Nm).

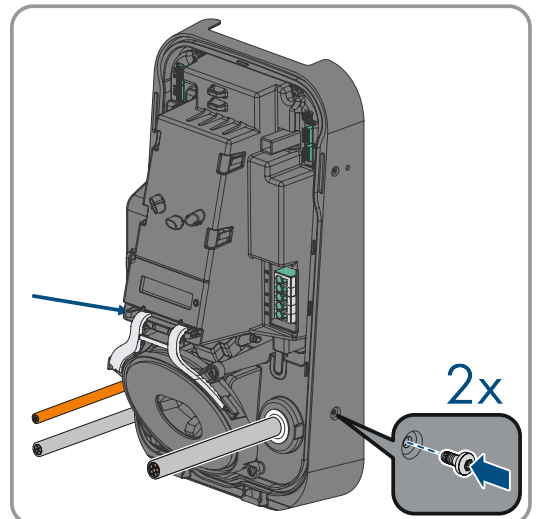

18. Use a suitable tool to puncture the filler plugs and run the AC cable and the communication cable through. Make sure that the filler plugs are in the right position and that no moisture can penetrate into the product.

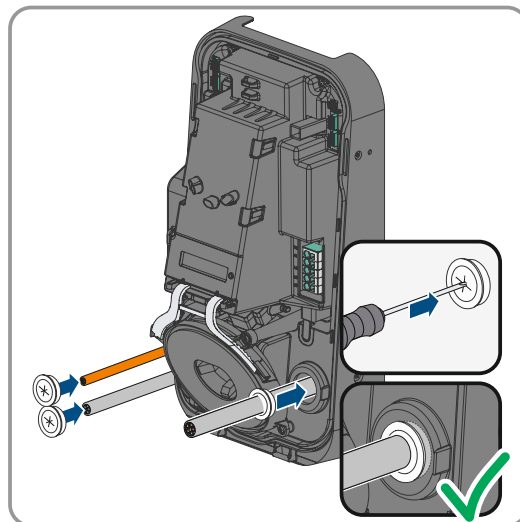

19. Make the electrical connection (see Section 7, page 53).

See also the following video for additional information:

TechTip: SMA eCharger Installation I DE



TechTip: SMA eCharger Installation I EN



6.3 Mounting the Charging Station Column

⚠ QUALIFIED PERSON

⚠ CAUTION

Risk of injury due to weight of product

Injuries may result if the product is lifted incorrectly or dropped while being transported or mounted.

- Transport and lift the product carefully. Take the weight of the product into account.
- Wear suitable personal protective equipment for all work on the product.

- i** For a concrete foundation produced by the operator, billing, design and production are exclusively the responsibility of the operator or the company that carried out mounting on behalf of the operator.

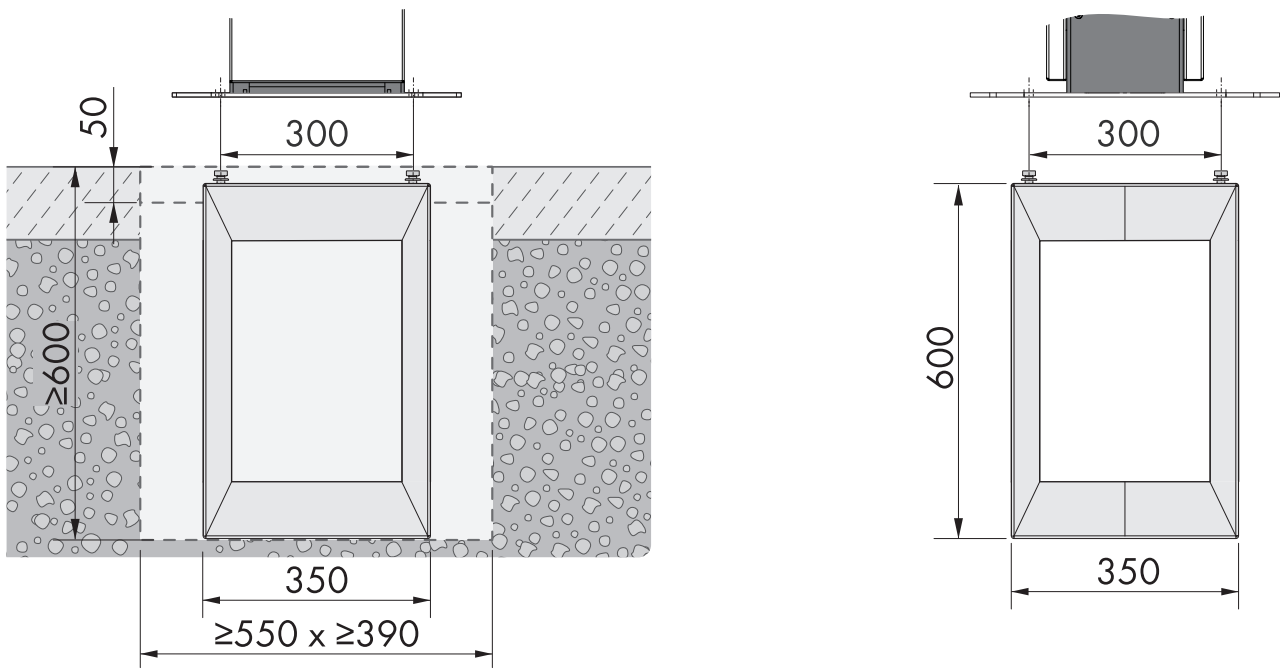
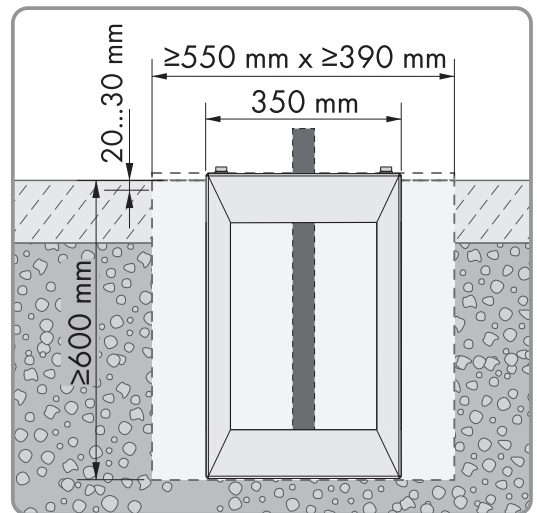

Figure 16: Dimensions of the foundation hole (dimensions in mm)

Procedure:

1. Ensure that the AC connection cable and communication cables are long enough to connect to the product.
2. Excavate the foundation hole with the following dimensions: width ≥ 550 mm x height ≥ 600 mm x depth ≥ 390 mm.



3. Insert the AC cable and communication cables upward through the opening in the embedded section into the hole.

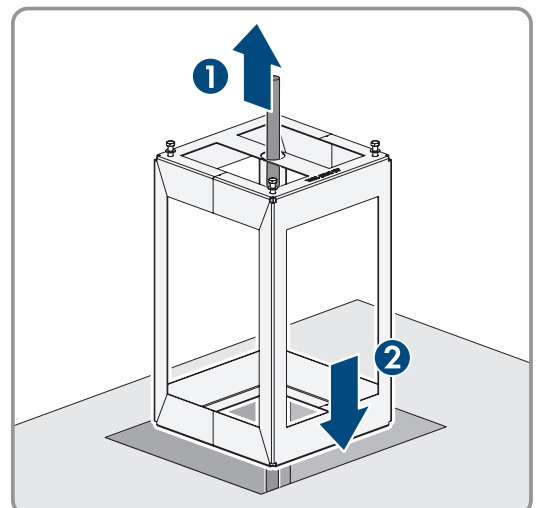

4. Stabilize the embedded section of the charging station column using class C30/37 concrete.

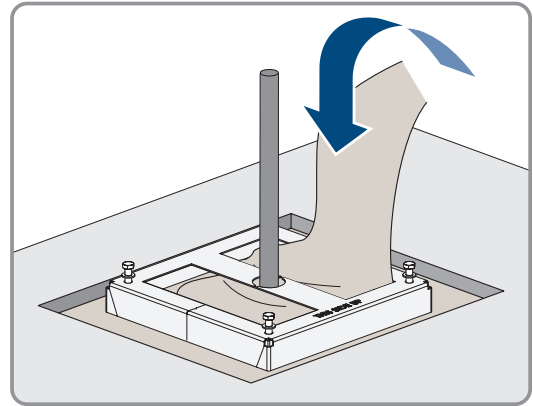

5. Let the concrete completely cure before starting to assemble the charging station column.
 6. Remove the 4 screws (M10) with the 4 washers from the embedded section.
 7. Position the base plate on the 4 holes of the embedded section of the charging station column. Secure the base plate with the 4 screws (M10x20) and the 4 (M10) washers (AF16).

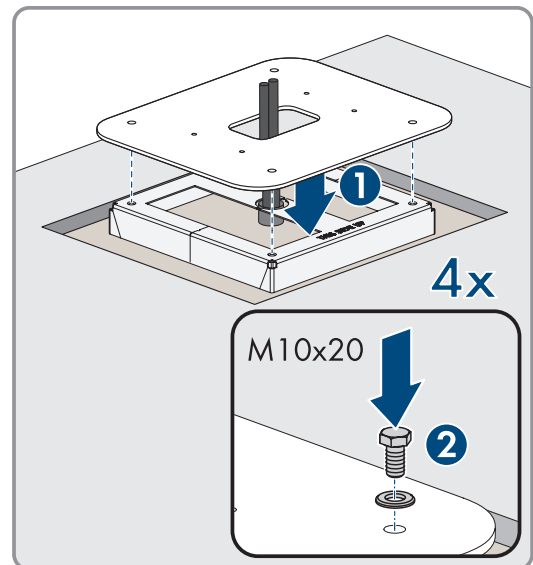

8. **Optional:** You can also directly fasten the base plate to a suitable support surface. To do so, drill 4 holes and secure the base plate using 4 heavy-duty anchors (M10x108, not in the scope of delivery) (AF16).

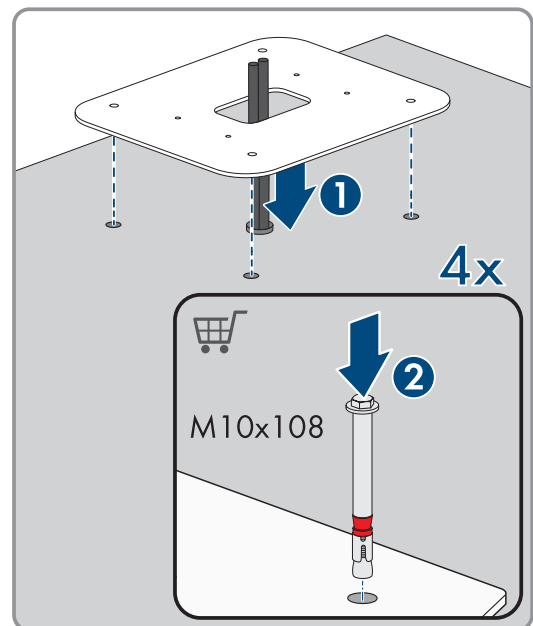

9. When putting on the middle section, guide the AC cable and communication cables through the middle section of the charging station column. Position the middle section on the 4 holes in the base plate. Pay attention to the weight.

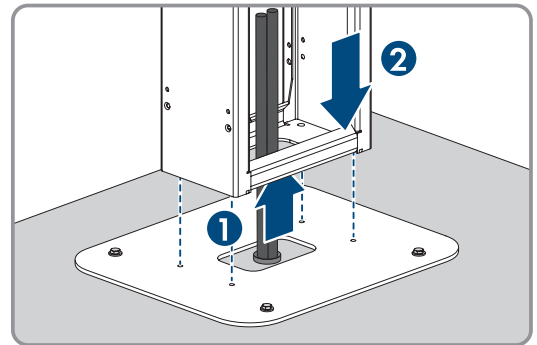

10. Use the 4 screws (M8x12) and 4 washers (M8) to secure the middle section of the charging station column (AF13, tightening torque: 25 Nm).

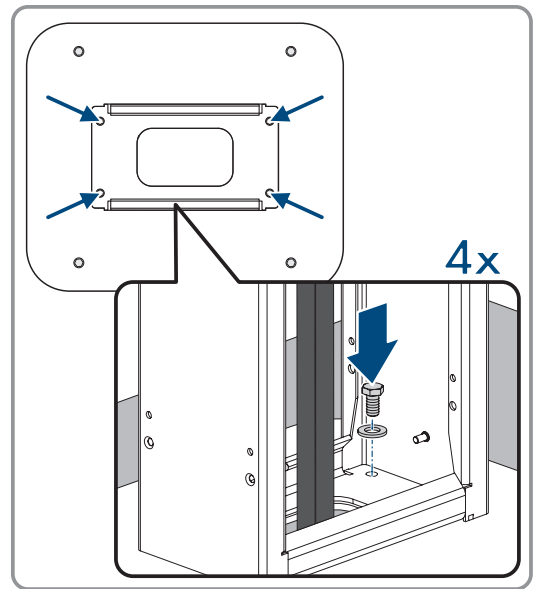

11. **Additional ground:** Connect the grounding conductor to the grounding bolts of the charging station column. Secure the crimped terminal lug to the grounding bolts. To do so, use the washer (M6), serrated lock washer (M6) and nut (M6) in the scope of delivery of the charging station column.

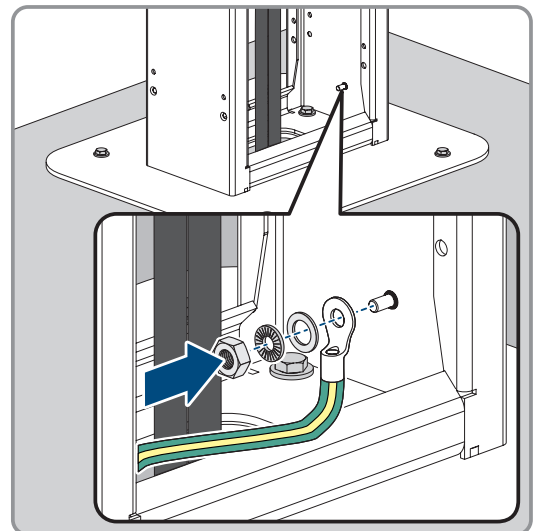

12. Use the 4 screws (M5x10) and 4 washers (M5) to secure the lid of the charging station column.

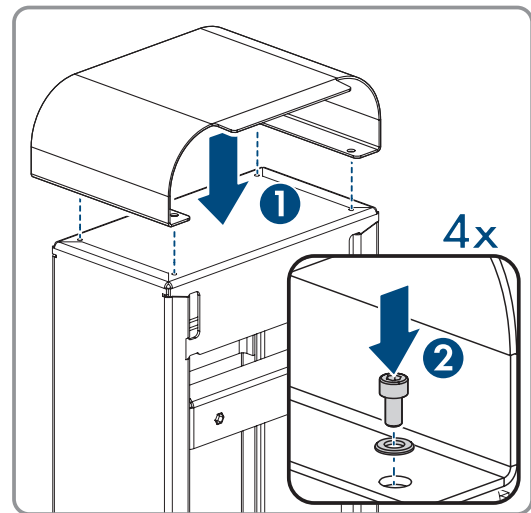

13. **Optional:** You can attach an AC distribution box (width 200 mm, height 200 mm, depth 122 mm) to the middle section of the charging station column at the specified position.

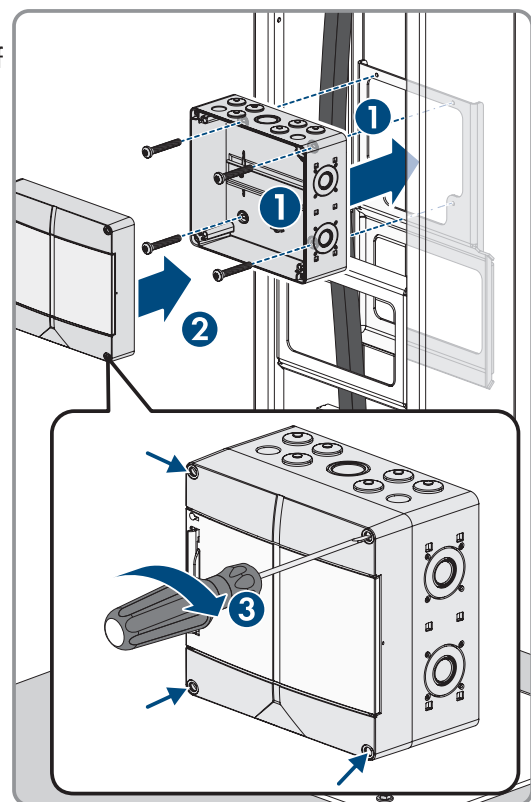

14. **Optional:** You can attach a socket (IP44 / width 75 mm, height 75 mm, depth 58 mm) to the side of the middle section of the charging station column at the specified position.

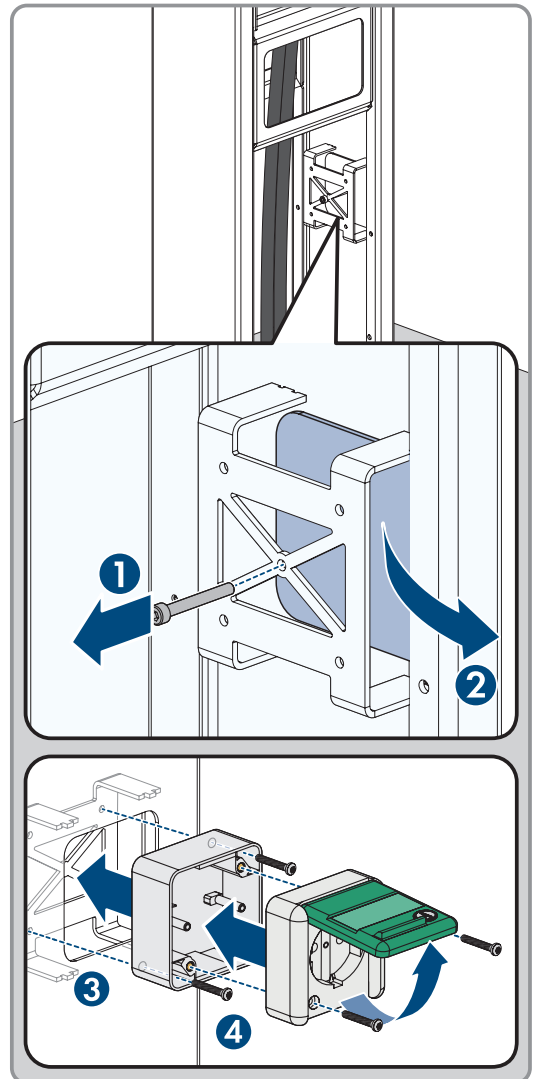

15. Attach the wall mounting bracket (included with the charging station) using the 4 screws (M6x14) and 4 washers (M6) included with the charging station column.

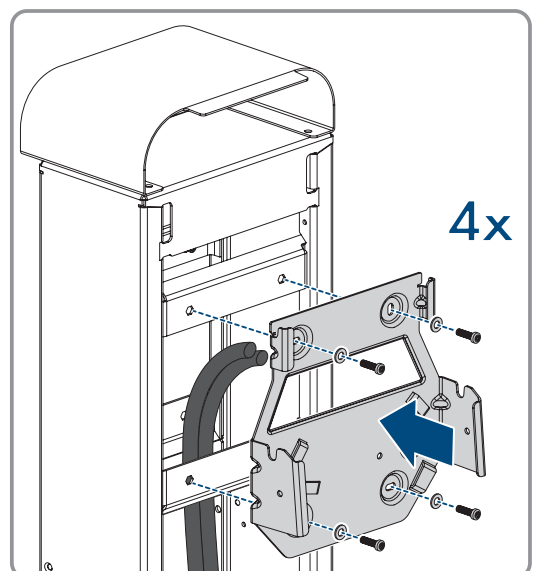

16. Feed the AC connection cable through the right opening and the communication cables through the left opening from the rear through the wall mounting bracket.

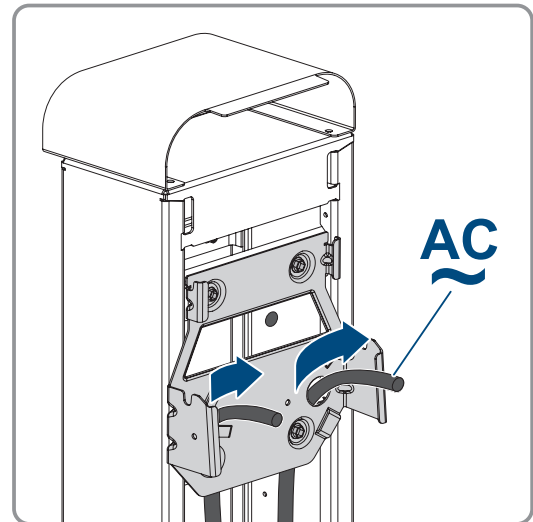

17. Complete the remaining assembly steps (see Section 6.2, page 38).

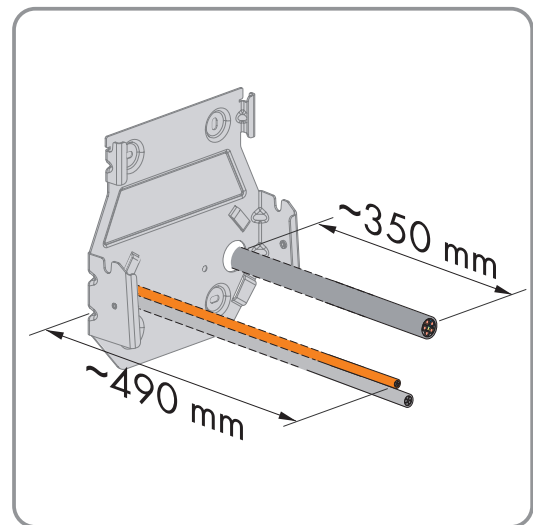

18. Make the electrical connection (see Section 7, page 53).

19. Hook the cover at the front and rear of the middle section of the charging station column. In the middle section of the charging station column, there are two carrier pins onto which the covers must be hooked.

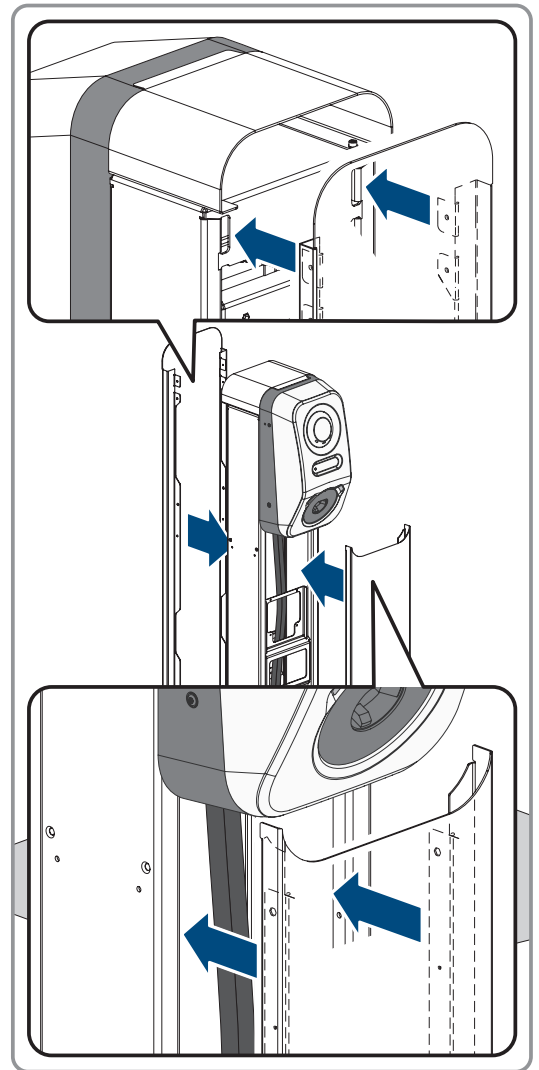

20. Secure the two covers from the side with the 8 screws (M5x40) in the scope of delivery of the charging station column (TX25, tightening torque: 5 Nm).

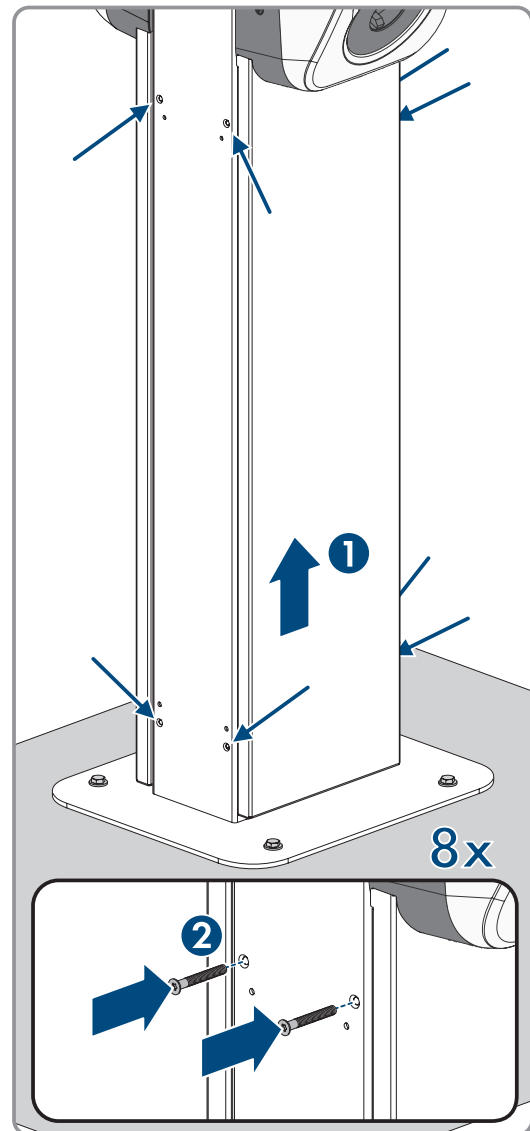

21. Lock the covers. To do so, insert a screwdriver through the opening and rotate the set screw counterclockwise until the stop (TX25, tightening torque: 5 Nm). Repeat the procedure at the remaining 3 positions.

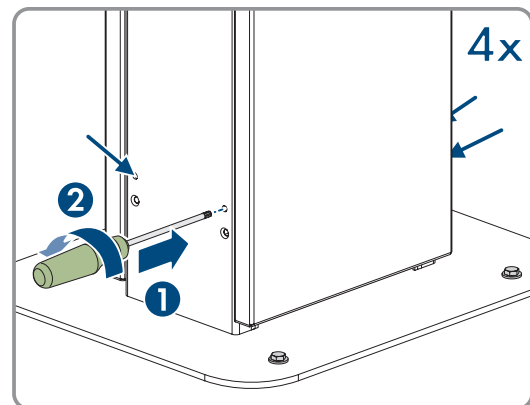

22. Attach the cable holder to the charging station column (M6x10). Seal all unused openings with the sealing plugs.

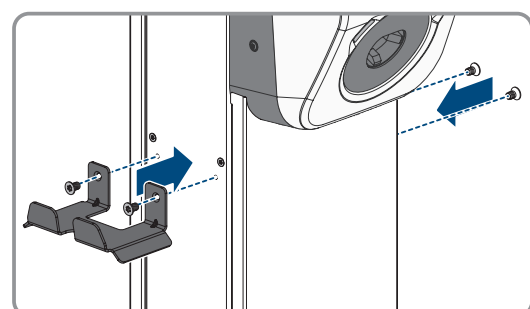

7 Electrical Connection

7.1 Requirements for the electrical connection

7.1.1 Permitted grid configurations

The charging station is approved for operation in the following utility grids:

TN-C system

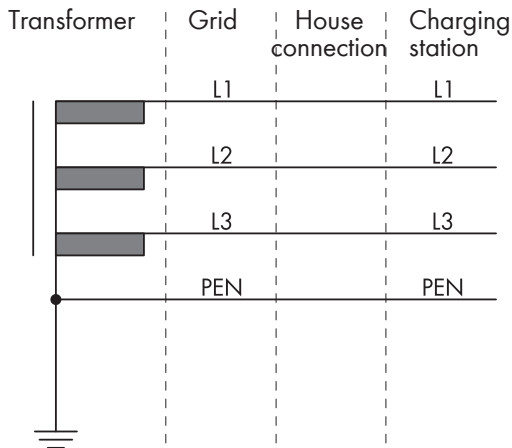

TN-S system

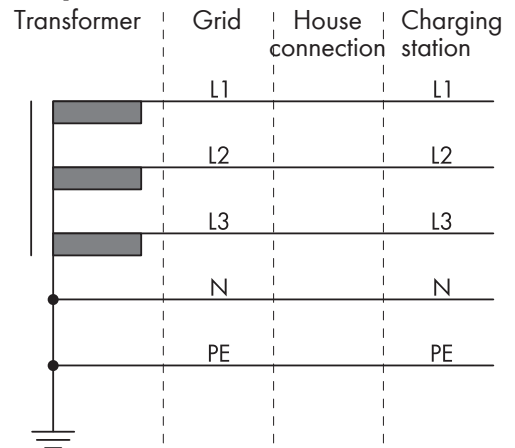

TN-C-S grid configuration

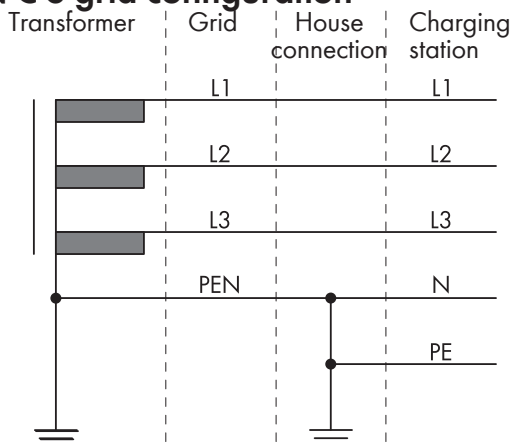

TT system

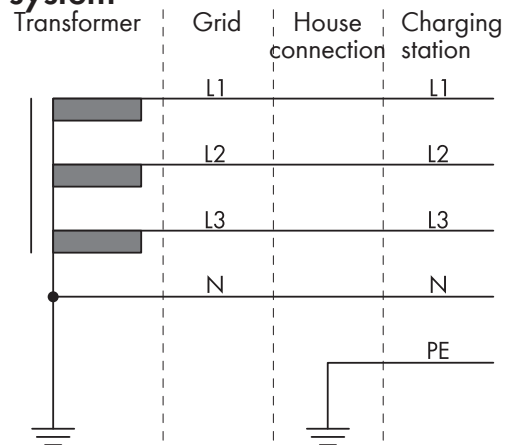

IT system

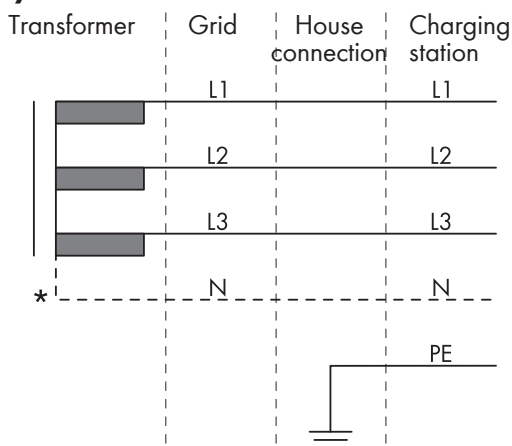

Delta-IT system

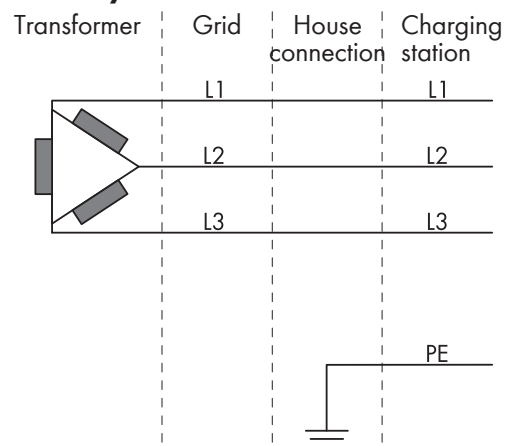

- TN-C
- TN-S
- TN-C-S
- TT
- IT
- Delta-IT (**Information:** When connected to the Delta-IT system, a maximum of 14,720 watts is available)

See also "Compatibility between common grid configurations and SMA inverters and SMA charging stations".

7.1.2 Residual-current monitoring unit

The charging station has an integrated DC residual-current device rated at 6 mA. The charging station does not need any external residual-current device for operation. If local regulations require the use of a residual-current device, the following must be observed:

- The charging station is compatible with residual-current devices of type A that have a rated residual current of 30 mA or higher. Each charging station in the system must be connected to the utility grid via a separate residual-current device.

7.1.3 Load-break switch and cable protection

NOTICE

Damage to the charging station due to the use of screw-type fuses as load-break switches

Screw-type fuses (e.g. DIAZED fuse or NEOZED fuse) are not load-break switches.

- Do not use screw-type fuses as load-break switches.
- Use a load-break switch or circuit breaker as a load disconnection unit (for information and design examples, see the Technical Information "Miniature circuit breaker" at www.SMA-Solar.com).

- In systems with multiple charging stations, protect each charging station with a separate circuit breaker. Make sure to observe the maximum permissible fuse protection (see Section 17, page 123). This will prevent residual voltage from being present at the corresponding cable after disconnection.
- LoLoads installed between the charging station and the circuit breaker must be fused separately.
- The overcurrent protective device for the AC output circuit is to be provided by others.

7.1.4 Overvoltage category

The product can be used in grids of overvoltage category III or lower in accordance with IEC 60664-1. That means that the product can be permanently connected to the grid-connection point of a building. In case of installations with long outdoor cabling routes, additional measures to reduce overvoltage category IV to overvoltage category III are required (see the Technical Information "Overvoltage Protection" at www.SMA-Solar.com).

7.1.5 AC cable requirements

- Conductor type: copper wire
- The conductors must be solid or fine-stranded. When using fine-stranded wire, bootlace ferrules can be used.
- Outer diameter: 14 mm to 25 mm
- Conductor cross-section of grounding conductor: 2.5 mm² to 10 mm² (rigid) / 2.5 mm² to 6 mm² (flexible)
- Conductor cross-section of line conductor and neutral conductor: 2.5 mm² to 10 mm² (rigid) / 2.5 mm² to 6 mm² (flexible)
- Insulation stripping length: 18 mm to 20 mm
- Sheath stripping length: about 100 mm

- The cable and conductor cross-sections must always be dimensioned according to the local and national directives and within the range specified by the manufacturer (SMA Solar Technology AG). If the manufacturer (SMA Solar Technology AG) requires a higher conductor cross-section than the standard, the range of the manufacturer must be observed. Examples of factors influencing cable dimensioning are: nominal AC current, type of cable, routing method, cable bundling, ambient temperature and maximum desired line losses (for calculation of line losses, see the design software "Sunny Design" from software version 2.0 at www.SMA-Solar.com).

7.1.6 Network cable requirements

The cable length and quality affect the quality of the signal. Observe the following cable requirements:

- Cable type: 100BaseTx
- Cable category: minimum CAT5e
- Plug type: RJ45 of Cat5, Cat5e or higher with metal enclosure
- Shielding: SF/UTP, S/UTP, SF/FTP or S/FTP
- Number of insulated conductor pairs and insulated conductor cross-section: at least 2 x 2 x 0.22 mm²
- Maximum cable length between two nodes when using patch cables: 50 m
- Maximum cable length between two nodes when using installation cables: 100 m
- UV-resistant if installed outdoors.

7.1.7 Signal cable requirements

The cable length and quality affect the quality of the signal. Observe the following cable requirements:

- Conductor cross-section: 0.5 mm² to 0.75 mm²
- External diameter: Max. 8 mm
- Maximum cable length: 100 m
- Insulation stripping length: 6 mm
- Sheath stripping length: 150 mm
- UV-resistant for outdoor use
- The cable type and cable-laying method must be appropriate for the application and location.

7.1.8 Requirements for the RS485 interface

The product is suitable for the communication with RS485 devices via Modbus RTU.

The interface parameters must be set as follows:

Set-up:	8 data bits
	1 stop bit
	no parity

Cable requirements:

The cable length and quality affect the quality of the signal. Observe the following cable requirements.

- Number of insulated conductor pairs and insulated conductor cross-section: at least 2 x 2 x 0.22 mm²
- Maximum cable length across the entire RS485 bus: 1200 m
- Twisted pair conductors
- Cable with shielding: Yes
- UV-resistant if installed outdoors.

7.2 Overview of the Connection Area

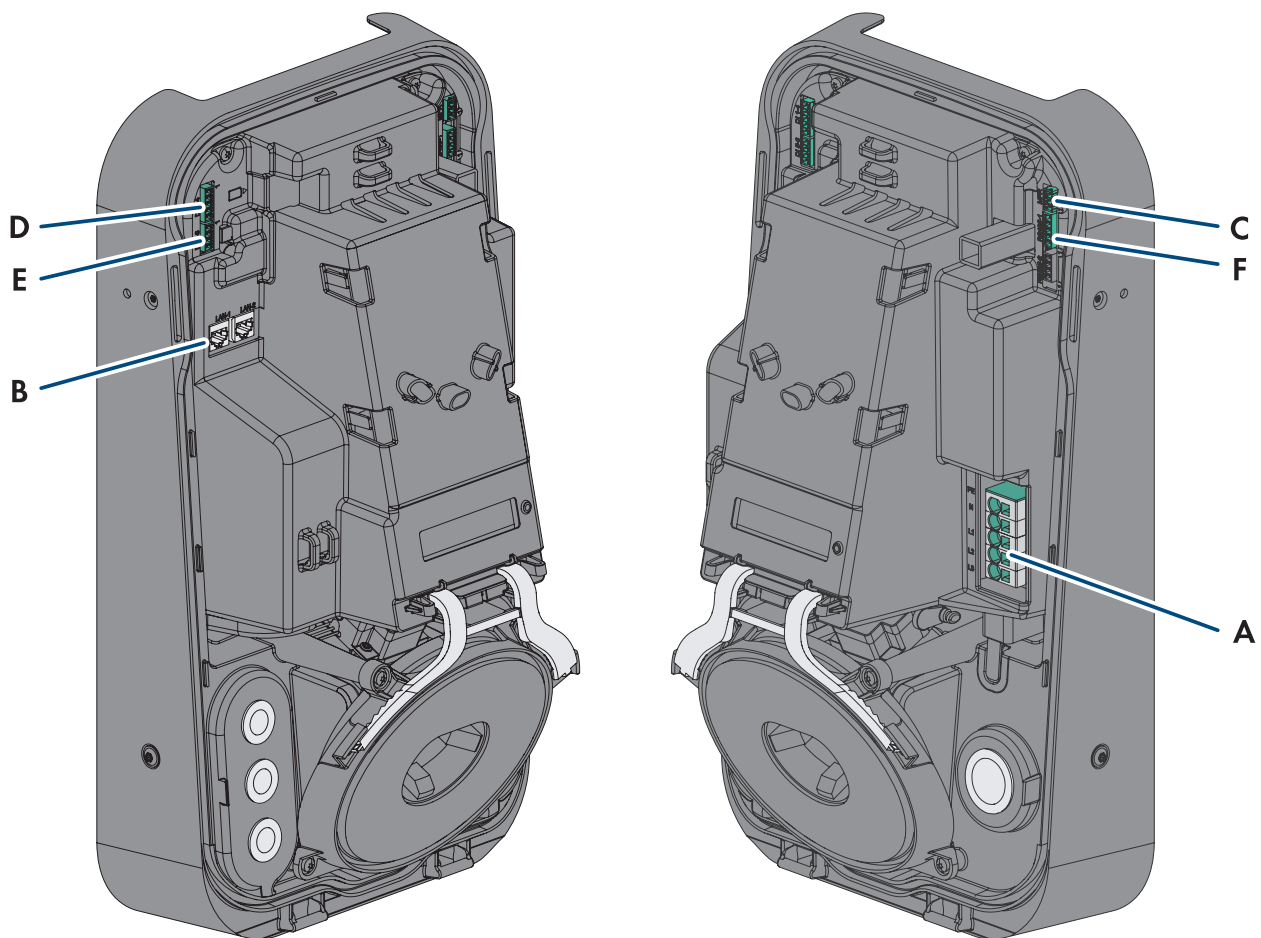

Figure 17: Connection areas in the interior of the product

Position	Designation
A	Terminal block for the AC connection cable
B	Network ports (LAN1 and LAN2)
C	MFR slot for connection to the multifunction relay
D	Slot DI 1-4 for connecting a ripple control receiver
E	Slot DI 5-6 for connecting digital signal sources
F	RS485 slot for connecting SMA-compatible RS485 devices

7.3 Electrical connection procedure

⚠ QUALIFIED PERSON

This section describes the procedure for the electrical connection of the product. It provides an overview of the steps, which must be performed in the prescribed sequence.

Procedure	See
1. Ensure that the requirements for the electrical connection are fulfilled	Section 7.1, page 53

Procedure	See
2. Connect the AC cable	Section 7.4.3, page 59
3. Connecting the Network Cables	Section 7.5, page 61
4. Connecting the Ripple Control Receiver	Section 7.6, page 62
5. Connecting the multifunction relay	Section 7.8, page 66
6. Connecting the digital inputs DI 5-6	Section 7.7, page 64
7. Connecting to the RS485 interface	Section 7.9, page 68
8. Close the enclosure cover.	Section 7.10, page 70

7.4 Connecting the Utility Grid

7.4.1 Multi-EVC operation

Multi-EVC operation allows you to connect up to three SMA eChargers. In multi-EVC operation mode, all charging stations must be connected to the utility grid on a rolling basis.

The Sunny Home Manager provides the charging stations with information on the number of active charging stations every minute.

In multi-EVC operation mode, if multiple charging stations are charging vehicles and there is a two-phase charging vehicle among the vehicles, this vehicle is limited to single-phase charging for symmetry reasons.

If communication between Sunny Home Manager and the charging stations fails, only single-phase or three-phase charging vehicles can be charged. Two-phase charging vehicles are also limited to single-phase charging in this case. You can set fallback values that take effect in the event of a communication breakdown.

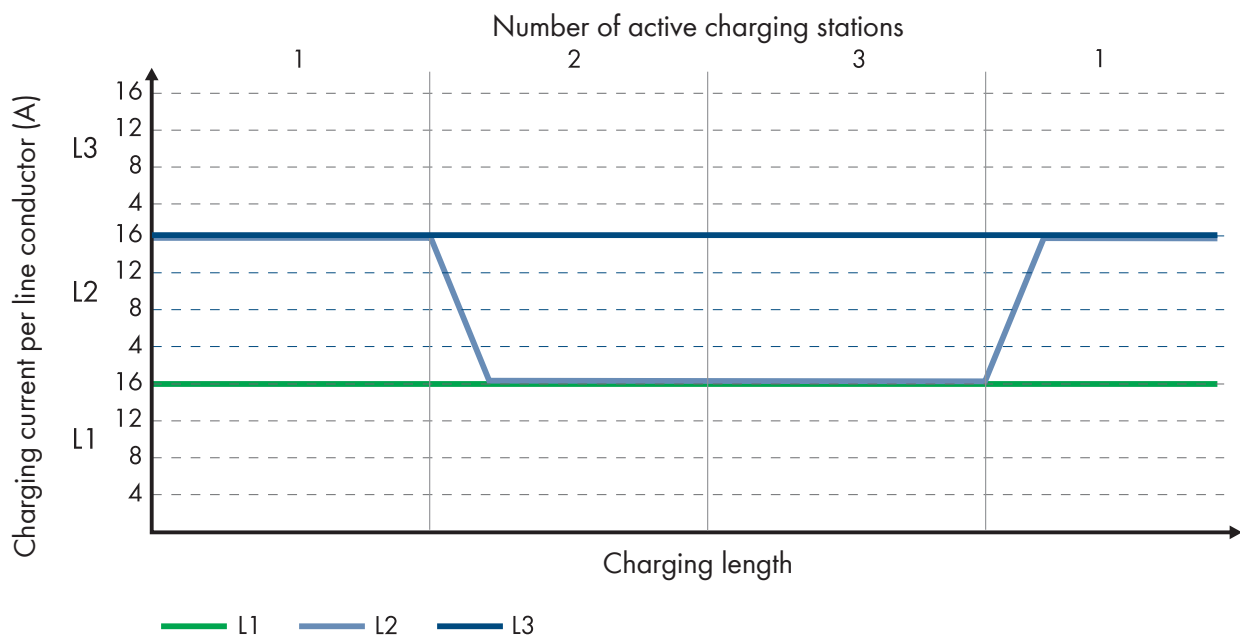

Figure 18: Two-phase charging electric vehicle at SMA eCharger

In multi-EVC mode, the maximum charging current is limited to ensure overload protection (maximum charging current/number of active charging stations). If, for example, 3 charging stations are connected to a point of interconnection with a nominal current of 35 A, the charging current is limited as follows:

- 1 active charging station: 32 A
- 2 active charging stations: 17.5 A per charging station

- 3 active charging stations: 11.67 A per charging station

Note that loads with high power consumption can cause the charging stations to disconnect from the utility grid to ensure overload protection.

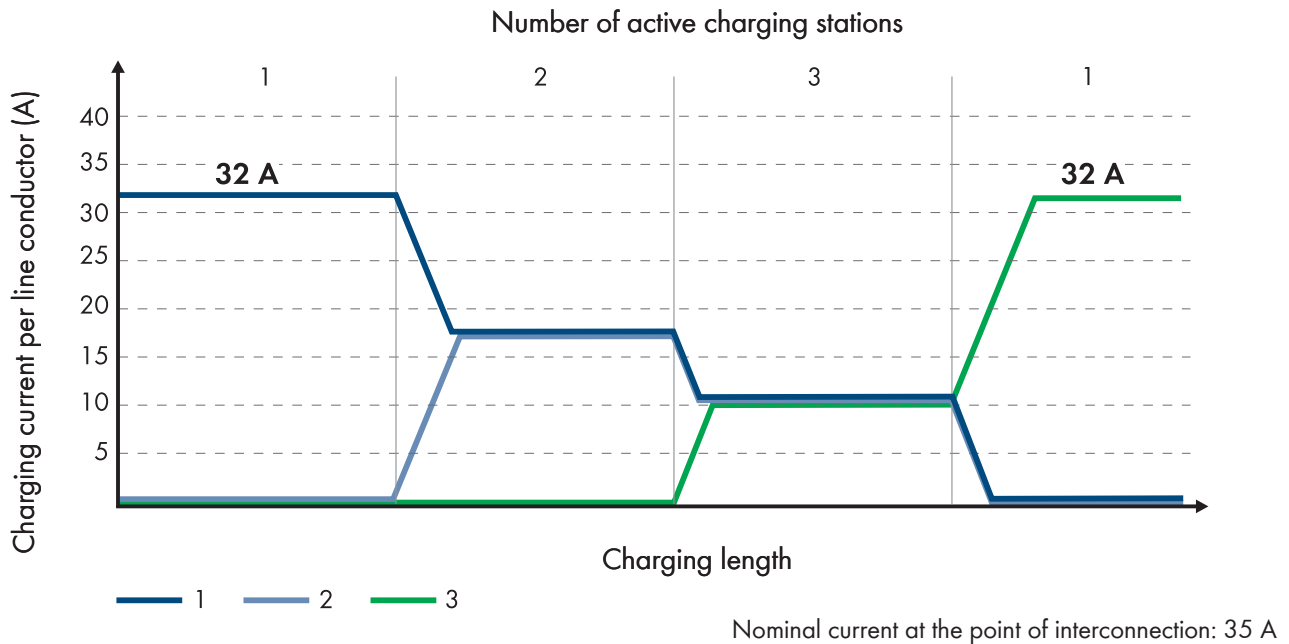

Figure 19: Charge current limitation

7.4.2 Multi-EVC operation

⚠ QUALIFIED PERSON

In multi-EVC operation mode, all charging stations must be connected to the utility grid on a rolling basis (see Section 5.2.4, page 23). A system with 3 three-phase charging stations must be connected to the utility grid on a rolling basis as follows:

- Three-phase charging station 1: L1, L2, L3
- Three-phase charging station 2: L2, L3, L1
- Three-phase charging station 3: L3, L1, L2

For example, a system with 2 three-phase charging stations and 1 single-phase charging station can be connected as follows:

- Three-phase charging station 1: L1, L2, L3
- Three-phase charging station 2: L2, L3, L1
- Single-phase charging station 3: L3

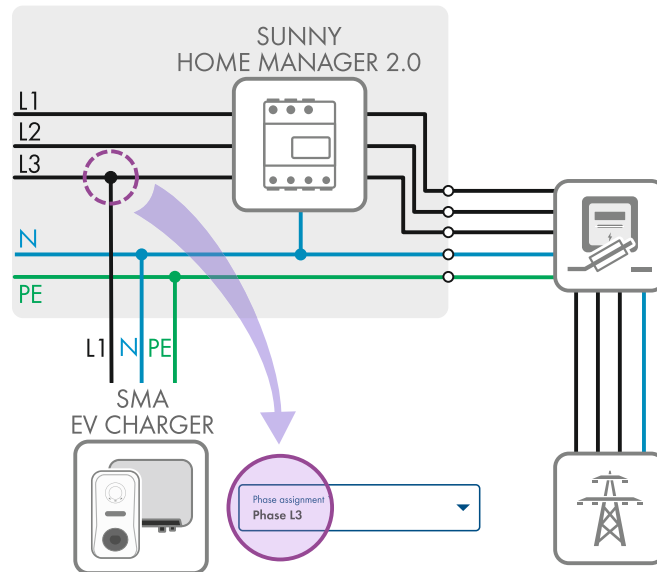

Figure 20: Phase assignment

7.4.3 Connecting the AC Cable

⚠ QUALIFIED PERSON

Requirement:

- The enclosure cover has been removed.

Procedure:

1. Disconnect the circuit breaker for all line conductors and secure against reconnection.
2. Dismantle the AC cable.
3. Strip off the conductor insulation by 18 mm to 20 mm each.
4. If necessary, provide each conductor with a bootlace ferrule.
5. Connect the **grounding conductor** according to the labeling.

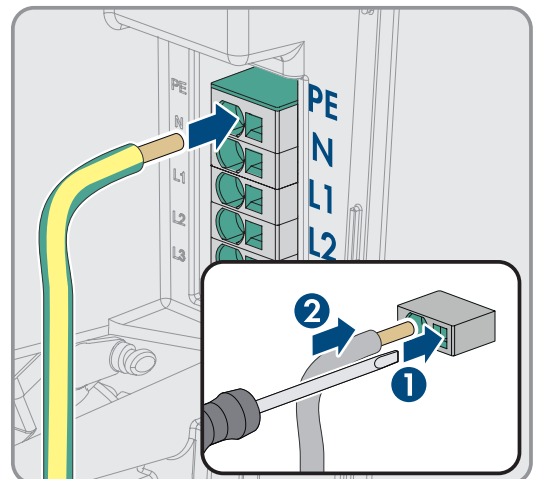

6. Connect **N** according to the labeling.

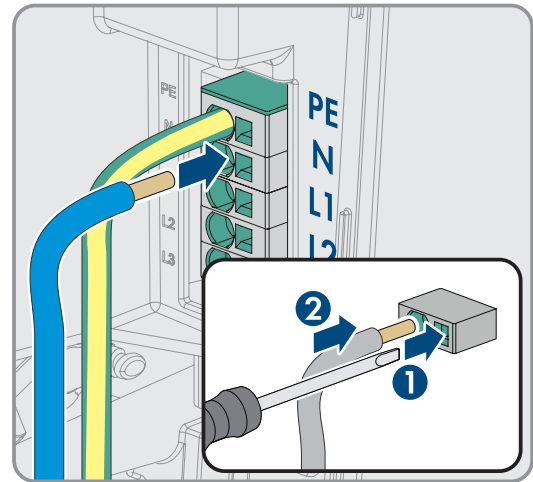

7. Depending on the requirements, connect the conductor **L1** according to the labeling.

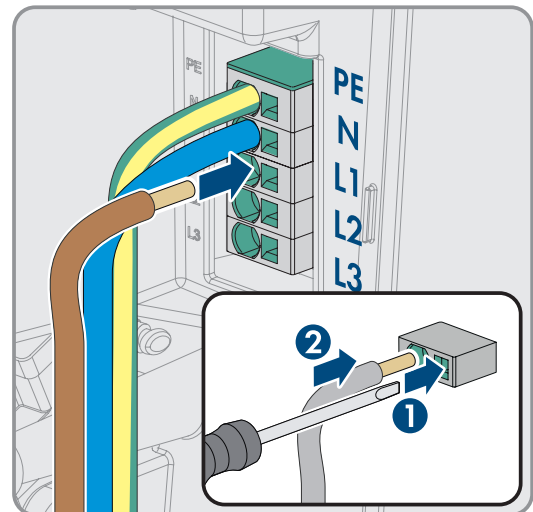

8. Depending on the requirements, connect the conductors **L1**, **L2**, and **L3** according to the labeling.

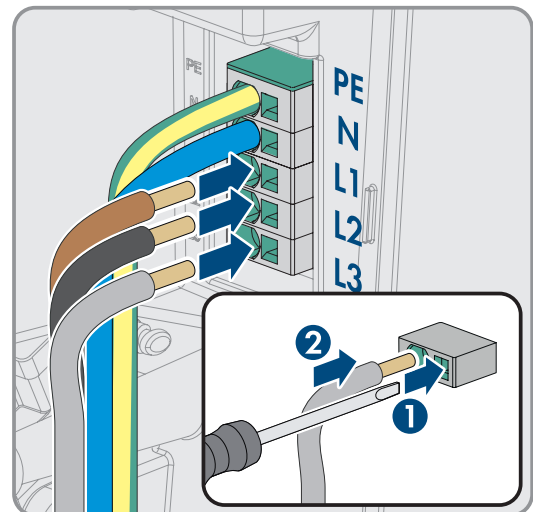

9. Ensure that the correct conductors are assigned to all the terminals.

10. Ensure that all conductors are securely in place.

Also see:

- [Overview of the Connection Area](#) ⇒ page 56

7.5 Connecting the Network Cables

⚠ QUALIFIED PERSON

⚠ DANGER

Danger to life due to electric shock in case of overvoltages and if surge protection is missing

Overvoltages (e.g., in the event of a flash of lightning) can be further conducted into the building and to other connected devices in the same network via the network cables or other data cables if there is no surge protection. Touching live parts and cables results in death or lethal injuries due to electric shock.

- Ensure that all devices in the same network are integrated in the existing overvoltage protection.
- When laying the network cable outdoors, ensure that there is suitable surge protection at the network cable transition from the product outdoors to the network inside the building.
- The Ethernet interface of the product is classified as "TNV-1" and offers protection against overvoltages of up to 1.5 kV.

i The two LAN ports (LAN1 and LAN2) enable multiple SMA devices to be connected in series (daisy chain) to the network.

Additionally required material (not included in the scope of delivery):

- Network cables (see Section 7.1.6, page 55)
- Where required: Field-assembly RJ45 connector.

Procedure:

1. Disconnect the charging station from voltage sources (see Section 10, page 99).
2. When using a self-assembly network cable, assemble the RJ45 connectors and connect them to each network cable (see connector documentation).
3. Insert each network cable into one of the network ports.

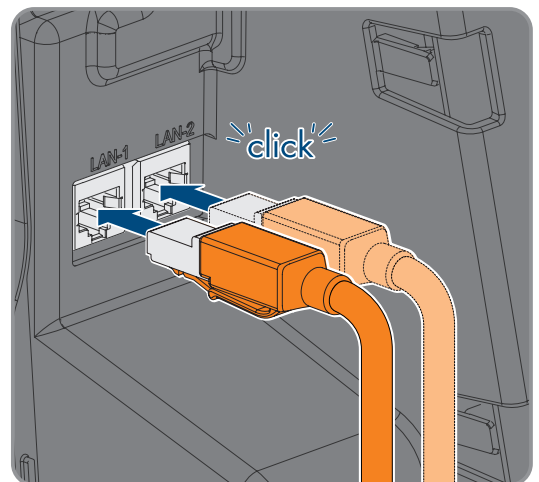

- Secure each network cable to a strut using a cable tie, and cut off the protruding end of the cable tie with diagonal cutting pliers.

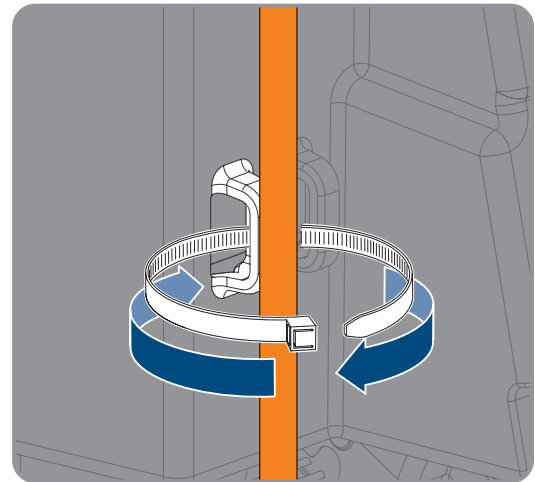

- Ensure that the network cables are securely in place by pulling slightly on them, and that the strain relief is effective.
- If the charging station is installed outdoors, install overvoltage protection for all components in the network.
- If you would like to integrate the charging station into a local network, connect the other end of a network cable to the local network (e.g. via a router).

7.6 Connecting the Ripple Control Receiver

7.6.1 Digital input DI 1-4

A ripple control receiver or remote terminal unit can be connected to digital input **DI 1-4**.

Information on EnWG §14a: Via the digital input, known as the grid operator interface, the SMA eCharger can actively respond to grid operator specifications to prevent grid overload and temporarily adjust the charging power to the corresponding specifications (in this specific case, 4.2 kW). The type of external control device (control box or ripple control receiver) is determined by the local grid operator.

7.6.2 Pin assignment DI 1-4

Digital input DI 1-4

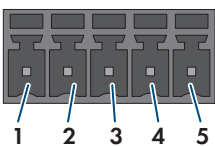

Pin	Assignment
1	Digital input 1
2	Digital input 2
3	Digital input 3
4	Digital input 4
5	Voltage supply output

7.6.3 Circuitry overview DI 1-4

SMA eCharger as System Manager

Ripple control receiver



Figure 21: Connect a ripple control receiver to digital input DI 1-4 of the SMA eCharger that is to be configured as System Manager

7.6.4 Connecting the ripple control receiver to DI 1-4

⚠ QUALIFIED PERSON

Procedure:

1. Connect the connection cable to the ripple control receiver or the remote terminal unit (see the manual from manufacturer).
2. Disconnect the charging station from voltage sources (see Section 10, page 99).
3. Strip 6 mm of the cable insulation at maximum.
4. Release the conductor entries on the supplied 5-pole plug.

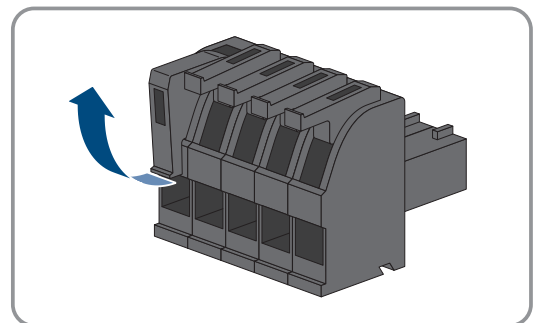

5. Connect the conductors of the connection cable to the supplied five-pole connector. To do so, plug the conductors into the conductor entries and close the conductor entries. Observe the connector assignment.

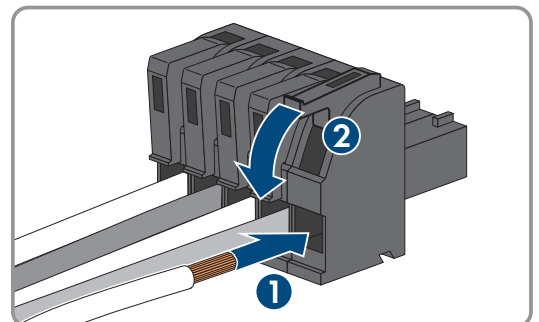

- Plug the five-pole connector into the port **DI 1-4** on the product. Observe the pin assignment.

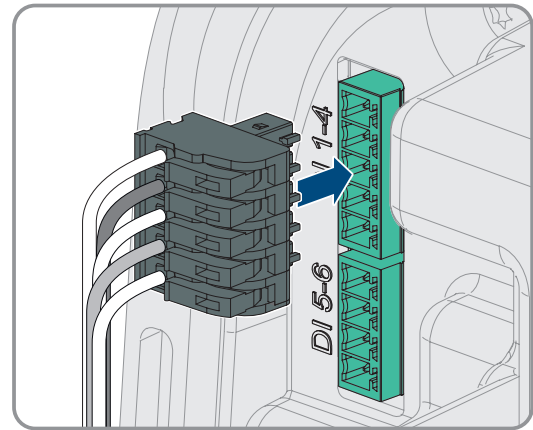

- Ensure that the connector is securely in place.
- Ensure that all conductors are correctly connected.
- Ensure that the conductors sit securely in the terminal points.

7.7 Connection to digital input DI 5-6

7.7.1 Digital input DI 5-6

You can connect a fast-stop switch at digital input **DI 5**.

You can connect a relay for an external grid and PV system protection device at digital input **DI 6**. In a system with multiple charging stations, each charging station must be connected to the relay.

7.7.2 Pin assignment DI 5-6

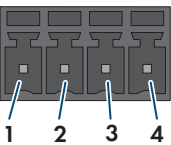
Digital input	Pin	Assignment
	1	Digital input 5
	2	Voltage supply: (+12 V)
	3	Digital input 6
	4	Voltage supply: (+12 V)

7.7.3 Circuitry overview DI 5

SMA eCharger as System Manager

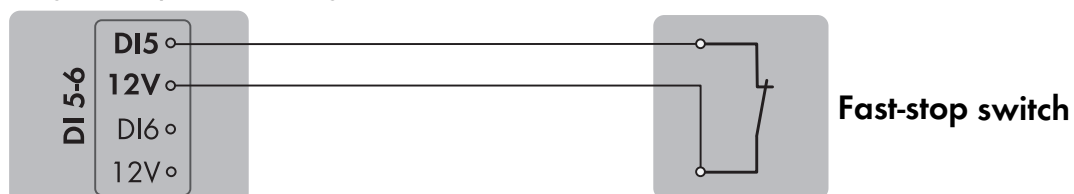

Figure 22: Connect a switch for the fast stop to digital input DI 5 of the charging station that is to be configured as System Manager

7.7.4 Circuitry overview DI 6

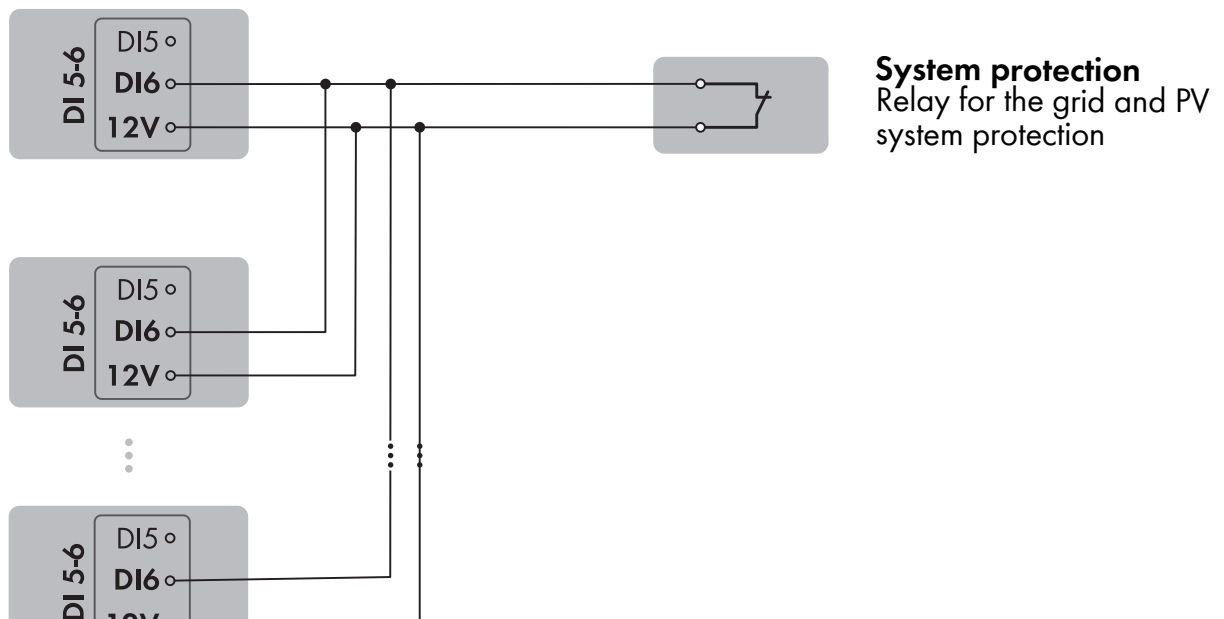

Figure 23: Connect a relay for the external grid and PV system protection device to digital input DI 6 of one or more charging stations in the system

7.7.5 Connecting Signal Source to Digital Input DI 5-6

⚠ QUALIFIED PERSON

Additionally required material (not included in the scope of delivery):

- 1 relay for the grid and PV system protection (break contact)
- 1 fast-stop switch (break contact)

Requirements:

- The signal source must be technically suitable for connection to the digital inputs (see Section 17, page 123).

Procedure:

1. Disconnect the charging station from voltage sources (see Section 10, page 99).
2. Connect the connection cable to the digital signal source (see the manual from manufacturer).
3. Run the cable to the **DI 5-6** slot.
4. Dismantle the cable by 150 mm.
5. Strip off the conductor insulation by 6 mm.
6. Unlock the conductor entries on the supplied four-pole connector.

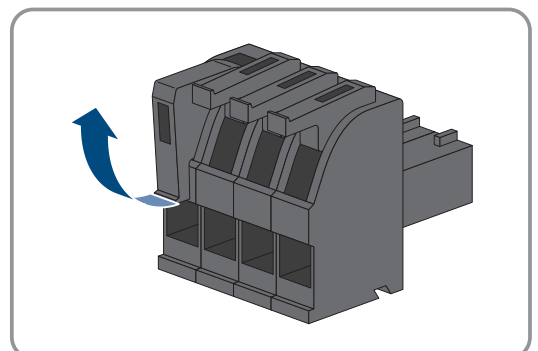

7. Connect the connection cable to the supplied four-pole connector. To do so, plug the conductors into the conductor entries and close the conductor entries. Observe the connector assignment.

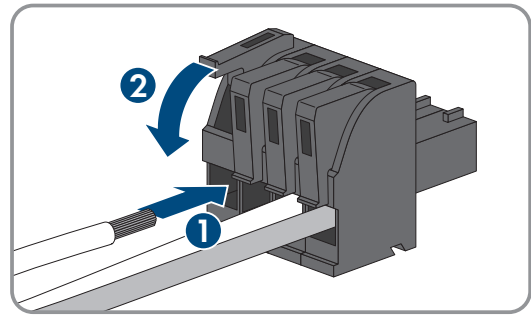

8. Plug the 4-pole connector into the port **DI 5-6** on the product. Observe the pin assignment.

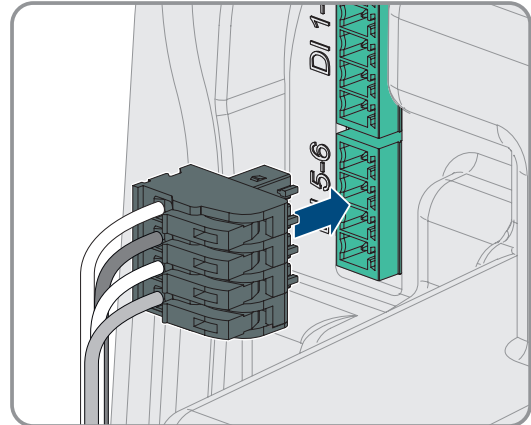

9. Secure the cable to a strut using a cable tie, and cut off the protruding end of the cable tie with a suitable tool.
 10. Ensure that the connector is securely in place.
 11. Ensure that all conductors are correctly connected.
 12. Ensure that the conductors sit securely in the terminal points.

Also see:

- [Signal cable requirements](#) ⇒ page 55

7.8 Connection to the Multifunction Relay

7.8.1 Digital output (MFR)

The multifunction relay (MFR) is a digital output that can be specifically configured to the system.

Also see:

- [Use of the digital output \(MFR\)](#) ⇒ page 87

7.8.2 Pin assignment MFR

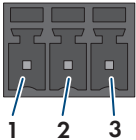
Digital input	Pin	Assignment
	1	NO
	2	CO
	3	NC

7.8.3 Connect signal source to MFR

⚠ QUALIFIED PERSON

Requirements:

- The technical requirements of the multifunction relay must be met (see Section 17, page 123).

Procedure:

1. Disconnect the charging station from voltage sources (see Section 10, page 99).
2. Run the cable to the **MFR** slot.
3. Strip 6 mm of the cable insulation at maximum.
4. Unlock the conductor inserts on the provided 3-pole connector.

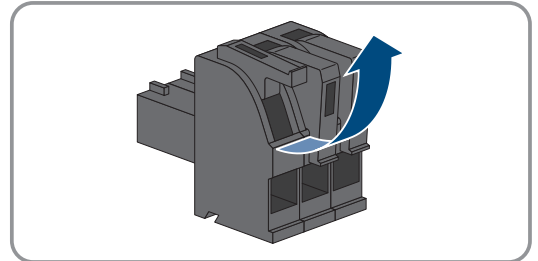

5. Connect the cable to the 3-pole terminal block according to the operating mode. Ensure that the conductors are plugged completely into the terminal points up to their insulation.

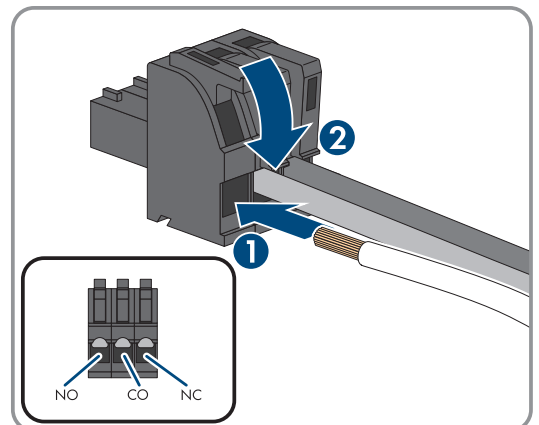

6. Insert the three-pole terminal block with the connected conductors into the **MFR** slot.

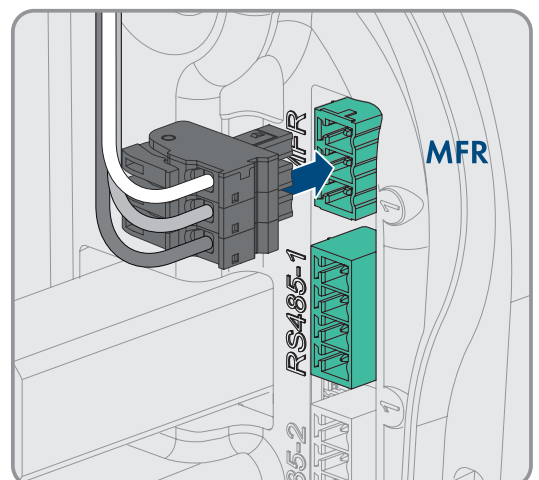

7. Secure the cable to a strut using a cable tie, and cut off the protruding end of the cable tie with a suitable tool.
8. Ensure that the terminal block is securely in place.
9. Ensure that all conductors are correctly connected.
10. Ensure that the conductors sit securely in the terminal points. Tip: To release the conductors, open the terminal points using a suitable tool.

7.8.4 Controlling the loads via multifunction relay

The multifunction relay can control loads (such as sockets in the charging station column). To do this, a contactor (K1) must be connected to the multifunction relay. The contactor (K1) switches the operating current for the load on and off.

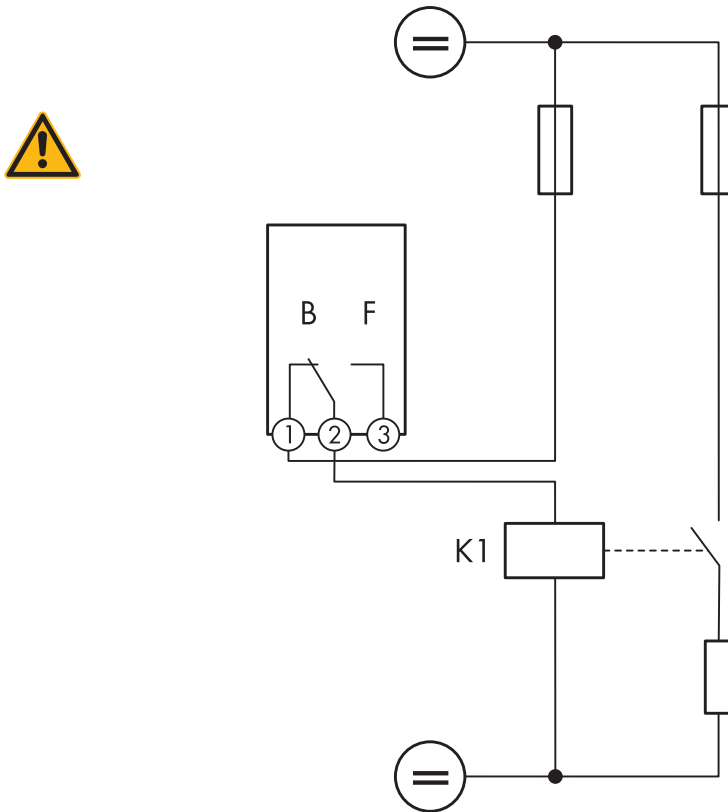

Figure 24: Wiring diagram for connection to control a load

7.9 Connecting to the RS485 interface

7.9.1 RS485 input

The charging station can communicate with wired SMA communication products or approved meters via the RS485 interface. The function is determined by the software functionality.

7.9.2 RS485 pin assignment

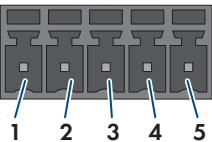
RS485 interface	Pin	Assignment
	1	Data+
	2	Not assigned
	3	GND
	4	Data -
	5	Shield

7.9.3 Connecting RS485

⚠ QUALIFIED PERSON

Additional required material (not included in the scope of delivery):

- One communication cable for RS485 communication

Requirements:

- The communication cable must be technically suitable for connecting to the RS485 interface (see Section 7.1.8, page 55).
- The same baud rate (1200 baud, 9600 baud or 19200 baud) must be set in all RS485 devices.

Procedure:

1. Disconnect the charging station from voltage sources (see Section 10, page 99).
2. Connect the communication cable to the RS485 interface (see manufacturer's instructions).
3. Run the cable to the **RS 485-1** slot.
4. Dismantle the cable by 80 mm.
5. Strip off the conductor insulation by 6 mm.
6. Unlock the conductor inserts on the provided 5-pole connector.

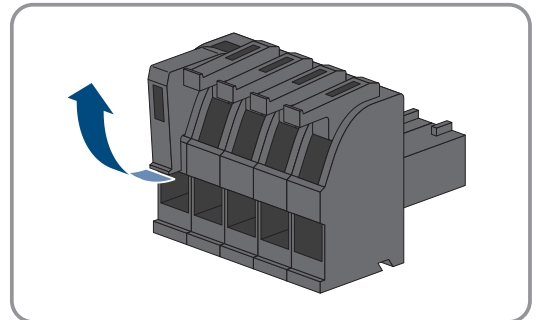

7. Connect the conductors of the connection cable to the supplied five-pole connector. To do so, plug the conductors into the conductor entries and close the conductor entries. Observe the connector assignment.

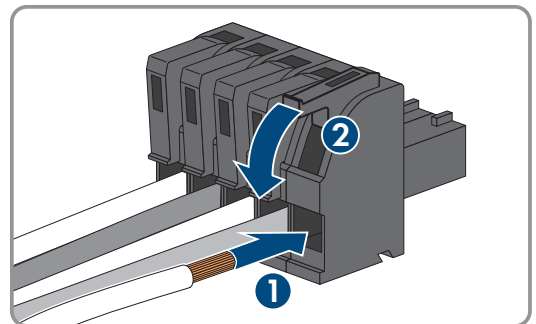

8. Plug the five-pole connector into the port **RS 485-1** on the product. Observe the pin assignment.

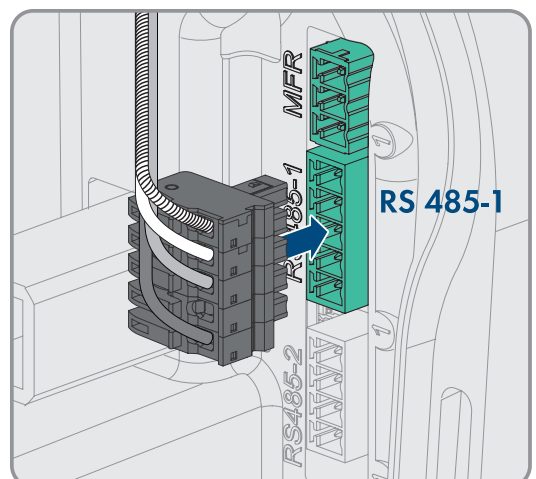

9. Secure the cable to a strut using a cable tie, and cut off the protruding end of the cable tie with a suitable tool.
10. Ensure that the connector is securely in place.
11. Ensure that all conductors are correctly connected.
12. Ensure that the conductors sit securely in the terminal points.

7.10 Close the enclosure cover.

⚠ QUALIFIED PERSON

Procedure:

1. Close unused enclosure opening with filler plugs.
2. First, insert the cover at the bottom of the enclosure at an angle of about 70° and then carefully push it forward.

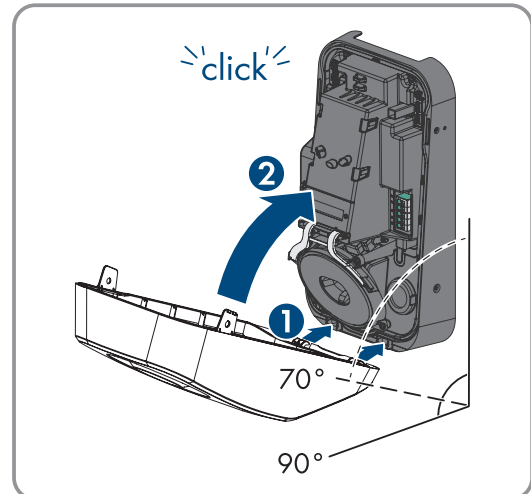

The cover audibly snaps into place.

3. Fasten the two screws (M5 x 8) from the scope of delivery on the right and left sides (TX25, tightening torque: 2.2±0.2 Nm).

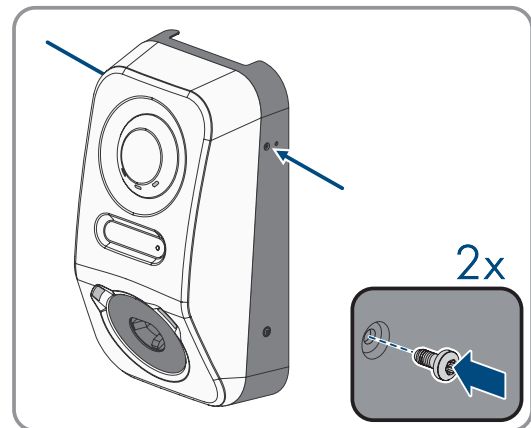

8 Commissioning

8.1 Procedure for commissioning in combination with Sunny Home Manager 2.0

⚠ QUALIFIED PERSON

This section describes the procedure of commissioning a charging station that is used in systems with Sunny Home Manager. For commissioning, proceed as described in this section and perform the steps in the given order.

i Select no country data set

No country data set may be selected in the commissioning wizard.

- Skip this step in the commissioning wizard.

Procedure	See
1. Commission the charging station.	Section 8.5, page 75
2. Establish a connection to the user interface of the charging station. There are various connection options to choose from for this: <ul style="list-style-type: none"> • Direct connection via Wi-Fi • Connection via Wi-Fi in the local network • Connection via Ethernet in the local network 	Section 9.2.3, page 82 Section 9.2.2, page 80
3. If required, change the network configuration on the welcome page. The automatic network configuration recommended by SMA Solar Technology AG via DHCP server is activated by default. Only change the network configurations if the default configuration is not suitable for your network.	Commissioning Assistant
4. Carry out the configuration using the Commissioning Assistant. Select System Manager in the device configuration.	Commissioning Assistant
5. Register the Sunny Home Manager 2.0 and SMA Energy Meter as SMA Speedwire devices. Information: If the SMA eCharger is operated in combination with the Sunny Home Manager 2.0, then only the Sunny Home Manager 2.0 or SMA Energy Meter must be added via the SMA Speedwire device registration in this step. No SMA inverters may be added. SMA inverters are added to the system via the Sunny Home Manager 2.0 and the Sunny Portal.	Commissioning Assistant
6. Add the charging station as a device to a Sunny Portal system with Sunny Home Manager 2.0.	SUNNY PORTAL powered by en-nexOS - User Manual

See also the following video for additional information:

TechTip: SMA eCharger Inbetriebnahme



TechTip: SMA eCharger start-up



8.2 Procedure for commissioning in secure power supply operation

⚠ QUALIFIED PERSON

This section describes the procedure of commissioning a charging station that is used in stand-alone mode.

Only one device in the system can be used as System Manager at a time (e.g. SMA Data Manager or a charging station as System Manager). All other devices must be configured as a subordinate device and recorded in the System Manager.

It provides an overview of the steps, which must be performed in the prescribed sequence.

i Select no country data set

No country data set may be selected in the commissioning wizard.

- Skip this step in the commissioning wizard.

Procedure	See
1. Commission all SMA Speedwire devices that are to be subordinate to the System Manager (e.g. inverters).	Manual of the devices
2. Commission the charging station that is to be configured as the System Manager.	Section 8.5, page 75
3. Establish a connection to the user interface of the charging station that is to be configured as System Manager. There are various connection options to choose from for this: <ul style="list-style-type: none"> • Direct connection via Wi-Fi • Connection via Wi-Fi in the local network • Connection via Ethernet in the local network 	Section 9.2.3, page 82 Section 9.2.2, page 80
4. If required, change the network configuration on the welcome page. The automatic network configuration recommended by SMA Solar Technology AG via DHCP server is activated by default. Only change the network configurations if the default configuration is not suitable for your network.	Commissioning Assistant
5. Carry out the configuration using the Commissioning Assistant. Select Charging station as System Manager in the device configuration.	Commissioning Assistant
6. Make further settings if necessary (e.g., configure multifunction relay).	Section 9, page 79
7. To monitor the system in the Sunny Portal and view the data visually, create a user account in the Sunny Portal and create a system in the Sunny Portal powered by ennexOS or add devices to an existing system.	https://ennexOS.SunnyPortal.com

8.3 Procedure for connecting to the SMA Data Manager M

⚠ QUALIFIED PERSON

This section describes the procedure for connecting the charging station to the SMA Data Manager M.

Requirements:

- The SMA eCharger has the firmware version $\geq 2.5.9.R$
- The SMA Data Manager (EDMM-10 / EDMM-20) has the firmware version $\geq 2.5.9.R$

It provides an overview of the steps, which must be performed in the prescribed sequence.

Procedure	See
1. Commission the charging station.	Section 8.5, page 75
2. Establish a connection to the user interface of the charging station. There are various connection options to choose from for this: <ul style="list-style-type: none"> • Direct connection via Wi-Fi • Connection via Wi-Fi in the local network • Connection via Ethernet in the local network 	Section 9.2.3, page 82 Section 9.2.2, page 80
3. If required, change the network configuration on the welcome page. The automatic network configuration recommended by SMA Solar Technology AG via DHCP server is activated by default. Only change the network configurations if the default configuration is not suitable for your network.	Commissioning Assistant
4. Carry out the configuration using the Commissioning Assistant. Select Charging station as System Manager in the device configuration.	Commissioning Assistant
5. Connect to the user interface of the charging station and enter the value [502] for the parameter Modbus TCP server port under Configuration > Parameters .	Section 9.6, page 87
6. Make further settings if necessary (e.g., configure multifunction relay).	Section 9, page 79
7. Commission the SMA Data Manager (EDMM-10 / EDMM-20).	See the product manual
8. Establish a connection to the user interface of the SMA Data Manager. <ul style="list-style-type: none"> • Select the menu item Device administration in the Configuration menu. • Select the + button. • Select Modbus devices and confirm with [Next]. • Select Manage Modbus profiles. • Select Create a new Modbus profile. • Fill out the entry fields and select [Save]. • Search for available Modbus devices in the system. • Select the Modbus device to be added to the system and select [Save]. • Check whether the measured values are being read correctly. 	See the product manual
9. To monitor the system in the Sunny Portal and view the data visually, create a user account in the Sunny Portal and create a system in the Sunny Portal or add devices to an existing system.	https://ennexOS.SunnyPortal.com

Also see:

- [SMA Modbus Client Profile ⇒ page 86](#)
- [Registering a New Modbus Device and Assigning a Modbus Profile ⇒ page 86](#)
- [Creating a New Modbus Client Profile ⇒ page 86](#)

8.4 Procedure for device configuration

QUALIFIED PERSON

This section describes the procedure of device configuration for a charging station.

It provides an overview of the steps, which must be performed in the prescribed sequence.

Settings at point of interconnection	Explanation	See
1. Grid nominal voltage	Nominal value of the grid (e.g., 230 V)	Section 9.5.3, page 85
2. Maximum unbalanced load	Unbalanced load limit per national regulations (e.g., 4.6 kW in Germany). This is important for regulating the operation of single-phase and two-phase charging vehicles and the boost function. Information: If no unbalanced load limit is required, the set value remains at 7400 W.	Section 9.5.3, page 85
3. Phase assignment	Assign line conductors in the same way as the Sunny Home Manager 2.0 or Energy Meter at the point of interconnection. Important for the integrated unbalanced load regulation function. Information: If the charging station is to be operated in single-phase mode, select the line conductor in this step.	Section 9.5.3, page 85
Operation with meter at point of interconnection	Explanation	See
1. Nominal current of the point of interconnection	Nominal value of the selective circuit protection at the point of interconnection or at the Sunny Home Manager. Important for control to ensure power outage protection.	Section 9.5.3, page 85
2. Active power limitation fallback value, control at the point of interconnection	Fallback charging power in case of loss of communication.	Section 9.5.3, page 85
Charging settings	Explanation	See
1. Nominal active power	Ability to limit the maximum charging power, e.g., to 11 kW.	Section 9.5.3, page 85
2. Minimum charging current	According to IEC 61851, min. 6 A. Can be adjusted for the specific vehicle, e.g., to 10 A.	Section 9.5.3, page 85
3. AC current limitation	Nominal value of the miniature circuit breaker for the separate electric circuit for the charging station.	Section 9.5.3, page 85
4. Disconnection after full charge	Relevant for the Sunny Home Manager to plan and reserve charging power. Select Yes if the available power is to be provided to the other optional loads after the charging process is completed. Select No if the charging station is the only controlled load, or if prior climate control is to be used.	Section 9.5.3, page 85

Charging settings	Explanation	See
5. Standby for charging process to disconnection	Time until activation of "Disconnect after full charge." The default value is set to 15 minutes.	Section 9.5.3, page 85
6. Lock the charging cable to the charging station	Permanent locking of the charging cable to the charging station.	Section 9.5.3, page 85

Settings in the delta IT system	Explanation	See
1. PE ground connection	<p>For firmware versions >2.5.xx.R, the parameter Ground connection monitoring is enabled by default. In a delta IT system, grounding monitoring cannot be carried out due to the physical characteristics of this system configuration.</p> <p>After startup, the SMA eCharger indicates event E-901: "PE connection missing." Operation will not continue. Firmware version 2.5.29.R provides the option to disable ground connection monitoring.</p> <p>For the parameter Ground connection monitoring, select the value No. Then restart the SMA eCharger.</p>	Section 9.5.3, page 85

8.5 Commissioning the Product

QUALIFIED PERSON

NOTICE

Damage to the vehicle during emergency or battery-backup operation

During emergency or battery-backup operation, three-phase loads may be connected to a single-phase utility grid with phase coupling. This can damage the vehicle.

- Emergency and battery-backup operation must be clarified with and approved by the vehicle manufacturer in advance.
- Ensure that, during phase coupling, only single-phase loads are connected to the battery-backup grid.

i Observe the following information about the charging cable

- Always pull the charging cable out of the port by the connector, never by the cable itself.
- The charging cable must not be mechanically damaged (kinked, pinched, or run over) and the contact area must not make contact with heat sources, dirt, or water.
- Never use defective, worn, or dirty charging plugs.
- Do not use extension cord sets.
- Do not use adapters of any kind.
- Follow the information and manuals for your vehicle before using the charging station to charge the vehicle.
- Use the protective cap when the charging cable is not in use.
- Do not put the charging cable under tension. Do not touch the pin contacts.
- Avoid knots in the charging cable.
- Unwind the charging cable all the way when charging.
- The charging cable is a trip hazard when lying on the ground. Store the charging cable properly or use the cable hanger when the charging process is completed.
- The charging cable is a wearing part and must be visually inspected regularly (before each charging process).

Requirements:

- The AC circuit breaker must be correctly rated and mounted.

Information: the charging station does not have a dedicated disconnect switch. The miniature circuit breaker in the supply line serves as a disconnect device.

- The product must be correctly mounted.
- All cables must be correctly connected.
- The enclosure lid must be mounted.

Procedure:

1. If necessary, switch on the supply of the connected signal sources.
2. Switch on the AC miniature circuit breaker.

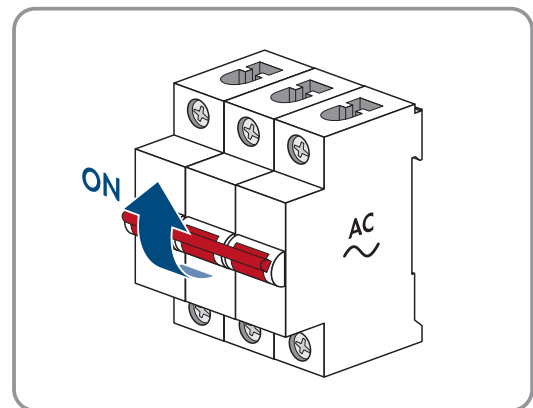

3. Wait until the product is ready for operation. **Information:** The procedure takes approx. 5 minutes.

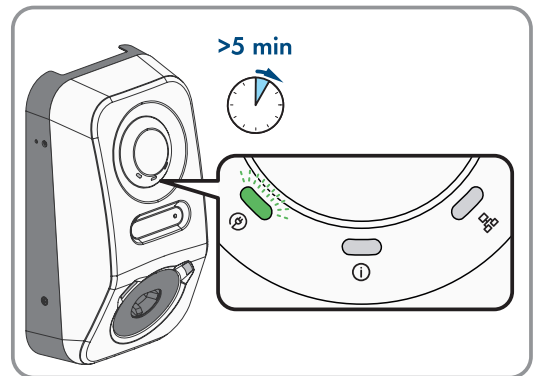

☑ The LED is glowing green.

4. Insert a type 2 charging cable into the terminal provided on the product. The mechanical protection against contact results in a two-step process for inserting into the charging port. The charging cable must overcome two resistance points when inserted so that it is in the correct position. The integrated locking mechanism ensures that the charging cable cannot be pulled out during the charging process and that current flows only when the vehicle is correctly connected to the charging station.

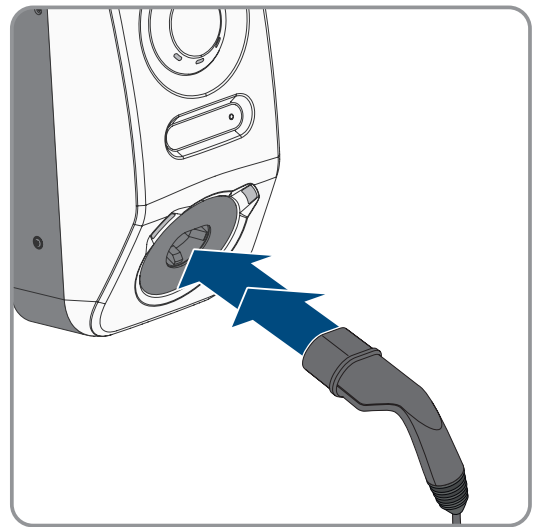

5. Test the charging station in accordance with IEC 61851 and complete the test report. An example of a test report can be found at [Test report](#).

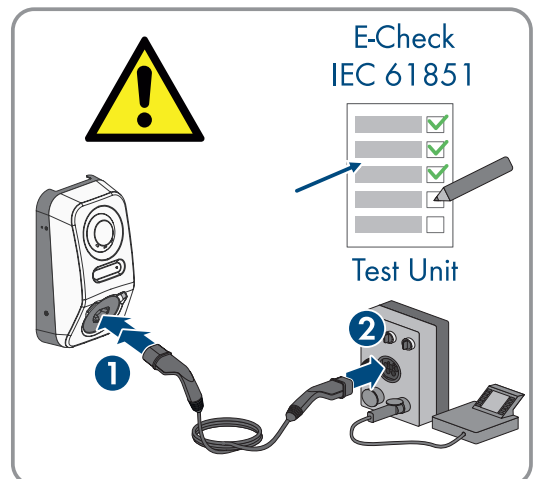

6. If the green and red LEDs flash simultaneously during commissioning, operation is stopped because the commissioning procedure has not been (fully) carried out. For the charging station to begin operation, the configuration must be completed.
7. If the green LED is still flashing, the conditions for activating charging operation are not yet met. As soon as the conditions for charging mode are met, the charging station starts charging and the green LED lights up continuously, depending on the available power level.
8. If the red LED lights up, an event has occurred. Find out which event has occurred and, if necessary, initiate countermeasures.
9. Ensure that the charging station is charging properly.

10. Status "Initialize"

If the charging station is in "Initialize" status after commissioning, the meter configuration has not been carried out or has been carried out incompletely. Check whether the Sunny Home Manager 2.0 or SMA Energy Meter has been added to the SMA Speedwire device registration. To do this, log in to the user interface and check the settings under **Configuration > Device Management**. Then check whether the meter configuration for grid-supplied power and feed-in meters has been carried out under **Configuration > Meter Configuration**.

See also the following video for additional information:

TechTip: Connecting the charging cable to the SMA eCharger



TechTip: Connect the charging cable to the SMA eCharger



8.6 Transfer to the operator

When installation and commissioning are complete, give all documentation to the operator. The operator must be instructed on the following points:

- Safety when using the charging station
- Appropriate procedures for inspecting and maintaining the charging station
- Meaning of the LED indicators
- Position and function of the AC miniature circuit breaker to switch off or restart the charging station
- Contact partner in case of problems
- Access to the Sunny Portal (powered by ennexOS)
- SMA Energy App
- Information on product registration

9 Operation

9.1 Design of the User Interface

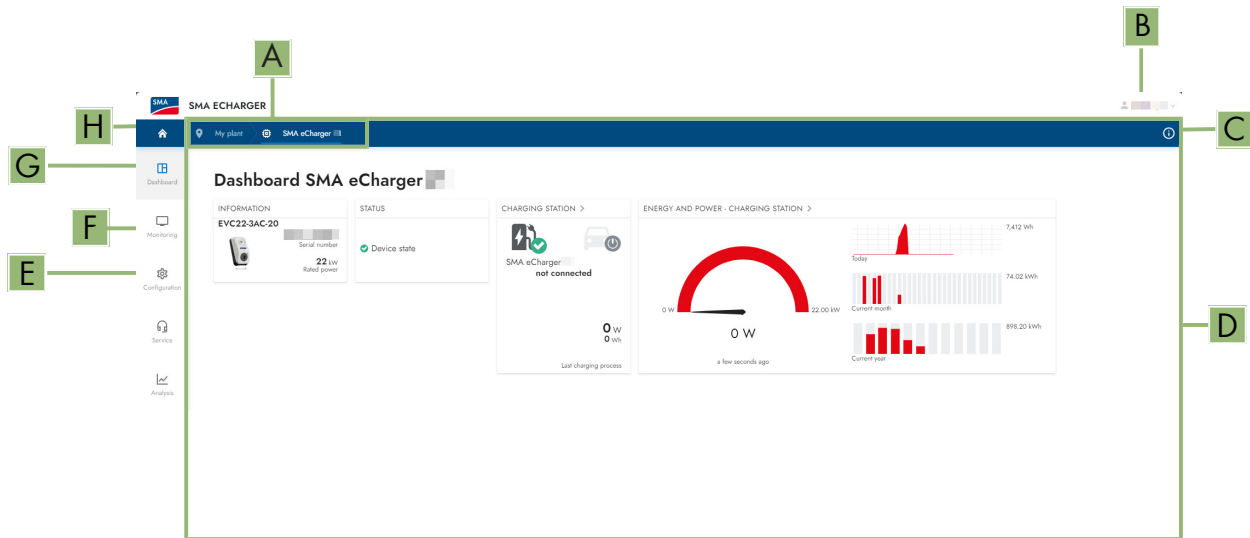

Figure 25: Design of the User Interface

Position	Designation	Description
A	Focus navigation	Enables the navigation between the following levels: <ul style="list-style-type: none"> • System • Device
B	User settings	Provides the following functions: <ul style="list-style-type: none"> • Configuring personal data • Logout
C	System information	Displays the following information: <ul style="list-style-type: none"> • System • Device information • Licenses • eManual
D	Content Area	Displays the dashboard or content of the selected menu.
E	Configuration	Offers different views for configuration, depending on the selected level and user role.
F	Monitoring	Offers different views for monitoring, depending on the scope of the connected devices.
G	Dashboard	Displays information and instantaneous values of the device or system currently selected.
H	Home	Opens the user interface home page

9.2 Establishing a Connection to the User Interface of the Product

9.2.1 Information on establishing a connection

To establish a connection, SMA Solar Technology AG recommends only using Wi-Fi for commissioning. For a stable connection, especially in systems with e.g. system control or energy management, an Ethernet connection is advisable in order to prevent feed-in problems or yield losses.

9.2.2 Connection in the local network

9.2.2.1 Access addresses for the product in the local network

i DHCP Server is recommended

The DHCP server automatically assigns the appropriate network settings to your nodes in the local network. A manual network configuration is therefore not necessary. In a local network, the Internet router is usually the DHCP server. If the IP addresses in the local network are to be assigned dynamically, DHCP must be activated in the Internet router (see the Internet router manual). In order to receive the same IP address by the internet router after a restart, set the MAC address binding.

In networks where no DHCP server is active, proper IP addresses must be assigned from the free address pool of the network segment to all network participants to be integrated during commissioning.

i Communication disturbances in the local network

The IP address range 192.168.12.0 to 192.168.12.255 is reserved for internal communication and direct access between SMA products and cannot be used for system communication within the local network.

Communication problems might occur if this IP address range is used in the local network.

- Do not use the IP address range 192.168.12.0 to 192.168.12.255 in the local network.

If the product is connected to a local network (e.g. via an Internet router or Wi-Fi), the product will receive a new IP address. Depending on the type of configuration, the new IP address will be assigned automatically by the DHCP server (Internet router) or manually by you.

Upon completion of the configuration, the product can only be reached via the listed access addresses in the local network:

- Generally applicable access address: IP address manually assigned or assigned by the DHCP server (Internet router) (identification via network scanner software or network configuration of the Internet router).
- Access address: **https://SMA[serial number]** (e.g. **https://SMA0123456789**)

9.2.2.2 Ports for data communication in the local network

In small local networks the use of certain ports is unrestricted. In industrial networks, the use of these ports may require authorization from the system administrator. For proper operation, the outgoing Internet connection must allow the use of the following ports and URLs:

Port and URL	Use
Port 80 and 443 (http/https) update.sunnyportal.de	Updates
Port 123 (NTP) ntp.sunnyportal.com	Time synchronization with Sunny Portal (if not provided by the Internet router)
Port 443 (https/TLS) ldm-devapi.sunnyportal.com	Data transmission

Port and URL	Use
Port 443 (https/TLS) ennexos.sunnyportal.com	User interface
Port 9524 (TCP) wco.sunnyportal.com	SMA Webconnect 1.5 and SMA SPOT

9.2.2.3 Establishing a Connection via Ethernet in the local network

Requirements:

- The product must be connected to the local network via a network cable (e.g. via a router).
- The product must be integrated into the local network. Tip: You can change the network configuration on the welcome page of the product.
- A smart device (e.g. laptop) must be available.
- The smart device must be in the same local network as the product.
- The respective latest version of one of the following web browsers must be installed on the smart device: Chrome, Edge, Firefox or Safari.

Procedure:

1. Open the web browser of your smart device.
 2. Enter the access address of the product in the address bar of the web browser.
- When you connect to the user interface for the first time, the welcome page opens. The Commissioning Assistant for configuring the product can be started via the welcome page.
 - The login page of the user interface opens if the product has already been configured.

Also see:

- [SMA Speedwire](#) ⇒ page 29
- [Access addresses for the product in the local network](#) ⇒ page 80
- [Ports for data communication in the local network](#) ⇒ page 80

9.2.2.4 Establishing a Connection via WLAN in the Local Network

Requirements:

- The product must be commissioned.
- The product must be integrated into the local network. Tip: You can change the network configuration on the welcome page of the product.
- A smart terminal device (e.g., laptop) must be available.
- The smart terminal device must be in the same local network as the product.
- The respective latest version of one of the following web browsers must be installed on the smart terminal device: Chrome, Edge, Firefox or Safari.

Procedure:

1. Open the web browser of your smart terminal device.
 2. Enter the access address of the product in the address bar of the web browser.
- When you connect to the user interface for the first time, the welcome page opens. The Commissioning Assistant for configuring the product can be started via the welcome page.
 - The login page of the user interface opens if the product has already been configured.

Also see:

- [Access addresses for the product in the local network](#) ⇒ page 80
- [Ports for data communication in the local network](#) ⇒ page 80

9.2.3 Direct connection via Wi-Fi

9.2.3.1 Connection options for Wi-Fi direct connection

You have several options to connect the product to a smart device. The procedure can be different depending on the devices. If the procedures described do not apply to your end device, establish the direct connection via Wi-Fi as described in the manual of your end device.

The following connection options are available:

- Direct Wi-Fi connection with 360° app Establishing a direct Wi-Fi connection with the 360° app
- Direct Wi-Fi connection with WPS Establishing a direct Wi-Fi connection with WPS
- Direct Wi-Fi connection with Wi-Fi network search (see Section 9.2.3.4, page 82)

9.2.3.2 Access information for direct Wi-Fi connection

Access information for the direct WiFi connection can be found below:

- SSID: **SMA[serial number]** (e.g., SMA0123456789)
- Device-specific Wi-Fi password: WPA2-PSK (see type label of the product)
- Default access address: **https://smalogin.net** or **https://192.168.12.3**

9.2.3.3 Establishing a direct Wi-Fi connection with WPS

Requirements:

- A smart device with WPS function must be available.

Procedure:

1. Activate the WPS Function on the charging station. To do so, tap on the enclosure lid of the product twice.
 - The blue LED flashes quickly for about two minutes. The WPS function is active during this time.
2. Enable the WPS function on your smart device.
3. Open the web browser of your smart device and enter www.smalogin.net in the address bar.
 - When you connect to the user interface for the first time, the welcome page opens. The Commissioning Assistant for configuring the product can be started via the welcome page.
 - The login page of the user interface opens if the product has already been configured.

Also see:

- [Access information for direct Wi-Fi connection](#) ⇒ page 82

9.2.3.4 Establishing direct Wi-Fi connection with Wi-Fi network search

1. Search for Wi-Fi networks with your smart device.
2. Select the SSID of the product **SMA[serial number]** in the list with the detected Wi-Fi networks.
3. Enter the device-specific Wi-Fi password (see WPA2-PSK on the type label).

4. Open the web browser of your smart end device and enter **https://smalogin.net** in the address bar.
 - When you connect to the user interface for the first time, the welcome page opens. The Commissioning Assistant for configuring the product can be started via the welcome page.
 - The login page of the user interface opens if the product has already been configured.
5. If the login page of the user interface does not open, enter the IP address **https://192.168.12.3** or, if your smart terminal supports mDNS services, **SMA[serial number].local** or **https://SMA[serial number]** in the address bar of the web browser.

Also see:

- [Access information for direct Wi-Fi connection](#) ⇒ page 82

9.2.4 WPS function

9.2.4.1 Connection options with WPS

You have several options to use the WPS function. Depending on the possible application of the WPS function, the procedure for activation will vary.

The following options are available:

- WPS for automatic connection to a network (e.g. via a router)
- WPS for direct connection between the product and a smart device

9.2.4.2 Activating WPS for automatic connection

Requirements:

- WLAN must be activated in the product.
- WPS must be activated on the router.
- The user interface is open and you are logged in.

Procedure:

1. Select the menu **Configuration**.
 2. Select **Network configuration** menu item.
 3. Click on the button **Use WPS** in the **Wi-Fi** section.
 4. Click on [**Save**].
- The WPS function is activated and the automatic connection to the network can be established.

9.2.4.3 Activating WPS for direct connection to a smart device

- Tap on the enclosure lid of the product twice in direct succession.
- The WPS function is activated for about 2 minutes. Activation is indicated by a slow flashing blue LED.

9.3 Configuring Service Access

The PUK 2.0 function allows you to grant an SMA-authorized service user access to the product's user interface in the event of a product malfunction or when performing warranty services. With PUK 2.0, you can configure yourself whether and for how long service access to your system is possible. If no service access is configured, your system cannot be accessed.

In order for the service user to access your system, a VPN connection may also need to be set up.

Requirements:

- The product's user interface must be open and you must be logged in.

Procedure:

1. In the user settings, select **PUK 2.0 configuration**.
2. Select [**Configure**].
3. Select the desired duration for service access.
4. Click on [**Save**].

9.4 User Management

9.4.1 Access rights to the user interface

During registration, 1 user with administrator rights is created. With administrator rights, you can add further system users who can configure user rights or delete users.

This gives users access to the system and to the devices recorded in the system.

You can assign the following roles for users:

- User
- Installer

In addition, administrator rights can be assigned for each role.

9.4.2 Add new user

QUALIFIED PERSON

Requirements:

- You are logged in as **Administrator** on the device's user interface.

Procedure:

1. Go to **User administration** via **Configuration**.
2. Open the settings options by clicking on  in the table.
3. Fill out the form.
4. Confirm with [**Save**].

9.4.3 Changing User Rights or User Information

QUALIFIED PERSON

Requirements:

- You are logged in as **Administrator** on the device's user interface.

Procedure:

1. Go to **User administration** via **Configuration**.
2. Open the settings options via  in the row for the user whose rights need to be changed.
3. Make the required changes.
4. Confirm with [**Save**].

9.4.4 Delete user accounts

QUALIFIED PERSON

If the password is lost, all user accounts can be reset and recreated. All system data will be retained.

Individual user accounts can be deleted via **Configuration > User management** if a user with administrator rights is still able to log in.

Requirements:

- The Device Key on the password sheet enclosed in the documentation package must be included in the scope of delivery.
- The login page of the user interface must be open.

Procedure:

1. Click [**Delete user accounts?**] button.
 2. Enter Device Key.
 3. Select [**Delete**].
- The product is performing a restart. Then a new user account can be created.

9.5 Device Administration

9.5.1 Register Devices

You can register new devices and add them to the system on system level. This is required, for example, if your system has been expanded.

Requirements:

- The user interface must be open and you must be logged in.

Procedure:

1. Select the system in the focus navigation.
2. Select the menu **Configuration**.
3. Select the **Device management** menu item.
4. Select the **+** button.
5. Follow the steps of the device registration wizard.

9.5.2 Delete devices

You can delete registered devices on system level.

Requirements:

- The user interface must be open and you must be logged in.

Procedure:

1. Select the system in the focus navigation.
2. Select the menu **Configuration**.
3. Select the **Device management** menu item.
4. In the row of the device to be deleted, click the **...** button.
5. Select **Delete device**.
6. Select [**Delete**] in the displayed message.

9.5.3 Configure device

You can adjust the settings at the point of interconnection and the charging settings.

Procedure:

1. Select the product in the focus navigation.
2. Select the menu **Configuration**.
3. Select the menu item **Device configuration**.

4. Change the settings.
5. Click on [**Save**].

9.5.4 Modbus

9.5.4.1 SMA Modbus Client Profile

Connected Modbus devices can be used, for example, as energy meters for generation and consumption data at the point of interconnection or for energy monitoring. For this, predefined Modbus profiles, user-created Modbus profiles or the SunSpec Modbus profile must be used. The Modbus profiles will then be assigned to the Modbus devices.

i IP addresses of Modbus devices

In systems with Modbus devices, static IP addresses must be assigned to all Modbus devices. Suitable IP addresses can be assigned to the Modbus devices from the free address supply of the network segment either manually or dynamically via DHCP.

If the IP addresses are to be assigned dynamically, DHCP must be activated in the Internet router (see the Internet router manual). Make sure that the Modbus devices do not contain variable IP addresses but always the same IP addresses (static DHCP).

This also applies to Data Managers that are used as subordinate devices.

If IP addresses of Modbus devices have been changed, all devices must be restarted.

9.5.4.2 Creating a New Modbus Client Profile

Requirements:

- The user interface must be open and you must be logged in as **Installer**.

Procedure:

1. Select the system in the focus navigation.
2. Select the menu item **Device administration** in the **Configuration** menu.
3. Select the **+** button.
4. Select **Modbus devices** and confirm with [**Next**].
5. Select **Manage Modbus profiles**.
6. Select **Create a new Modbus profile**.
7. Fill out the entry fields and select [**Save**]. The device type and the mapping template, for example, specify the required Modbus registers.

9.5.4.3 Registering a New Modbus Device and Assigning a Modbus Profile

Requirements:

- The user interface must be open and you must be logged in as **Installer**.
- The connected Modbus devices must be configured to update their setpoints in cyclic intervals (maximum cycle time: 1 minute; recommended cycle time: 1 second).
- The Modbus devices must be in operation and connected to the product.

Procedure:

1. Select the system in the focus navigation.
2. Select the menu item **Device administration** in the **Configuration** menu.
3. Select the **+** button.
4. Select **Modbus devices** and confirm with [**Next**].

5. Fill out the input fields and confirm with **[Next]**.
 - Available Modbus devices in the system are searched for and displayed.
6. Select the Modbus devices to be added to the system and select **[Save]**.
 - The connected Modbus device can be used as an energy meter for generation and consumption data at the point of interconnection or for energy monitoring or as sensor for wind speed, solar irradiation, and temperature.

9.6 Changing parameters

The parameters of the product are set to certain values by default. You can change the parameters to optimize the performance of the product.

This section describes the basic procedure for changing parameters. Always change parameters as described in this section.

Requirements:

- The product's user interface must be open and you must be logged in.
- Changes to grid-relevant parameters must be approved by the responsible grid operator, and can only be made as an **installer**.

Procedure:

1. Choose the product in the focus navigation.
2. Select the menu **Configuration**.
3. Select the menu item **Parameters**.
4. Call up the parameter via the search function or navigate to the parameter.
5. Change the parameter value.
6. Click on **[Save]**.

9.7 I/O configuration

9.7.1 Digital output (MFR)

9.7.1.1 Use of the digital output (MFR)

The digital output (MFR) can be switched depending on measured values or states.

You have several options to use the digital output.

Possible use	Category	Explanation
Notification in the event of an error	System state	System is in warning or error state.
Alarm in case of warning or error	System state	System is in error state.
Setpoint of active power limitation ¹⁾	Setpoints	The active power value currently to be set
System active power (grid-supplied power) ¹⁾	Grid connection point	Currently drawn active power.

9.7.1.2 Configure the digital output (MFR)

QUALIFIED PERSON

Requirements:

- A signal source must be connected to the digital output (**MFR**).
- The charging station to which the signal source is connected must be configured as System Manager.

¹⁾ Conditions for activating the outlet signal must be specified

- The user interface must be open and you must be logged in as **Installer** or **Administrator**.

Procedure:

1. Select the product in the focus navigation.
2. Select the menu **Configuration**.
3. Select the menu item **I/O configurations**.
4. Select the type of the I/O channel **Digital output**.
5. Select the use for the digital output.
6. If necessary, activate inversion of the signal. Observe the pin assignment of the terminal block.
7. Click on [**Save**].

9.7.2 Configuring the fast stop function**⚠ QUALIFIED PERSON****Requirements:**

- The user interface must be open and you must be logged in.

Procedure:

1. Select the product in the focus navigation.
2. Select the menu **Configuration**.
3. Select the menu item **I/O configurations**.
4. Select the type of the I/O channel **Digital input**.
5. Select the use for the digital input **Signal fast stop**.
6. Select the source of the digital value.
7. Select the digital input that is to be used as the fast stop.
8. If necessary, activate inversion of the signal.
9. Assign a name to the I/O channel.
10. Click on [**Save**].

9.8 Update and backup**9.8.1 Automatically Updating the Firmware**

By activating the automatic firmware update, the product searches and installs new firmware versions automatically provided an Internet connection exists. In the process, an available firmware update may take up to 48 hours.

i Functional limitations during the update

While an update is being performed, the functions of the product may be limited. The product is performing a restart and may be without function at times. This process takes several minutes and cannot be canceled.

The automatic firmware update can be activated via the user interface during commissioning.

Requirements:

- The user interface must be open and you must be logged in as **User**.

Procedure:

1. Select the product in the focus navigation.
2. Select the menu **Configuration**.
3. Select the menu item **Parameters**.

4. Select the value **Yes** for the parameter **Automatic updates activated**.
5. Click on **[Save]**.

9.8.2 Performing a Manual Firmware Update via the User Interface

QUALIFIED PERSON

Functional limitations during the update

While an update is being performed, the functions of the product may be limited. The product is performing a restart and may be without function at times. This process takes several minutes and cannot be canceled.

Charging process is interrupted

If a manual firmware update is performed during an active charging process, the charging process will be interrupted. The charging process must then be restarted. SMA Solar Technology AG recommends performing a manual firmware update without a connected vehicle.

Charging cable lock disabled after firmware update of the device

It may happen that the charging cable lock (parameter: **Lock the charging cable to the charging station**) is deactivated after a firmware update of the device.

- The charging cable lock is automatically activated the next time a vehicle is charged.

Requirements:

- An update file with the desired firmware of the product must be available. You can download the update file, for example, from the product page under www.SMA-Solar.com.
- The user interface must be open and you must be logged in as **User**.

Procedure:

1. Select the product in the focus navigation.
2. Select the menu **Configuration**.
3. Select the **Update and backup** menu item.
4. In the **Manual update** area, click **[Select file]** and select the update file for the product.
 - The user interface confirms that the update file is compatible.
5. If the user interface does not confirm the compatibility of the update file, replace the update file.
6. Select **[Start update]**.
7. Follow the instructions in the dialog.
 - The product is performing a restart after the firmware update.
8. Select the **Monitoring** menu.
9. Select the menu item **Event monitor**.
10. Check in Events, Parameter Settings, or Device Properties whether the firmware update has been completed successfully.

9.8.3 Function and content of the backup file

The backup file is used to transfer configuration information, e.g., when commissioning a replacement device or when restoring previously saved parameter settings.

The backup file includes the following system and device configuration data for your product:

- Grid Management Services
- Ethernet
- Energy meter

- Sunny Portal setting
- Self-defined Modbus profiles
- System password
- User interface login data
- List of connected devices
- Added RFID cards

The following information is not included in the backup file:

- Notifications
- Wi-Fi data
- Historic energy and performance values
- Event messages

9.8.4 Creating a Backup File

Requirements:

- The user interface must be open and you must be logged in.

Procedure:

1. Select the product in the focus navigation.
2. Select the menu **Configuration**.
3. Select the **Update and backup** menu item.
4. Select the [**Create backup file**] button.
5. Enter a password to encrypt the backup file and confirm with [**Create and download backup file**]. Please note that the password will be needed later for importing the backup file.
 - An Ibd file with all parameter settings will be downloaded.

Also see:

- [Function and content of the backup file ⇒ page 89](#)

9.9 Resetting the product to default setting

i Loss of data due to replacement or due to resetting to default settings

If the product is reset to default settings, it must then be added again to the Sunny Home Manager 2.0 system under **Configuration > Device Management**, as it will be assigned a new identification number. If this step is not performed, the product cannot be controlled by the Sunny Home Manager.

Requirements:

- The user interface must be open and you must be logged in.

Procedure:

1. Select the product in the focus navigation.
2. Select the menu **Configuration**.
3. Select the menu item **Device properties**.
4. Select the button [**If you want to reset the device to the default settings, click here**].
5. Select [**Reset**].

9.10 Activating the Charging Release

This function can protect the charging station from unauthorized use. After activation, the charging station is locked and each charging process must be released via the SMA Energy App, an RFID card, or the user interface. When charging is complete, the charging station is locked again.

Procedure:

1. Log into the user interface.
2. Select the menu item **Access management** in the menu **Configuration**.
3. Select [**Allow charging**].

i Information on NFC

NFC (near field communication) is a technology for contactless data exchange in the near field range and is based on high-frequency RFID technology. Many smartphones support NFC and are therefore able to simulate contactless cards for authentication purposes. Under certain conditions, a smartphone (or smartwatch) can also be used for authentication on the SMA eCharger. It is important that the end device uses a static (rather than dynamic) UID.

SMA Solar Technology AG recommends using an RFID card or RFID token with a static UID.

9.11 Teaching RFID cards

Requirement:

- Charging approval is activated
- The user interface must be open and you must be logged in.

Procedure:

1. Select the menu item **Access management** in the menu **Configuration**.
2. Select [**Add card**].
 - This opens the **Add card** window.

Add card via UID

1. Select [**Enter UID**].
2. Enter the UID and then select [**Accept**].

Information: You can either find the UID (unique and internal card number) on the top left of the card sheet for the two included RFID cards, or it can be read out using the RFID app on a smartphone. Do not use the serial number printed on the RFID card.



- The card has been recognized.
3. You can optionally assign a card name for the previously recognized RFID card.
 4. Click on [**Save**].
 - The RFID has been added to the list of registered RFID cards.

Scanning and adding a card

1. Select [**Scan card**] and start the registration procedure by clicking [**Start registration**]. You now have two minutes to hold the RFID card to be scanned up to the RFID sensor on the control panel of the device (see Section 5.3, page 26).
 - The card has been recognized.
2. You can optionally assign a card name for the previously recognized RFID card.
3. Click on [**Save**].
 - The RFID has been added to the list of registered RFID cards.

9.12 Set ambient lighting

Procedure:

1. Choose the product in the focus navigation.
2. Select the menu **Configuration**.
3. Select the menu item **Parameters**.
4. Find the parameter via **Enable ambient lighting** search and select [**On**].
5. Find the parameter **Ambient lighting brightness** via search and adjust the brightness of the ambient lighting.
6. Click on [**Save**].

Information on ambient lighting:

State	Function of ambient lighting
The charging cable is connected to the charging station and vehicle.	maximum brightness of ambient lighting for 5 minutes
By simply tapping on the knock sensor	maximum brightness of ambient lighting for 5 minutes
The charging cable is removed from the vehicle.	Ambient lighting turns off
Waiting	Ambient lighting changes to the set value after 5 minutes

9.13 Starting and Ending the Charging Process

9.13.1 Properties of Charging Modes

The SMA eCharger has three charging modes that can be switched between. By default, the SMA eCharger is in "**Charging with surplus PV energy**" mode.

The effect of the setting on the charging mode is described below.

Mode	Explanation
Fast charging	The vehicle is charged with the maximum available power. There is no optimization here with regard to electricity costs and the use of PV energy. The charging power is limited by the maximum charging power of the vehicle, the house connection and the charging station.

Mode	Explanation
Charging with surplus PV energy	The vehicle is charged with excess PV energy that would otherwise be fed into the utility grid or cut off. The Sunny Portal is used to set how high the proportion of excess PV energy must be, in order for the charging station to charge the vehicle. The Sunny Home Manager does not schedule the charging station to begin charging until it can fulfill the set optimization target. Depending on the configuration of the priority of the optional load, the charging station is taken into account by the Sunny Home Manager before or after other loads when scheduling. In this charging mode, it is not possible to ensure that the vehicle is charged in all cases. If the surplus PV energy is not sufficient for charging, no charging takes place.
Charging with specified target	The charging station is operated as a necessary load with as much surplus PV energy as possible. By entering a departure time and an amount of energy to be charged in the SMA Energy App, the Sunny Home Manager intelligently plans the charging process. The Sunny Home Manager enables charging at minimum cost and with maximum utilization of PV power with sufficient charging to reach the destination at the entered departure time. After sufficient charging for the target range, the charging station automatically switches to the charging mode Charging with surplus PV energy .

See also the following video for additional information:

TechTip: How to switch between the charging modes of the SMA eCharger



TechTip: How to switch between the charging modes of the SMA eCharger



Automatic phase switching

Automatic phase-switching by the product enables maximum utilization of self-generated solar power. This poses no danger to the electric vehicle's on-board charger because there is a 120-second changeover pause between single- and three-phase charging -

in other words, active single-phase charging process is stopped and three-phase charging process is activated after a short wait. An integrated hysteresis prevents constant switching between the phases.

SMA phase-switching is like a manual interruption in the charging process and causes no vehicle damage when the equipment is properly installed and configured (relay switchover time).

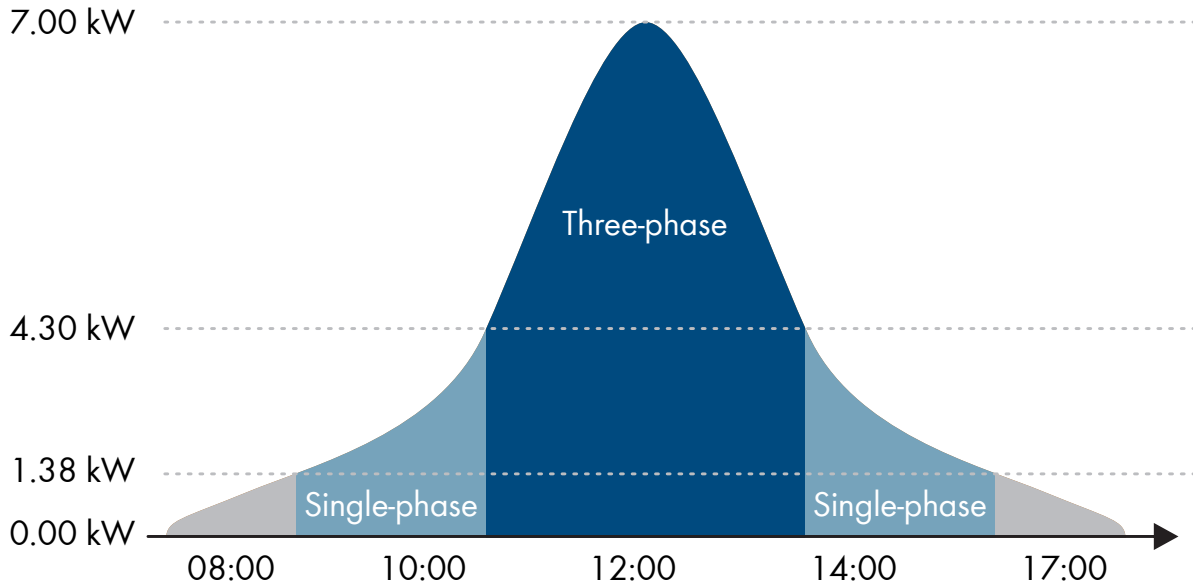

Figure 26: Summer day: Optimal use of strong sunshine through initial single-phase operation, followed by three-phase operation at midday.

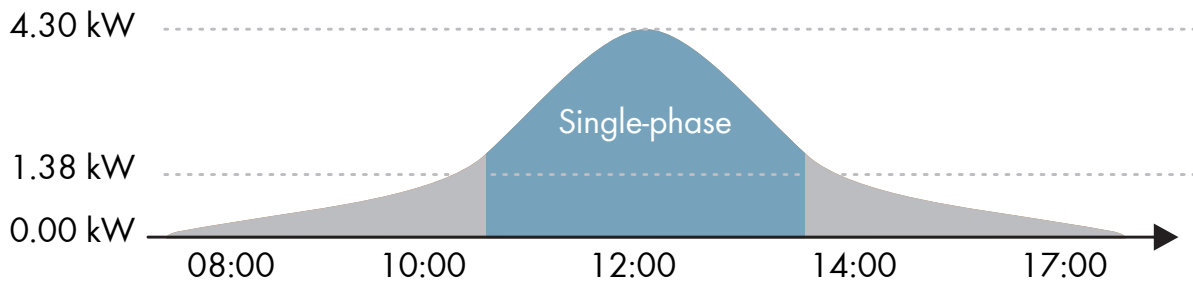

Figure 27: Use of self-generated PV energy even with low irradiation/few hours of sunshine thanks to single-phase operation.

9.13.2 Authorizing the charging process via RFID card

Requirements:

- The charging station is ready for operation and the green LED indicator is flashing (see Section 5.6, page 30).
- The RFID card has been taught (see Section 9.11, page 91).
- Charging approval is activated (see Section 9.10, page 91)

Procedure:

1. Connect the charging cable to the vehicle.

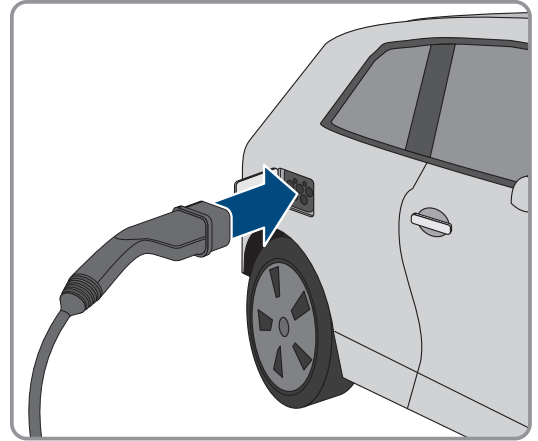

2. Connect the charging cable to the charging station.

Information: In very cold conditions (e.g., -25°C) or when used in snow and ice, more force is required to insert the type 2 connector.

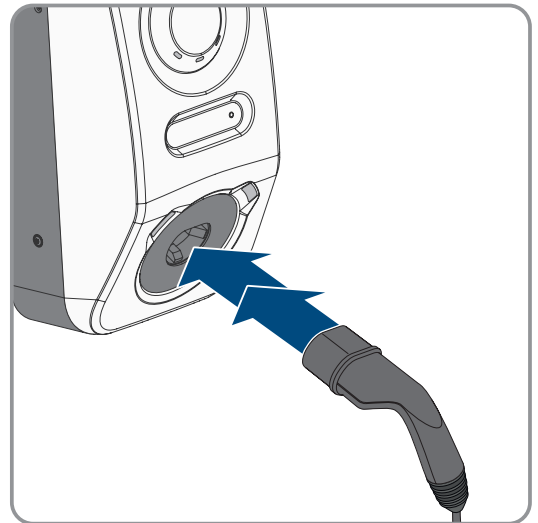

- ☑ The charging cable is locked.
- ☑ The yellow LED lights up. The charging station is locked.

3. **Information:** The Sunny Home Manager 2.0 can schedule loads (e.g., an SMA eCharger) in a price-optimized manner. To make the most of this in connection with dynamic electricity tariffs, the settings in Sunny Portal powered by ennexOS and the SMA Energy App can be optimized.

4. Authorize the charging process. To do so, hold the RFID card up to the sensor for about 10 mm.

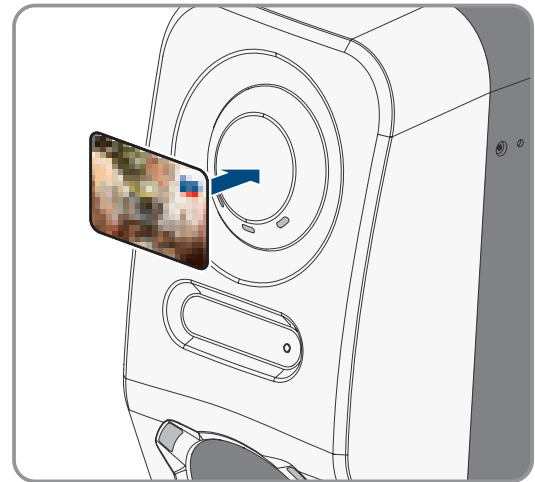

- A rapidly flashing yellow LED indicates that the authorization required for the charging process was successful.
 - The green LED flashes slowly.
 - The charging station is now ready for use. Depending on which charging mode has been selected, the charging process starts immediately or is delayed as specified by the energy manager.
5. Knocking twice on the sensor activates the fast charging function (see Section 5.3, page 26).

See also the following video for additional information:

TechTip: Register RFID cards on the SMA eCharger and authorize the charging process



TechTip: Register RFID cards on the SMA eCharger and authorize charging processes



Also see:

- [Properties of Charging Modes](#) ⇒ page 92

9.13.3 Authorizing the charging process via Energy App

Requirement:

- The charging station is ready for operation and the green LED indicator is flashing (see Section 5.6, page 30).
- The SMA Energy App is installed on your smart device and open.
- Charging approval is activated (see Section 9.10, page 91)

Procedure:

1. Connect the charging cable to the vehicle.

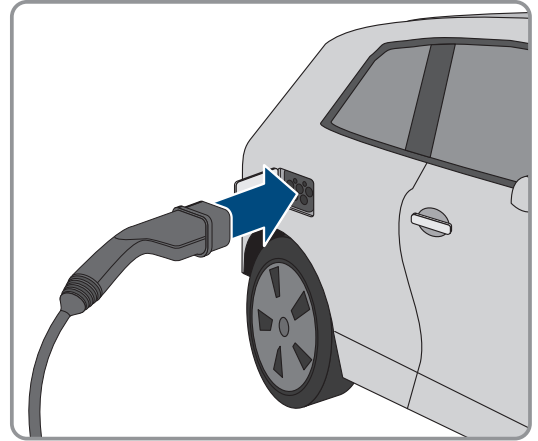

2. Connect the charging cable to the charging station.

Note: At low temperatures (-25 °C), more force is needed to plug in the type 2 connector.

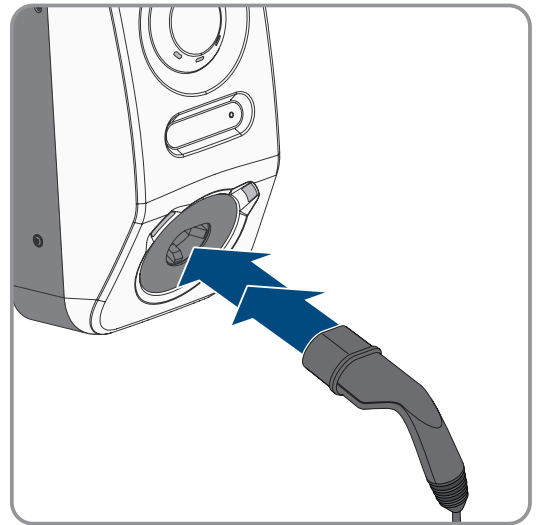

- ☑ The charging cable is locked.
 - ☑ The yellow LED lights up. The charging station is locked.
3. Authorize the charging process. To do so, open the "E-mobility" tab in the SMA Energy App and unlock the charging station by swiping from left to right.
 - ☑ A rapidly flashing yellow LED indicates that the authorization required for the charging process is successful.
 - ☑ The green LED flashes slowly.
 - ☑ The charging station is now ready for use. Depending on which charging mode has been selected, the charging process starts immediately or is delayed as specified by the energy manager.

Also see:

- [Properties of Charging Modes](#) ⇒ page 92
- [Product Description](#) ⇒ page 26

9.13.4 Ending the Charging Process

You have two options to stop the charging process:

- Open the SMA Energy App and select **Stop charging**.
- Stop the charging process at the vehicle (see manufacturer's manual). Ensure that the charging process is properly stopped at the vehicle and that the charging socket is unlocked by the vehicle before the charging cable is pulled out. As a result, damage to the charging cable or the connector on the vehicle is avoided.

i **Charging cable cannot be disconnected from charging station**

The charging cable remains connected to the charging station if the parameter **Lock the charging cable to the charging station** is activated.

i **In case of a grid failure, the mechanical lock on the charging cable at the charging station automatically opens.****i** **Storing the charging cable**

Always store the charging cable in a dry place, not on the ground, and inspect the contacts regularly.

- Incorrect or inappropriate storage leads to corrosion of the charging cable contacts. This voids any warranty claims.

Also see:

- [Configure device](#) ⇒ page 85

10 Disconnecting the product from voltage sources

⚠ QUALIFIED PERSON

Prior to performing any work on the product, always disconnect it from all voltage sources as described in this section. Always adhere to the prescribed sequence.

⚠ WARNING

Danger to life due to electric shock from destruction of the measuring device due to overvoltage

Overvoltage can damage a measuring device and result in voltage being present in the enclosure of the measuring device. Touching the live enclosure of the measuring device results in death or lethal injuries due to electric shock.

- Only use measuring devices with measurement ranges designed for the maximum AC voltage of the charging station.

Procedure:

1. Disconnect the AC miniature circuit breaker and secure against reconnection.
2. If the multifunction relay is used, switch off any supply voltage to the load.
3. Switch off the supply voltage of the digital signal sources if necessary.
4. Remove any charging cable that may be connected.
5. Wait until the LEDs have gone out.
6. Unscrew the two socket head cap screws (M5 x 8) of the housing cover (TX25).

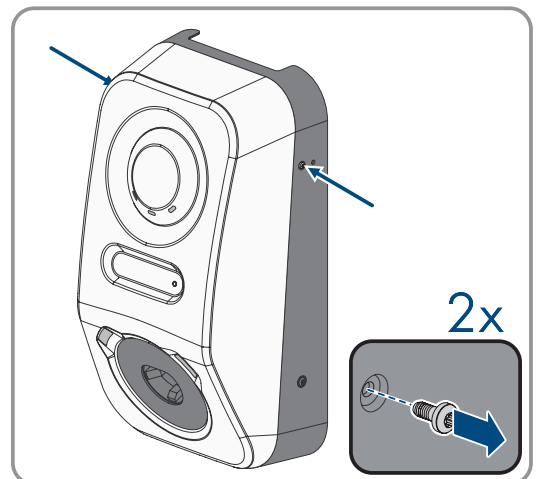

7. Release the locking tabs at the top of the cover of the enclosure with a suitable tool ($<\varnothing 5\text{mm}$).

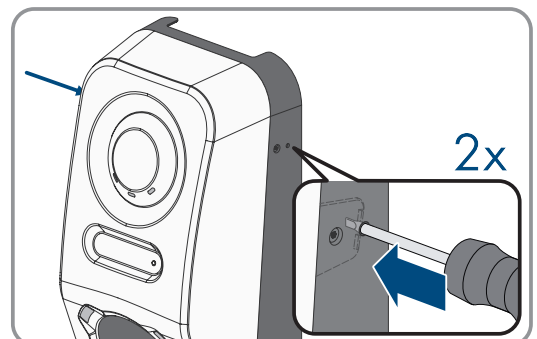

8. Tilt the cover forward to an angle of about 70° and then carefully pull upwards to remove it.

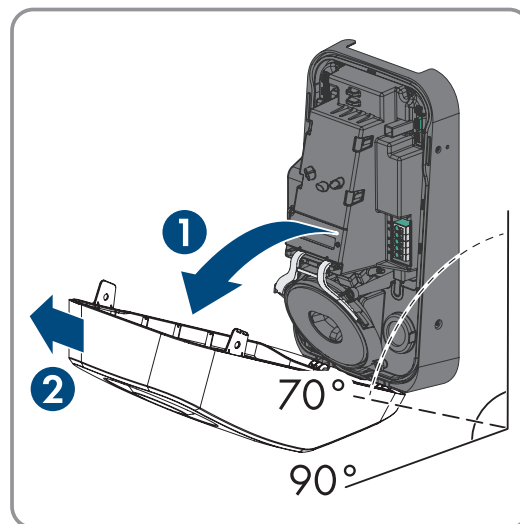

9. Set the screws and the enclosure lid aside and store safely.

10. Check that there is no voltage between L1 and N, L2 and N, and L3 and N at the AC terminal block for connecting the utility grid. Use a suitable measuring device for this purpose. To do this, insert the test probes through the openings on the terminal block.

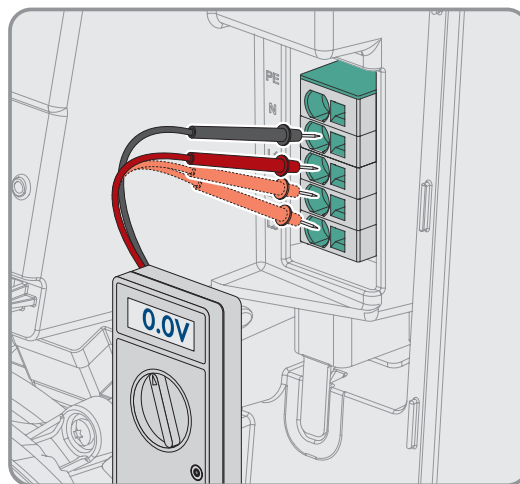

11. Check that there is no voltage between L1 and grounding conductor, L2 and grounding conductor, and L3 and grounding conductor at the AC terminal block for connecting the utility grid. Use a suitable measuring device for this purpose.

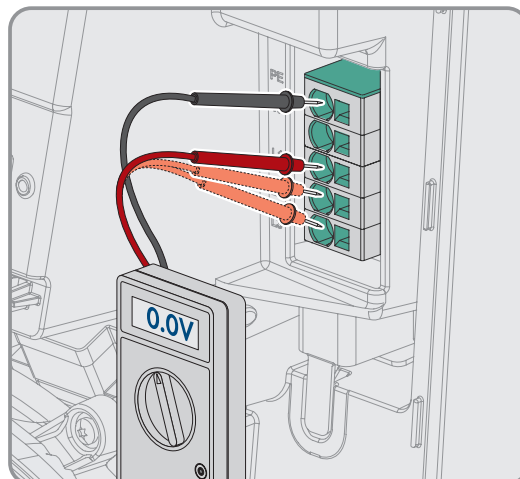

11 Maintenance

QUALIFIED PERSON

DANGER

Danger to life due to electric shock when live components or cables are touched

High voltages are present in the conductive components or cables of the product. Touching live parts and cables results in death or lethal injuries due to electric shock.

- Do not touch non-insulated parts or cables.
- Disconnect the product from voltage sources and ensure it cannot be reconnected before working on the device.
- Wear suitable personal protective equipment for all work on the product.

Damage to the product

SMA Solar Technology AG recommends a daily visual inspection by the charging station user. The product and the associated components must not display any damage.

- In the case of damage to the product, contact the installer.

Correct performance of maintenance work

All maintenance work must be performed as described in this document. Deviations from procedures or failure to comply with the maintenance intervals will lead to any guarantee- or warranty claims becoming null and void.

Perform maintenance at intervals in accordance with locally applicable laws, regulations, standards, and directives.

Failure to comply with maintenance intervals can cause personal injury or property damage.

Procedure:

1. Ensure that the residual current operated circuit-breaker with integral overcurrent protection (RCBO) is working.
2. Ensure that the tripping time and operating current of the individual, active conductors are correct.
3. Ensure that the protection devices at the network input of the charging station are working.

12 Cleaning

The product must be cleaned regularly to ensure that the product is free of dust, leaves, moisture, and other dirt.

NOTICE

Damage to the product due to cleaning agents

The use of cleaning agents may cause damage to the product and its components.

- Clean the product and all its components only with a cloth moistened with clear water.

13 Troubleshooting

13.1 Create Diagnostics Data

Download the diagnostic data of the device in case of failure. Diagnostic data makes it easier for SMA Service to analyze errors.

Requirement:

- The user interface must be open and you must be logged in.

Procedure:

1. Select the product in the focus navigation.
2. In the **Monitoring** menu, select **Diagnostics**.
3. Select **Diagnostic data**.
4. Select the required values and click [**Download**].
5. Provide diagnostic data to the SMA Service in encrypted form.

13.2 Event messages

13.2.1 Event 901

QUALIFIED PERSON

Event message:

- PE connection missing
- Check connection

Explanation:

Starting from firmware version **2.5.29.R**, the parameter **Ground connection monitoring** is available. This function monitors whether the grounding conductor is correctly connected to the grid when it is enabled (in the standard case).

Corrective measures:

- Ensure that the grounding conductor is correctly connected.
- If the SMA eCharger is connected to a utility grid where the grounding conductor is missing (e.g., a delta IT system), set the parameter to [**No**].
- After setting the parameter, restart the SMA eCharger.

13.2.2 Event 1302

QUALIFIED PERSON

Event message:

- Waiting for grid voltage
- Grid connection installation failure
- Check grid and fuses

Explanation:

Either L or N is not connected, or the utility grid has failed.

Corrective measures:

- Ensure that there is no utility grid failure.

- Ensure that the line conductors are connected.
- Ensure that the miniature circuit breaker is switched on.
- Ensure that the AC cable is not damaged and that it is connected correctly.

13.2.3 Event 1416

QUALIFIED PERSON

Event message:

- Grid incident

Explanation:

Due to a voltage imbalance between the line conductors, the system disconnects from the utility grid.

Corrective measures:

- Eliminate any faults in the installation.

13.2.4 Event 3701

QUALIFIED PERSON

Event message:

- **Residual current too high**

Explanation:

A DC residual current has been detected between the product and vehicle.

Corrective measures:

- Check the user interface of the vehicle for an error message.
- Disconnect the product from the vehicle and reconnect to reset the error message.

13.2.5 Event 6202

QUALIFIED PERSON

Event message:

- Self-diagnostics > DI converter fault

Explanation:

The external component DI converter reports an error.

Corrective measures:

- Only contact the service department if the problem persists.

13.2.6 Event 6501

QUALIFIED PERSON

Event message:

- **Self-diagnosis**
- **Overtemperature**

Explanation:

The product has switched off because the internal temperature is above the maximum permissible value.

Corrective measures:

- Wait until the product has cooled down.
- If this message is displayed frequently, contact the Service.

13.2.7 Event 6603**⚠ QUALIFIED PERSON****Event message:**

- Self-diagnosis
- Overcurrent grid (HW)

Explanation:

The cause must be determined by the Service.

Corrective measures:

- Contact Service.

13.2.8 Event 6630**⚠ QUALIFIED PERSON****Event message:**

- Overcurrent at point of interconnection, quick stop triggered

Explanation:

- An overcurrent has been detected at the connection point. This triggered a fast stop.

13.2.9 Event 7001**⚠ QUALIFIED PERSON****Event message:**

- Fault sensor interior temperature

Explanation:

A temperature sensor in the product is faulty. The cause must be determined by the Service.

Corrective measures:

- Contact Service.

13.2.10 Event 7312**⚠ QUALIFIED PERSON****Event message:**

- Update completed

13.2.11 Event 7320**⚠ QUALIFIED PERSON****Event message:**

- The device was successfully updated

Explanation:

The firmware update was completed successfully.

13.2.12 Event 7321**⚠ QUALIFIED PERSON****Event message:**

- Error when transferring the Firmware update Version number ## Procedure aborted.

Explanation:

The firmware update was not successful.

Corrective measures:

- Retry update.
- If this message is displayed again, contact the Service.

13.2.13 Event 7330**Event message:**

- **Wait for update conditions**

Explanation:

The testing of the update conditions was not successful. The firmware update package is not suitable for this product.

Corrective measures:

- Retry update.
- Ensure that the selected update file is suitable for this product.
- If this message is displayed again, contact the Service.

13.2.14 Event 7333**⚠ QUALIFIED PERSON****Event message:**

- **Update transport failed**

Explanation:

The update file could not be copied to the internal memory of the product. In the event of a connection to the product via Wi-Fi, poor connection quality may be the cause.

Corrective measures:

- Retry update.
- For Wi-Fi connection: Improve the Wi-Fi connection quality (e.g., via Wi-Fi repeater) or establish connection with the product via Ethernet.
- If this message is displayed again, contact the Service.

13.2.15 Event 7347**⚠ QUALIFIED PERSON****Event message:**

- **Incompatible file**

Explanation:

The configuration file is not suitable for this product.

Corrective measures:

- Ensure that the selected configuration file is suitable for this product.
- Retry import.

13.2.16 Event 7348**⚠ QUALIFIED PERSON****Event message:**

- **Incorrect file format**

Explanation:

The configuration file is not of the required format or is damaged.

Corrective measures:

- Ensure that the selected configuration file is of the required format and is not damaged.
- Retry import.

13.2.17 Event 7605**Event message:**

- Communication error power unit

Explanation:

The product has detected an internal communication error.

Corrective measures:

- Contact Service.

13.2.18 Event 7609**⚠ QUALIFIED PERSON****Event message:**

- Communication with (tr0) is faulty.

Explanation:

The product has detected a communication error.

Corrective measures:

- Contact Service.

13.2.19 Event 7619**⚠ QUALIFIED PERSON****Event message:**

- **Communication fault with meter unit**
- **Check communication to meter**

Explanation:

The product is not receiving any data from the energy meter.

Corrective measures:

- Ensure that the energy meter is correctly integrated into the same network as the product (see energy meter manual).
- SMA Solar Technology AG recommends connecting the product to the local network via Ethernet.

13.2.20 Event 7637**⚠ QUALIFIED PERSON****Event message:**

- Communication to internal energy meter disturbed

Explanation:

The product has detected a communication error of internal energy meter.

Corrective measures:

- Contact Service.

13.2.21 Event 7639**⚠ QUALIFIED PERSON****Event message:**

- Communication with (tn0) is faulty.

Explanation:

The product has detected a communication error.

Corrective measures:

- Contact Service.

13.2.22 Event 7702**⚠ QUALIFIED PERSON****Event message:**

- Self-diagnosis
- Interference device

Explanation:

The cause must be determined by the Service.

Corrective measures:

- Contact Service.

13.2.23 Event 8003**⚠ QUALIFIED PERSON****Event message:**

- Temperature derating

Explanation:

The product has reduced its power due to excessive temperature for more than 10 minutes (derating) or has disconnected from the utility grid. This behavior can occur at high ambient temperatures and does not indicate an error in this case.

Corrective measures:

- Clean the cooling fins on the rear of the enclosure and the air ducts on the top using a soft brush.
- If fans are present, check them for dirt and clean if necessary. Run the fan test via the web interface.
- Ensure that the product is ventilated adequately.
- Ensure the maximum ambient temperature is not exceeded.
- Ensure that the installation conditions are complied with.

13.2.24 Event 8709**⚠ QUALIFIED PERSON****Event message:**

- **Timeout in communication for reactive power spec.**

Explanation:

Communication to the system control absent. Depending on the fallback setting, either the last received values will be retained or the active power will be limited to the set percentage value of the inverter nominal power.

Corrective measures:

- Ensure that the connection to the System Manager is intact and that no cables are damaged or that no plugs have been pulled.

13.2.25 Event 8710**⚠ QUALIFIED PERSON****Event number:**

- **Timeout in communication for cos-Phi spec.**

Explanation:

Communication to the system control absent.

Corrective measures:

- Ensure that the connection to the System Manager is intact and that no cables are damaged or that no plugs have been pulled.

13.2.26 Event 9026**⚠ QUALIFIED PERSON****Event message:**

- Fast stop

Explanation:

An overcurrent has been detected at the connection point. This triggered a fast stop.

13.2.27 Event 9102

QUALIFIED PERSON

Event message:

- Permanent operation inhibition

Explanation:

The charging and discharging operation of the inverter is permanently interrupted.

Corrective measures:

- Set the parameter **Operating mode** to **Start**.

13.2.28 Event 9801

QUALIFIED PERSON

Event message:

- Vehicle not compatible

Explanation:

The vehicle is not suited for use with the EV Charger.

Corrective measures:

- Ensure that the vehicle is suited for use with the EV Charger.
- Try action again.

13.2.29 Event 9802

QUALIFIED PERSON

Event message:

- Vehicle signals charging error

Explanation:

The vehicle has detected an error during the charging mode.

Corrective measures:

- Open and close the vehicle by radio remote control.
- Remove the charging cable from the vehicle and then reconnect the charging cable to the vehicle.
- Check and if necessary adjust the settings in the vehicle's user interface.

13.2.30 Event 9803

QUALIFIED PERSON

Event message:

- Communication problems between charging station and vehicle

Explanation:

No communication can be established between EV Charger and vehicle.

13.2.31 Event 9804

QUALIFIED PERSON

Event message:

- Charging station switches to charging mode [##]

Explanation:

The charging mode was changed to the displayed mode.

13.2.32 Event 9805

QUALIFIED PERSON

Event message:

- Charging mode was interrupted by vehicle.

Explanation:

The charging process was interrupted by the vehicle or the charging station.

Corrective measures:

- Opening and closing of the vehicle by radio remote control.
- Remove the charging cable from the vehicle and then reconnect the charging cable to the vehicle.
- Check and if necessary adjust the settings in the vehicle's user interface.

13.2.33 Event 9806

QUALIFIED PERSON

Event message:

- A proximity pilot fault has occurred in the charging cable, the charging cable does not meet any specification, or is defective.

Corrective measures:

- Use appropriate charging cable.

13.2.34 Event 9807

QUALIFIED PERSON

Event message:

- The charging port cannot be locked.

Corrective measures:

- Check the plug connections and plug in the cable until it stops. If the event persists, contact Service and have the parameters and diagnostic data ready.

13.2.35 Event 9808

QUALIFIED PERSON

Event message:

- The charging port cannot be unlocked.

Corrective measures:

- Turn off the AC circuit breaker to open the lock.

13.2.36 Event 9809**⚠ QUALIFIED PERSON****Event message:**

- The locked/unlocked status cannot be determined.

Corrective measures:

- Restart the device.
- Contact Service.

13.2.37 Event 9810**⚠ QUALIFIED PERSON****Event message:**

- The PWM signal to the vehicle does not reach the amplitude of -12 volts.

Corrective measures:

- Test on a different vehicle or check with a test adapter.
- Contact Service.

13.2.38 Event 9811**⚠ QUALIFIED PERSON****Event message:**

- The charging controller reports an undefined error.

Corrective measures:

- Restart the device.
- Contact Service.

13.2.39 Event 9812**⚠ QUALIFIED PERSON****Event message:**

- Charging process started with card name

13.2.40 Event 9813**⚠ QUALIFIED PERSON****Event message:**

- Charging process completed, xx.xx kWh charged

13.2.41 Event 9814

QUALIFIED PERSON

Event message:

- Card (RFID-UUID) rejected

Corrective measures:

- Teach RFID card.
- Contact Service.

13.2.42 Event 9815

QUALIFIED PERSON

Event message:

- Card (RFID UUID) successfully registered

13.2.43 Event 9905

QUALIFIED PERSON

Event message:

- Energy Management

Explanation:

Energy Management cannot be enabled because activations are limited.

Corrective measures:

- Contact Service.

13.2.44 Event 9908

QUALIFIED PERSON

Event message:

- Energy Management

Explanation:

This message is displayed if validation of a cloud plan received from Sunny Portal fails. [0] contains the exact error message or the reason for the validation failure.

Corrective measures:

- Contact Service.

13.2.45 Event 9909

QUALIFIED PERSON

Event message:

- Energy Management

Explanation:

This message appears if the fallback cloud plan could not be saved in the system and all changes made during the process have been rolled back.

Corrective measures:

- Contact Service.

13.2.46 Event 10002**⚠ QUALIFIED PERSON****Event message:**

- Restart

Explanation:

The product is performing a restart.

13.2.47 Event 10005**⚠ QUALIFIED PERSON****Event message:**

- Start-up

Explanation:

A system start is carried out.

13.2.48 Event 10100**⚠ QUALIFIED PERSON****Event message:**

- Parameter [##] set successfully. [##] to [##]

Explanation:

The displayed parameter was successfully changed.

13.2.49 Event 10101**⚠ QUALIFIED PERSON****Event message:**

- Setting of parameter [##] failed. [##] to [##]

Explanation:

The displayed parameter was not changed.

Corrective measures:

- Make sure thresholds of the parameters are complied with.
- Change the parameter again.

13.2.50 Event 10107

QUALIFIED PERSON

Event message:

- Update failed

Explanation:

The update was not carried out successfully.

Corrective measures:

- Retry update.
- If this message is displayed again, contact the Service.

13.2.51 Event 10109

QUALIFIED PERSON

Event message:

- Time adjusted / new time

13.2.52 Event 10111

QUALIFIED PERSON

Event message:

- Update to version ## successful

Explanation:

The firmware update was completed successfully.

13.2.53 Event 10114

QUALIFIED PERSON

Event message:

- The device has been reset to the factory setting.

Explanation:

The configuration of the product has been reset to the default settings.

13.2.54 Event 10207

QUALIFIED PERSON

Event message:

- New device [##] registered

Explanation:

The displayed product was included in the system of the communication product.

13.2.55 Event 10222

QUALIFIED PERSON

Event message:

- Parameter change for parameter # was initiated by user # via EVC###AC-10 from value # to #.

Explanation:

Parameter change was initiated.

13.2.56 Event 10270

QUALIFIED PERSON

Event message:

- Communication fault with Sunny Home Manager

Explanation:

No communication connection to the Sunny Home Manager can be established.

Corrective measures:

- Ensure that the energy meter is correctly integrated into the same network as the product (see energy meter manual).
- Connect the energy meter directly to the second Ethernet port of the product.
- For Wi-Fi connection: Improve the Wi-Fi connection quality (e.g., via Wi-Fi repeater) or connect the product with the DHCP server (router) via Ethernet.

13.2.57 Event 10283

QUALIFIED PERSON

Event message:

- WiFi module faulty

Explanation:

The Wi-Fi module integrated in the product is defective.

Corrective measures:

- Contact Service.

13.2.58 Event 10284

QUALIFIED PERSON

Event message:

- No WiFi connection possible

Explanation:

The product does not currently have a Wi-Fi connection to the selected network.

Corrective measures:

- Ensure that the SSID, the Wi-Fi password and the encryption method have been entered correctly. The encryption method is specified by your Wi-Fi router or Wi-Fi access point and can be changed there.
- Ensure that the Wi-Fi router or Wi-Fi access point is in range and is signaling correct operation.

- If this message is displayed often, improve the Wi-Fi connection by using a Wi-Fi repeater.

13.2.59 Event 10285

QUALIFIED PERSON

Event message:

- WiFi connection established

Description:

Connection to the selected Wi-Fi network has been established.

13.2.60 Event 10286

QUALIFIED PERSON

Event message:

- Wi-Fi connection lost

Explanation:

The product has lost Wi-Fi connection to the selected network.

Corrective measures:

- Ensure that the Wi-Fi router or Wi-Fi access point is still active.
- Ensure that the Wi-Fi router or Wi-Fi access point is in range and is signaling correct operation.
- If this message is displayed often, improve the Wi-Fi connection by using a Wi-Fi repeater.

13.2.61 Event 10294

QUALIFIED PERSON

Event message:

- Access point activated

Explanation:

The access point is active. A Wi-Fi connection can be established.

13.2.62 Event 10295

QUALIFIED PERSON

Event message:

- Access point is deactivated

Explanation:

The access point is not active. No Wi-Fi connection could be established.

13.2.63 Event 10321

QUALIFIED PERSON

Event message:

- Communication with device currently not possible. Device may be switched off.

13.2.64 Event 10507

QUALIFIED PERSON

Event message:

- New active power limit

Explanation:

The product has received a new specification for active power limitation.

13.2.65 Event 10603

QUALIFIED PERSON

Event message:

- Invalid configuration for the mains consumption counter

13.2.66 Event 10612

QUALIFIED PERSON

Event message:

- The administrator account has been reset

13.2.67 Event 27201

QUALIFIED PERSON

Event message:

- Search for update completed successfully

13.2.68 Event 27204

QUALIFIED PERSON

Event message:

- Download of an update started

13.2.69 Event 27205

QUALIFIED PERSON

Event message:

- Update download successful

13.2.70 Event 27206

QUALIFIED PERSON

Event message:

- Download of update not completed successfully

Explanation:

The download of an update has failed.

Corrective measures:

- Try downloading the update again.
- For Wi-Fi connection: Improve the Wi-Fi connection quality (e.g., via Wi-Fi repeater) or establish connection with the product via Ethernet.
- If this message is displayed again, contact the Service.

13.2.71 Event 27208** QUALIFIED PERSON****Event message:**

- Transfer of the Firmware update Version number [##] for device type [##]. The transfer can take some time.

13.2.72 Event 27313** QUALIFIED PERSON****Event message:**

- Update started

14 Decommissioning the Product

⚠ QUALIFIED PERSON

To decommission the charging station completely at the end of its service life, proceed as described in this section.

⚠ CAUTION

Risk of injury due to weight of product

Injuries may result if the product is lifted incorrectly or dropped while being transported or mounted.

- Transport and lift the product carefully. Take the weight of the product into account.
- Wear suitable personal protective equipment for all work on the product.

Procedure:

1. Disconnect the charging station from voltage sources (see Section 10, page 99).
2. Insert a screwdriver into the openings on the terminal blocks and remove the AC cable.
3. If the multifunction relay is used, remove the connection cable from the charging station.
4. If other cables (e.g., network cables or signal cables) are connected, remove them from the charging station.
5. Close the enclosure lid of the charging station (see Section 7.10, page 70).
6. Unscrew the two screws that attach the charging station to the mounting bracket using a screwdriver (TX25).
7. Carefully remove the charging station from the wall or charging station column.
8. Remove the mounting bracket from the wall or charging station column. To do so, loosen the four screws using a suitable tool.
9. If the charging station is to be stored or shipped in packaging, pack the charging station. Use the original packaging or packaging that is suitable for the weight and dimensions of the charging station.

15 Replacing the Product

QUALIFIED PERSON

Under fault conditions, an SMA product in the system may need to be replaced. If this is the case, you will receive a replacement device from SMA Solar Technology AG. If you received a replacement device, replace the defective product with the replacement device as described below.

1. Decommission the defective product.
2. Mount the replacement device and make the electrical connections.
3. Commission the replacement device.
4. If the defective product was registered by a System Manager (e.g., an inverter configured as a System Manager) or by a communication product, replace it with the new product in the System Manager or communication product (see the Communication Product or System Manager manual).
5. If the System Manager has been replaced, confirm the replaced device in Sunny Portal (see Sunny Portal manual)
6. Pack the defective product in the packaging of the replacement device and arrange with SMA Solar Technology AG for it to be picked up. If a mounting bracket is enclosed with the replacement device, pack it with the defective product.

16 Disposal

The product must be disposed of in accordance with the locally applicable disposal regulations for waste electrical and electronic equipment.



17 Technical Data

17.1 Inputs and outputs (AC)

Charge power (mode 3)	1.38 kW to 22 kW (configurable) Password-protected limit on the maximum charging power is possible, e.g. to 11 kW
Nominal voltage	1N \tilde , AC, 230 V (as of firmware version 2.5.x.R) / 3N \tilde , AC, 400 V
Nominal frequency	50 Hz / 60 Hz
Nominal current	max. 32 A per line conductor
Conductor cross-section, rigid	5 x 2.5 mm ² to 5 x 10 mm ²
Conductor cross-section, flexible	5 x 2.5 mm ² to 5 x 6 mm ²
Vehicle connection	Type 2 charging socket with integrated shutter

17.2 Communication

Ethernet	10/100 Mbit/s (2 Ports)
Wi-Fi	WLAN 802.11 b/g/n
RS485	Available
Vehicle communication	IEC 61851-1/2 Mode 3, ISO 15118 (function in preparation)
OCPP	Function in preparation

17.3 Protective Devices

Internal DC residual current detection	6 mA functional according to IEC 61851-1
Compatibility with external residual-current devices	RCD type A \leq 30 mA according to IEC 61851-1
Power outage protection	in combination with compatible energy meter

17.4 General Data

Width x height x depth	270 mm x 495 mm x 190 mm
Weight	5 kg
Length x width x height of the packaging	600 mm x 400 mm x 300 mm
Transport weight	7 kg
Climatic category in accordance with IEC 60721-3-4	4K26
Environmental category	outdoors
Pollution degree of all enclosure parts	2
Operating temperature range	-25°C to +50°C with infinitely variable derating

Storage temperature range	-25 °C to +70 °C
Max. permissible value for relative humidity (condensing)	95 %
Maximum operating altitude above mean sea level (MSL)	2000 m
Typical noise emission	Silent operation
Standby self-consumption	< 6.5 W
Cooling method	Convection
Degree of protection for electronics in accordance with IEC 60529	IP54 / IK10
Protection class (in accordance with IEC 62103) / Over-voltage category	I / III
Radio technology	WLAN 802.11 b/g/n
Radio spectrum	2.4 GHz
Maximum transmission power	100 mW
Wi-Fi range in free-field conditions	maximum 100 m
Quantity maximum detectable Wi-Fi networks	32
Grid configurations	TN / TT / IT

17.5 Equipment

AC terminal	Spring-cage terminal
Speedwire interface	As standard
Wi-Fi	As standard
RS485	As standard
Integrated energy meter	Energy meters of accuracy class C as per DIN EN 50470
Authorization	RFID in accordance with standards ISO IEC 14443
Data logs	SEMP, SMA Modbus
System compatibility (as of November 2023)	Webconnect, SMA Sunny Home Manager 2.0
RFID cards (MIFARE DESFIRE EV3)	2x RFID cards included
SMA Smart Connected	As standard

17.6 Digital inputs

Digital inputs

Quantity	6
----------	---

Input voltage	12 V DC
Maximum cable length	30 m

17.7 Digital output (multifunction relay)

Quantity	1
Execution	Potential-free relay contacts
Maximum switching voltage	30 V _{DC}
Maximum switching current (ohmic load)	1 A
Minimum switching current	10 mA
Minimum electrical endurance when the maximum switching voltage and maximum switching current are complied with ²⁾	100,000 switching cycles
Bounce time	5 ms
Reset time	5 ms
Maximum cable length	30 m

17.8 Data Storage Capacity

1-minute values	7 days
5-minute values	7 days
Fifteen-minute values	30 days
60-minute values	3 years
Event messages	100,000 events

17.9 Climatic Conditions

Installation in accordance with IEC 60721-3-4, Class 4K26

Extended humidity range	0% to 95%
Threshold for relative humidity, non-condensing	95 %

Transport in accordance with IEC 60721-3-4, Class 2K12

Temperature range	-25 °C to +70 °C
-------------------	------------------

17.10 Torques

Screws wall mounting	Hand-tight
Enclosure screws (TX25)	2.2 Nm ± 0.2 Nm
Enclosure lid screws (TX25)	2.2 Nm ± 0.2 Nm

²⁾ Corresponds to 20 years at 12 switching operations per day

18 Accessories

You will find the accessories for your product in the following overview. If required, these can be ordered from SMA Solar Technology AG or your distributor.

A

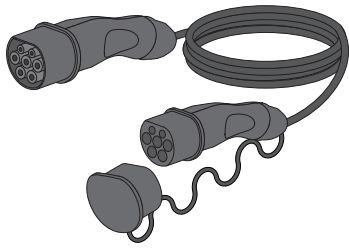

EVC-CBL-3-5-20

B

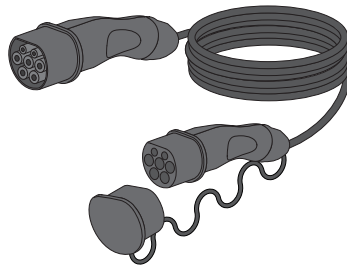

EVC-CBL-3-7.5-20

C

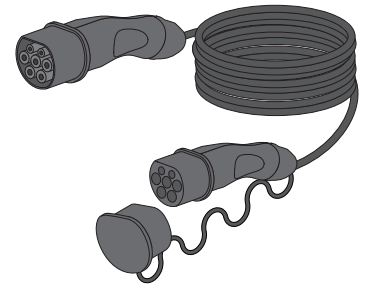

EVC-CBL-3-10-20

D



EVC-RFID-10-10

E

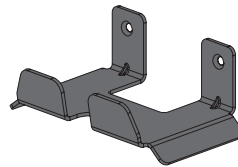

EVC-CBL-HLD-10

F

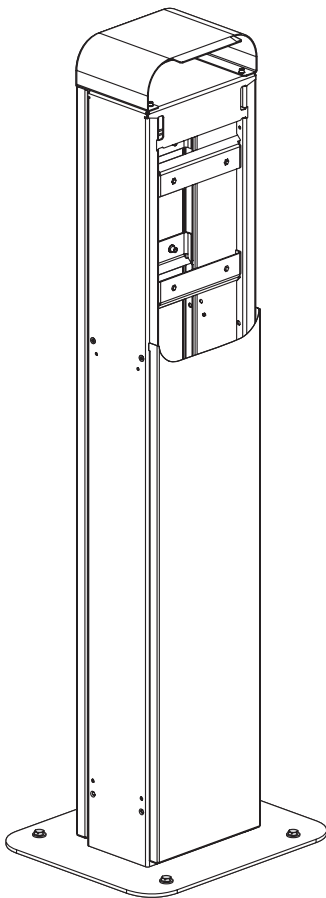

EVC-PDSTL-1-20

G

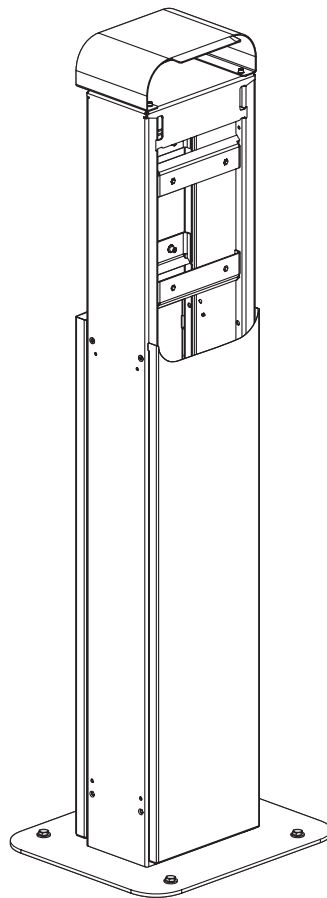

EVC-PDSTL-2-20

H

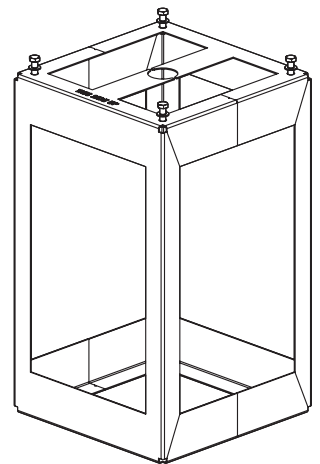

EVC-GD-PDSTL-10

Position	Designation	Description	SMA order number
A	5.0 m mobile AC Charging Cable Type 2	Three-phase AC charging cable in 5.0 m lengths for the SMA eCharger type EVC22-3AC-20 and SMA EV Charger Business type EVCB-LB-3AC-10 and EVCB-LB-3AC-ECC-10	EVC-CBL-3-5-20
B	7.5 m mobile AC Charging Cable Type 2	Three-phase AC charging cable in 7.5 m lengths for the SMA eCharger type EVC22-3AC-20 and SMA EV Charger Business type EVCB-LB-3AC-10 and EVCB-LB-3AC-ECC-10	EVC-CBL-3-7.5-20
C	10.0 m mobile AC Charging Cable Type 2	Three-phase AC charging cable in 10.0 m lengths for the SMA eCharger type EVC22-3AC-20 and SMA EV Charger Business type EVCB-LB-3AC-10 and EVCB-LB-3AC-ECC-10	EVC-CBL-3-10-20
D	RFID charging cards (pack of 10)	RFID charging cards as accessories, 10 charging cards for SMA eCharger and SMA EV Charger Business, NXP Mifare Desfire EV3	EVC-RFID-10-10
E	Charging cable holder	Charging cable holder for wall mounting of the SMA eCharger	EVC-CBL-HLD-10
F	Charging station column of SMA eCharger (single-sided)	Charging station column of SMA eCharger (single-sided) Robust mounting pole for freestanding, single-sided installation of an SMA eCharger (EVC22-3AC-20)	EVC-PDSTL-1-20
G	Charging station column of SMA eCharger (double-sided)	Charging station column of SMA eCharger (double-sided) Robust mounting pole for free-standing, double-sided installation of two SMA eChargers (EVC22-3AC-20)	EVC-PDSTL-2-20
H	Embedded section for charging stand installation	Embedded section for charging stand installation: Mounting frame to anchor the charging stand of the SMA eCharger (single-sided/double-sided) into the ground	EVC-GD-PDSTL-10

19 Contact

If you experience any technical problems with our products, please contact the Service. The following data is required in order to provide you with the necessary assistance:

- Device type
- Serial number
- Firmware version
- Device configuration (as stand-alone device or with Sunny Home Manager 2.0)
- Special country-specific settings (if available)
- Event message
- Installation site and mounting height
- Optional equipment (e.g. accessories used)
- Use the name of the system in Sunny Portal (if available)
- Access data for Sunny Portal (if available)
- Information on the ripple control receiver (if available)
- Operating mode of the multifunction relay (if used)
- Detailed description of the problem (have parameters ready in CSV format)

You can find your country's contact information at:



<https://go.sma.de/service>

20 EU Declaration of Conformity

within the scope of the EU directives



- Radio Equipment Directive 2014/53/EU (22.5.2014 L 153/62) (RED)
- Restriction of the use of certain hazardous substances 2011/65/EU (L 174/88, June 8, 2011) and 2015/863/EU (L 137/10, March 31, 2015) (RoHS)

SMA Solar Technology AG confirms herewith that the products described in this document are in compliance with the fundamental requirements and other relevant provisions of the aforementioned directives. More information on the availability of the entire Declaration of Conformity can be found at <https://www.sma.de/en/ce-ukca>.

Radio technology	WLAN 802.11 b/g/n
Radio spectrum	2.4 GHz
Maximum transmission power	100 mW
Radio technology	RFID / NFC
Radio spectrum	13,56 MHz
Maximum transmission power	max. 60dB μ A/m at 10 m

ENERGY
THAT
CHANGES



www.SMA-Solar.com

