

15° L
1676

Units of length L in mm

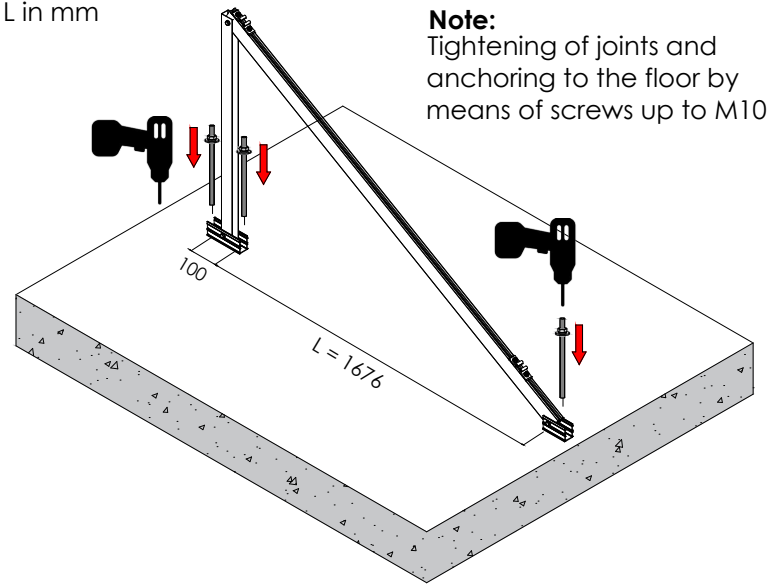
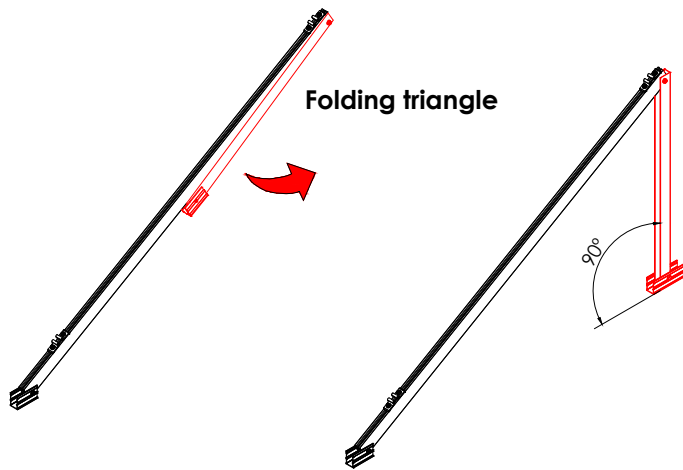

Note:
Tightening of joints and anchoring to the floor by means of screws up to M10

Specifications

Description	Triangle for pitched roof and flat roof. Open support for modules up to 2279mm.
Anchor length	See table
Installation surface	Pitched roof and flat roof
Anchoring surface	Concrete
Features	Screws: A2-70 stainless steel Sections: EN AW 6005A T6 (raw or anodised) Vertical module arrangement
Anchoring points	3 Anchoring points (Max. M10)
Compatible profile	G1
Tightening torque	M8 Hexagonal screw: 20Nm
Anchoring screws	Max. M10 (not included)
Inclination	Available for 15°

Necessary tools:



Sunfer Estructuras, S.L.U.

Security:



100%
Recyclable

Marking
ES19/86524 CE

www.sunferenergy.com

Subject to change without notice. Product illustrations are for illustrative purposes only and may differ from the delivered product.