



Model Series: CIESS 25~80 -R-S

Oasis Flex Battery System User Manual

Preface

Thanks for purchasing this product manufactured by Shenzhen Sunwoda Energy Technology Co., Ltd.(hereinafter referred to as Sunwoda).

This manual will provide detailed operating instructions for customers using the Oasis Flex. Please read this manual carefully before using the product and store it properly in a place where it is easily accessible to installation, operation and maintenance personnel.

The contents of this document may be updated from time to time due to product version upgrades or other reasons. Unless otherwise agreed, this document is intended as a product guide only, and all statements, information and recommendations contained in this document do not constitute any warranty, express or implied.

The copyright of this user manual belongs to Sunwoda, and any rights not expressly granted are not reserved. We sincerely hope that our products and manuals will meet your needs. We welcome your valuable comments and will continue to improve and enhance them.

The contents are subject to change without prior notice, please always subject to the latest physical. And for updates or other information, please feel free to contact Sunwoda.

Content



Preface	0
1 Safety Statement	1
1.1 Physical security	1
1.2 Electrical security	1
1.3 Environment security	2
1.4 Mechanical safety	2
1.5 Battery security	3
1.6 Important symbols	4
2 System Introduction	5
2.1 System Overview	5
2.2 Module Dimensions	5
2.2.1 Battery cell	5
2.2.2 Battery box	6
2.2.3 Control box	6
2.3 Module and system parameters	6
2.3.1 Battery cell parameters	6
2.3.2 Battery box parameters	7
2.3.3 Control box parameters	7
2.3.4 System parameters	7
3 Mechanical Installation	12
3.1 Installation Precautions	12
3.2 Accessories Preparation	13
3.3 Installation Procedure	13
3.2.1 Assembly of basic brackets	13
3.2.2 Assemble basic bracket to box	14
3.2.3 Stack the boxes	14
4 Electrical connection	17
Warning Notes:	17
4.1 Cable Introduction	17
4.1.1 Ground cables	17
4.1.2 Power cables	17
4.1.3 Communication cables	19
4.2 Ground connection	20
4.2.1 Connect the A ground cable	20
4.2.2 Connect B and C ground cables	20
4.2.3 Connect the D ground cable	21
4.2.4 Complete schematic of ground cable connection	21
4.3 Power cable connection	23
4.3.1 Connector structure and usage of power cable	23
4.3.2 Connect power cables from battery box to battery box	23
4.3.3 Connect power cable from control box to battery box	24
4.3.4 Connect the power cable from control box to inverter	26
4.3.5 Complete schematic of power cable connection	27
4.4 Communication cable connection	29

4.4.1 Link Port Communication Cable Connection	29
4.4.2 COM port communication cable connection	31
4.4.3 Lan & WAN port communication cable connection	31
4.4.4 Complete diagram of communication cable connection	32
4.5 Parallel wiring(Optional)	34
4.5.1 Ground connection for parallel machines	34
4.5.2 Power cable connections for parallel machines	35
4.5.3 Communication cable connection for parallel machines	36
4.5.5 Complete Wiring Diagram for Parallel Machines	38
5 Trial operation guidance	41
5.1 Description of indicator lights	41
5.2 Power-on precautions	41
5.3 Power-on guidelines	41
5.4 Power-off guidelines	42
6 Product Maintenance and Troubleshooting	43
6.1 System maintenance	43
6.2 Troubleshooting	43
7 Transportation and storage	46
7.1 Transportation requirements	46
7.2 Storage requirements	47



1 Safety Statement

The battery system is a specialised electrical equipment. To ensure correct and safe installation, use and other operations, please read this manual thoroughly before starting operations. The installer should be professionally trained, have a background in electrical technology, and be familiar with local grid codes and related requirements. The Company will not be held liable for any form of damage or injury resulting from failure to follow the operating instructions highlighted in this manual.

1.1 Physical security

 Dangerous	
The installation process is strictly prohibited to operate with electricity. Avoid installing and removing cables with electricity. And the moment the cable core touches the conductor, it will generate electric arc, electric spark or fire and explosion, which can lead to fire or personal injury.	
When the equipment is charged, unregulated and incorrect operation may produce fire, electric shock or explosion, resulting in injury or property damage.	
It is strictly prohibited to wear watches, bracelets, bangles, rings, necklaces and other easily conductive objects during operation to avoid electric shock burns.	
Special insulated tools must be used during operation to avoid electric shock or short-circuit failure, and the insulation voltage withstand level must meet the requirements of local laws, regulations, standards and codes.	
 Warning	
Special protective equipment must be used during operation, such as protective clothing, insulated shoes, goggles, safety helmets and insulated gloves.	

1.2 Electrical security

 Dangerous	
Before making electrical connections, make sure that the equipment is not damaged, otherwise it may cause electric shock or fire.	
Unregulated and incorrect operation may cause accidents such as fire or electric shock.	
During operation, prevent foreign objects entering the equipment, as this may result in short-circuit failure or damage to the equipment, derating or dropping the power supply, and personal injury.	
 Warning	

When installing equipment that requires grounding, the protective earth wire must be installed first; and when removing the equipment, the protective earth wire must be removed last.

1.3 Environment security

Dangerous

Strictly prohibit to put the equipment in the environment of flammable or explosive gas or fume, and prohibit to carry out any operation in this environment.

Never store flammable or explosive materials in the equipment area.

Strictly prohibit the equipment close to heat or fire sources, such as fireworks, candles, heaters or other heat generating equipment, the heat may cause damage to the equipment or even a fire.

Special insulated tools must be used during operation to avoid electric shock or short-circuit failure, and the insulation voltage withstand level must meet the requirements of local laws, regulations, standards and codes.

Warning

The equipment should be installed in an area away from liquids, and it is strictly prohibited to install it under water pipes, air vents and other locations that are prone to condensation; it is also strictly prohibited to install it under air conditioning outlets, ventilation outlets, computer room windows and other locations that are prone to leakage of water, in order to prevent liquids from entering the interior of the equipment and causing equipment malfunctions or short-circuits.

When the equipment is in operation, please do not cover the vent, cooling system or use other items to cover to prevent high temperature damage to the equipment or fire.

1.4 Mechanical safety

Dangerous

Work at height must wear a helmet, safety belt or waist rope, tied to a solid and sturdy structural member, and is strictly prohibited to hang on moving unstable objects or metal with sharp edges, to prevent hooks from slipping off and fall accidents.

Warning

Tools need to be fully prepared and qualified by professional organisations, prohibit the use of scarred and unqualified or beyond the inspection of the validity of the tools to ensure that the tools are solid, not exceed the load.

Before installing the equipment into the cabinet, first make sure that the cabinet has been fixed, to avoid the cabinet because of the unstable centre of gravity, tilting and collapsing, resulting in the installer being smashed, equipment damage and other problems.

Be careful of installing equipment that may be unstable or heavy in the cabinet to avoid being crushed or smashed.

Drilling holes in the equipment is strictly prohibited. Drilling holes will damage the sealing, electromagnetic shielding performance, internal devices and cables of the equipment, and metal shavings from drilling holes into the equipment will lead to a short circuit of the circuit board.

1.5 Battery security

Dangerous

Never short-circuit the positive and negative terminals of the battery, otherwise it will cause a short circuit of the battery. A short circuit of the battery will instantly generate a high current and release a large amount of energy, causing the battery to leak, smoke, release flammable gases, thermal runaway, fire or explosion.

Do not expose the battery to high temperatures or place it around heat generating devices, such as high temperature sunlight, fire sources, transformers, heaters, etc. Overheating of the battery may cause leakage, smoke, release of flammable gases, thermal runaway, fire or explosion.

Avoid mechanical shocks, drops, collisions, punctures with hard objects and pressure shocks, which may result in battery damage or fire.

It is strictly prohibited to disassemble, modify or damage the battery (such as inserting foreign objects, external pressure, immersion in water or other liquids), which may cause the battery leakage, smoke, release of flammable gases, thermal runaway, fire or explosion.

It is strictly prohibited to contact the battery terminals with other metal objects, which may lead to heat generation or electrolyte leakage.

Warning











When the battery is installed and tested, it shall be equipped with fire fighting facilities, such as fire fighting sand, carbon dioxide fire extinguishers, etc., in accordance with the construction standard specifications. Before putting into operation, it should be ensured that fire-fighting facilities are equipped in accordance with local laws, regulations

and specifications.

Batteries should be installed in areas away from liquids, and are strictly prohibited to be installed under air-conditioning outlets, vents, machine room outlet windows, water pipes and other locations prone to water leakage, in order to prevent liquids from entering the interior of the equipment and causing equipment failures or short circuits.

After the battery is discharged, the battery should be charged in time, otherwise it may cause the battery to be damaged due to over-discharge.

1.6 Important symbols

Symbol	Interpretation	Symbol	Interpretation
	Caution! Danger due to failure to operate as required may result in moderate or minor personal injury, as well as damage to the product!		This equipment must not be disposed of with other household waste and must be taken to an appropriate organisation for recovery and recycling!
	Danger: High voltage hazard!		Recyclable!
	Fireworks are strictly prohibited.		This side is upwards and must not be tilted upside down.
	Do not step on it!		Please read the manual carefully before use!
	The air outlet of the device is hot, be careful when touching it!		Grounding markings.
	Wait 5 minutes after power failure to ensure that the machine is fully discharged before carrying out service operations.		

2 System Introduction

2.1 System Overview

Oasis Flex adopts bracket support fixing solution, which is basic bracket installation and flexible configuration, and can easily meet your different capacity requirements in different scenarios at low cost.

The battery cell specification of Oasis Flex is 3.2V/100Ah, and the PACK specification is 51.2V/5.12kWh. By connecting 5~16 battery cells in series with a main control box for centralised energy management and current input/output, Oasis Flex ensures optimal system stability in indoor environments. Oasis Flex has a built-in BMS with battery cell temperature detection, connector temperature detection, voltage detection and management, and fault and abnormality management and protection.

At the same time, Oasis Flex also has a built-in IoT hardware module, which supports remote operation and maintenance, supports two channels for viewing battery operation information: desktop browser and mobile phone APP. The system application scenarios are shown below:

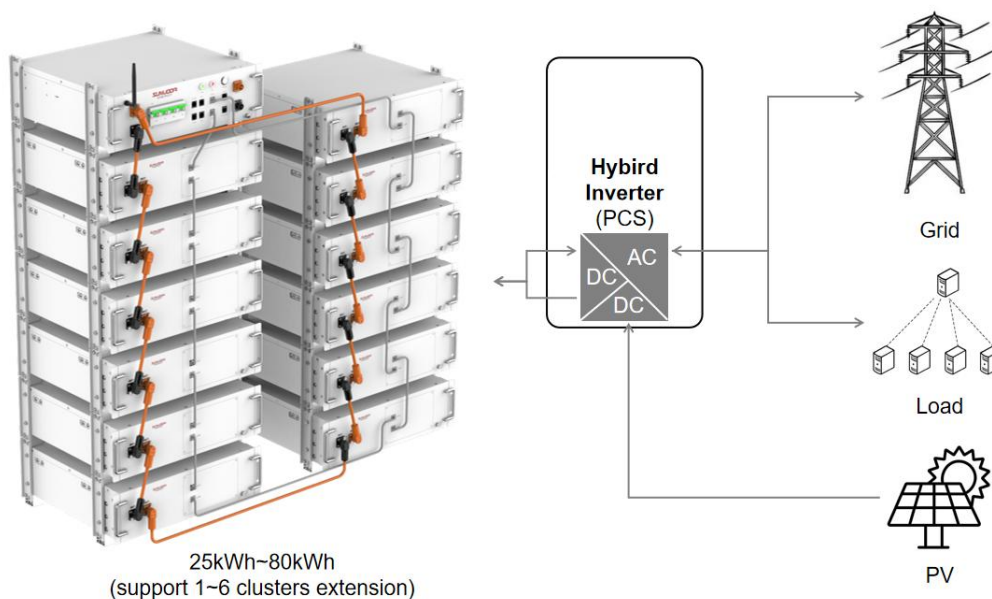

2.2 Module Dimensions

2.2.1 Battery cell

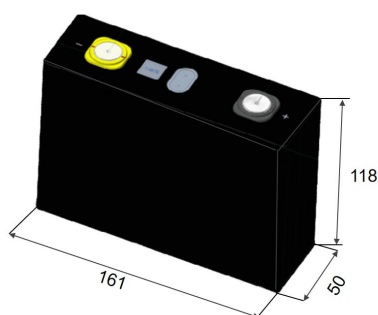

	Widths	Thickness	Height
102Ah Battery cell	161mm	50mm	118mm

2.2.2 Battery box

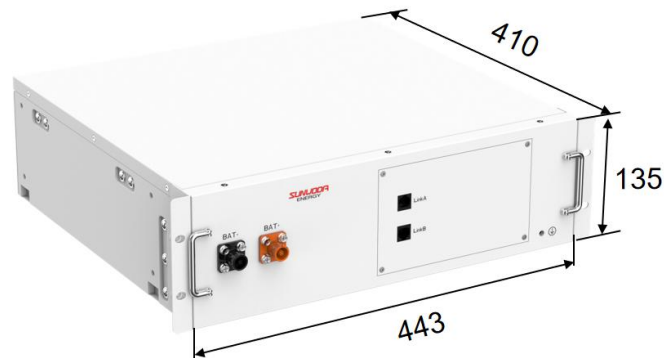

	Widths	Thickness	Height
Battery box	443mm	410mm	135mm

2.2.3 Control box

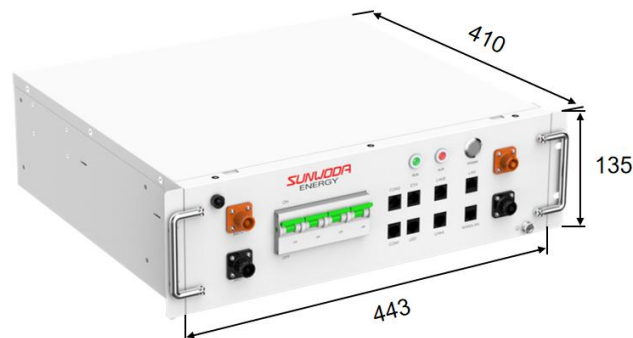

	Widths	Thickness	Height
Control box	443mm	410mm	135mm

2.3 Module and system parameters

2.3.1 Battery cell parameters

Battery cell type	Energetic Square Li-ion battery cell
Battery cell model	SBP-01-1000
Nominal capacity (0.5C)	102Ah
Standard charge/discharge current	0.5C
Maximum continuous charge/discharge current	1C
Charge cut-off voltage	3.65V
Discharge cut-off voltage	T > 0°C 2.5V; T ≤ 0°C 2.0V
Charge temperature range	0~65°C
Discharge temperature range	-30~65°C

Storage temperature	-40~65℃
Optimum operation temperature	15~35℃
AC internal resistance	<0.5m Ω
Weight	2kg

2.3.2 Battery box parameters

Battery box name	B051100S02
Battery cell type	SBP-01-1000
Battery cell grouping method	16S1P
Rated capacity	100Ah
Rated Voltage	51.2V
Operating Voltage Range	44.8~57.6V
Internal Resistance	<30m Ω
Rated charge/discharge current(25℃)	50A
Maximum Continuous Charge/Discharge Current (25℃)	100A
Operating Temperature	Charging: [0~50]℃, Discharging:[-20~55]℃
Working Humidity	10%~95%RH
Cooling method	Natural air-cooled
Protection Grade	IP20
Weight	43.3kg

2.3.3 Control box parameters

Control box model	H1K0100S02-R
Rated Voltage	1000VDC
Rated current	100A
Maximum allowable current	120A,20s
Weight	17kg
Protection grade	IP20

2.3.4 System parameters

(1) 25~40kWh System

System Model	CIESS 25-R-S	CIESS 30-R-S	CIESS 35-R-S	CIESS 40-R-S
System battery cell and PACK specifications				
Battery cell capacity	102Ah,3.2V			

Battery cell quantity /PACK	16S1P			
PACK Capacity	5.2kWh,51.2V			
PACK Quantity	5	6	7	8
PACK Size	443(W)*410(D)*135(H)mm			
PACK Weight	43.3kg			
PACK Protection level	IP20			
System Electrical Specifications				
Voltage range	236~280V	283.2~336V	330.4~392V	377.6~448V
Rated voltage	256V	307.2V	358.4V	409.6V
Rated energy	25kWh	30kWh	35kWh	40kWh
Rated discharge current	50A			
Max. discharge current	100A			
DC side energy efficiency	95%			
Recommended discharge cut-off SOC	10%			
Cycle life	6000 times (25℃,0.5C/0.5C,90%DoD,70%EOL) *			
Protection level	IP20			
Expand ability	Supports 6 clusters in parallel			
Cooling method	Natural Cooling			
Max. altitude	2000m			
Operating temperature requirements	Charging: 0~50℃; Discharging: -20~55℃.			
Operating humidity requirements	10%~95%RH			
Communication protocol type	CAN,RS485,ETH,WIFI			
Basic protection function	Short-circuit protection, over-current protection, over-charge protection, over-discharge protection, over-voltage protection, under-voltage protection, high temperature protection, low temperature protection			
System Physical Specifications				
Dimension,W*D*H,mm	480*410*1040	480*410*1210	1180*410*700	1180*410*870
Weight	248kg	294kg	340kg	386kg
Other				
Product certification	UN38.3, IEC62619, IEC 62477, CE-EMC,CE-RED			
Warranty	5 years*			
Storage temperature	20℃~30℃			

requirements	
Storage humidity	5% RH~80% RH

*For warranty instructions, please refer to the warranty terms.

(2) 45~60kWh System

System Model	CIESS 45-R-S	CIESS 50-R-S	CIESS 55-R-S	CIESS 60-R-S
System battery cell and PACK specifications				
Battery cell capacity	102Ah,3.2V			
Battery cell quantity /PACK	16S1P			
PACK Capacity	5.2kWh,51.2V			
PACK Quantity	9	10	11	12
PACK Size	443(W)*410(D)*135(H)mm			
PACK Weight	43.3kg			
PACK Protection level	IP20			
System electrical specifications				
Voltage range	424.8~504V	472~560V	519.2~616V	566.4~672V
Rated voltage	460.8V	512V	563.2V	614.4V
Rated energy	45kWh	50kWh	55kWh	60kWh
Rated discharge current	50A			
Max. discharge current	100A			
DC side energy efficiency	95%			
Recommended discharge cut-off SOC	10%			
Cycle life	6000 times (25°C,0.5C/0.5C,90%DoD,70%EOL)*			
Protection level	IP20			
Expand ability	Supports 6 clusters in parallel			
Cooling method	Natural Cooling			
Maximum altitude	2000m			
Operating temperature requirements	Charging: 0~50°C; Discharging: -20~55°C.			
Operating humidity requirements	10%~95%RH			
Communication protocol type	CAN,RS485,ETH,WIFI			
Basic protection function	Short-circuit protection, over-current protection, over-charge protection, over-discharge protection, over-voltage protection, under-voltage protection, high temperature protection, low temperature protection			

System physical specifications				
Dimension, W*D*H, mm	1180*410*870	1180*410*1040	1180*410*1040	1180*410*1210
Weight	432kg	478kg	524kg	570kg
Other				
Product certification	UN38.3, IEC62619, IEC 62477, CE-EMC, CE-RED			
Warranty	5 years*			
Storage temperature requirements	20°C ~ 30°C			
Storage humidity	5% RH ~ 80% RH			

*For warranty instructions, please refer to the warranty terms.

(3) 65~80kWh System

System Model	CIESS 65-R-S	CIESS 70-R-S	CIESS 75-R-S	CIESS 80-R-S
System battery cell and PACK specifications				
Battery cell capacity	102Ah, 3.2V			
Battery cell quantity /PACK	16S1P			
PACK Capacity	5.2kWh, 51.2V			
PACK Quantity	13	14	15	16
PACK Size	443(W)*410(D)*135(H)mm			
PACK Weight	43.3kg			
PACK Protection level	IP20			
System electrical specifications				
Voltage range	613.6~728V	660.8~784V	708~840V	755.2~896V
Rated voltage	665.6V	716.8V	768V	819.2V
Rated energy	65kWh	70kWh	75kWh	80kWh
Rated discharge current	50A			
Max. discharge current	100A			
DC side energy efficiency	95%			
Recommended discharge cut-off SOC	10%			
Cycle life	6000 times (25°C, 0.5C/0.5C, 90%DoD, 70%EOL)*			
Protection level	IP20			
Expand ability	Supports 6 clusters in parallel			
Cooling method	Natural Cooling			
Maximum altitude	2000m			
Operating temperature	Charging: 0~50°C; Discharging: -20~55°C.			

requirements				
Operating humidity requirements	10%~95%RH			
Communication protocol type	CAN,RS485,ETH,WIFI			
Basic protection function	Short-circuit protection, over-current protection, over-charge protection, over-discharge protection, over-voltage protection, under-voltage protection, high temperature protection, low temperature protection			
System physical specifications				
Dimension,W*D*H,mm	1880*410*870	1880*410*870	1880*410*1040	1880*410*1040
Weight	616kg	662kg	708kg	754kg
Other				
Product certification	UN38.3, IEC62619, IEC 62477, CE-EMC,CE-RED			
Warranty	5 years*			
Storage temperature requirements	20°C ~30°C			
Storage humidity	5% RH ~80% RH			

*For warranty instructions, please refer to the warranty terms.

3 Mechanical Installation





The product must be installed by specialised personnel in accordance with local standards and regulations and in strict accordance with the installation procedures recommended in the manual.

3.1 Installation Precautions

1	Whether the ambient temperature of the battery is within the specified range: charging at 0~50°C, discharging at -20~55°C.
2	The battery system needs to be installed on a flat and sufficiently load-bearing indoor floor; if the floor has limited flatness and load-bearing performance, it can be filled by means of making a foundation and adding load-bearing plates.
3	Avoid installing equipment in an environment that is close to a high-temperature heat source or a low-temperature cold source.
4	Avoid installing the equipment in the area where the ambient temperature changes too fast and the climate is extreme.
5	Avoid installing the equipment in a strong interference environment.
6	Avoid installing the equipment in sites where children often gather to prevent children from contacting it.
7	Avoid installing the equipment in areas prone to water-logging.
8	Avoid placing flammable, explosive, or corrosive types of objects around the equipment.
9	Make sure a carbon dioxide, Novac 1230 or FM-200 fire extinguisher is available near the equipment. Use the recommended type of fire extinguisher, water or ABC dry powder extinguishers should not be used to extinguish the fire; firefighters must wear protective clothing and self-contained breathing apparatus before operation.
10	The installation location should be well ventilated; installation or operation in a smoky environment is prohibited.
11	Before installation, the battery system needs to be carried to the installation location. To prevent injury to personnel or damage to the equipment during the process, please pay attention to the following matters: <ul style="list-style-type: none">① According to the weight of the equipment, estimate the number of manpower and the required handling tools, so as to prevent the equipment from exceeding the range of individually transportable weight and causing damage.② Ensure that the equipment is balanced during transportation and avoid falling.
12	Avoid installing the equipment in extreme environments such as sun, rain, or snow cover.

13	Do not tilt or place the product on its side.
----	---

3.2 Accessories Preparation

Name	Picture	Amount	Name	Picture	Amount
M5*10 screws		24pcs/box	Terminal Resistor		1pcs/system
Aluminium bracket		4pcs/box	Sheet metal bracket		4pcs/box

3.3 Installation Procedure

Warning Notes:

1	Select an indoor site, before installation, make sure the floor is level, floor loading $\geq 1500\text{kg/m}^2$, horizontal spacing between adjacent battery packs $\geq 200\text{mm}$.
2	Installation must be completed by professional personnel in the following steps.
3	Use the products and accessories shipped by our company, do not mix different brands of products.

3.2.1 Assembly of basic brackets

(1) Take 1 sheet metal bracket and 1 aluminium bracket and assemble them into 1 set of basic brackets (Fig. 3.1) with 2 M5*12 screws as shown in the diagram.

(2) Each box corresponds to 4 sets of basic brackets (1 set). The number of sets of basic brackets required for different models is as follows (Table 3.1):

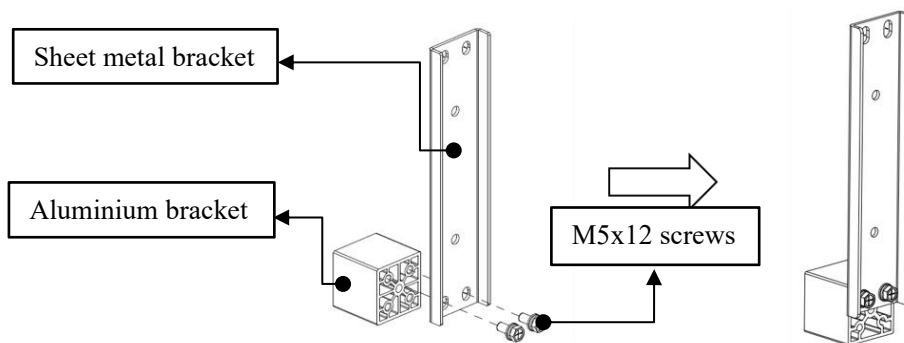

Fig.3.1 Assembly the basic bracket

Table 3.1 Number of basic brackets required for each system model

System Model	Basic Bracket Numbers	System Model	Basic Bracket Numbers
CIESS 25 R-S	6 groups:24 sets	CIESS 30 R-S	7 组-28sets
CIESS 35 R-S	8groups:32sets	CIESS 40 R-S	9 组-36sets
CIESS 45 R-S	10groups:40sets	CIESS 50 R-S	11groups:44sets
CIESS 55 R-S	12groups:48sets	CIESS 60 R-S	13groups:52sets

CISS 65 R-S	14groups:56sets	CISS 70 R-S	15groups:60sets
CISS 75 R-S	16groups:64sets	CISS 80 R-S	17groups:68sets

Notes: There are 4 sets in each group, and the number needed for each box (either the control box or the battery box) is one group.

3.2.2 Assemble basic bracket to box

(1) Take the above assembled basic bracket and fix it to the side of the box with 2 M5*12 screws.

(2) Assemble 4 sets of basic brackets to one box, which will consume a total of 8 screws for one box (Fig.3.2, 3.3).

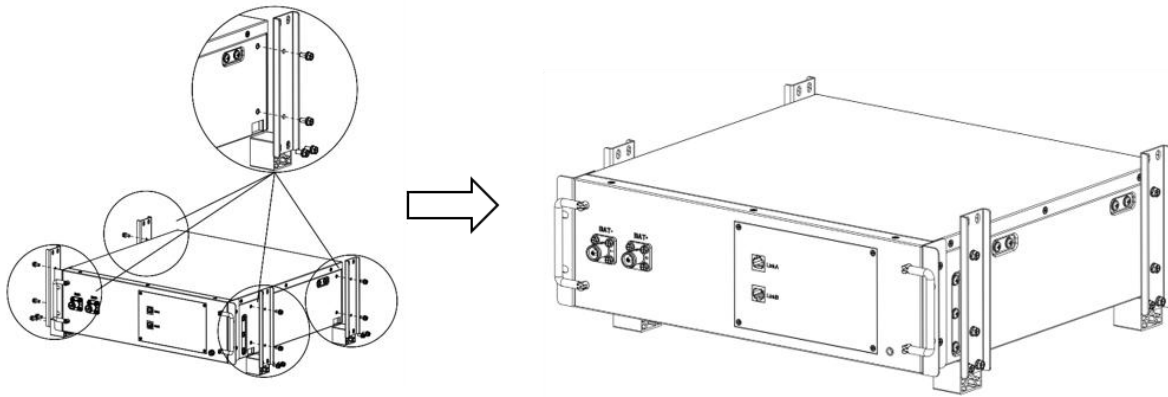

Figure 3.2 Assemble the basic bracket to the battery box

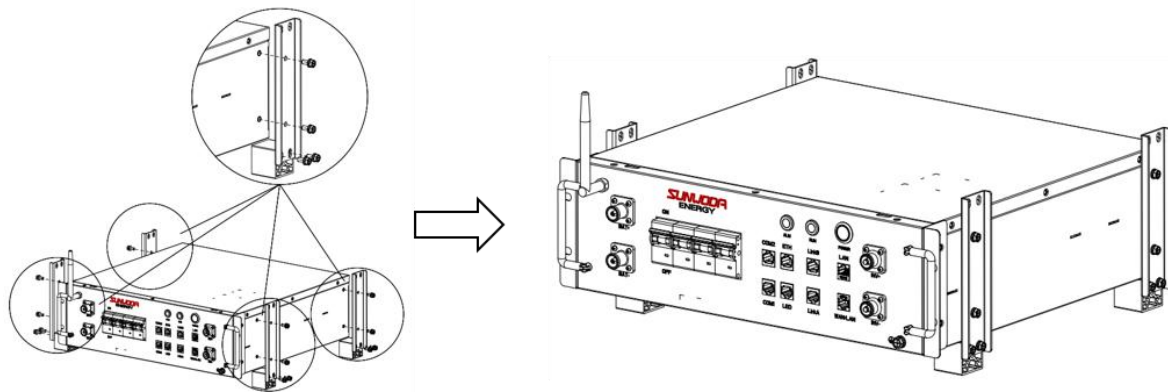

Figure 3.3 Assemble the basic bracket to the control box

3.2.3 Stack the boxes

- (1) Select a flat indoor floor and stack the boxes in rows, starting with the battery box;
- (2) Be sure to fasten one box with 8 (2 x 4) M5*12 screws before starting the next box. At the end of stacking, the control box is always at the top of the column (Fig.3.4,3.5).
- (3) Always refer to the stacking method provided in this manual for stacking.

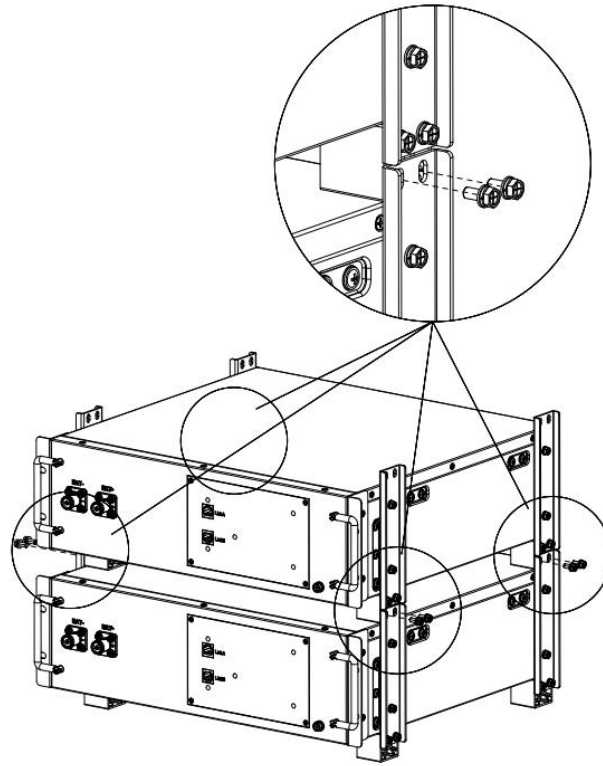
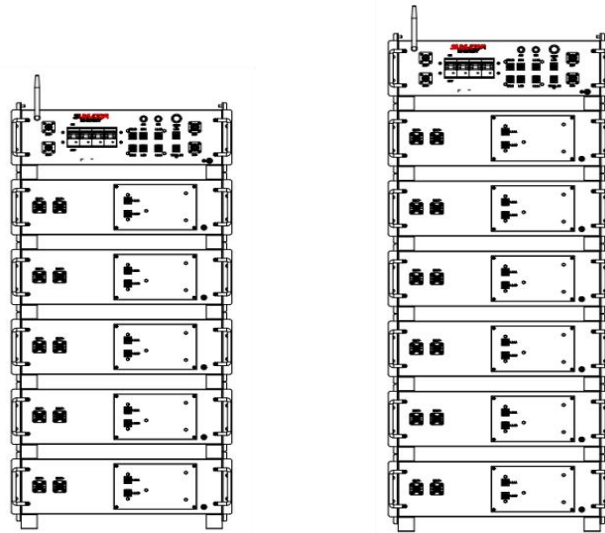

Figure 3.4 Fasten the two boxes



CIESS 25-R-S

CIESS 30-R-S

CIESS 25~30-R-S

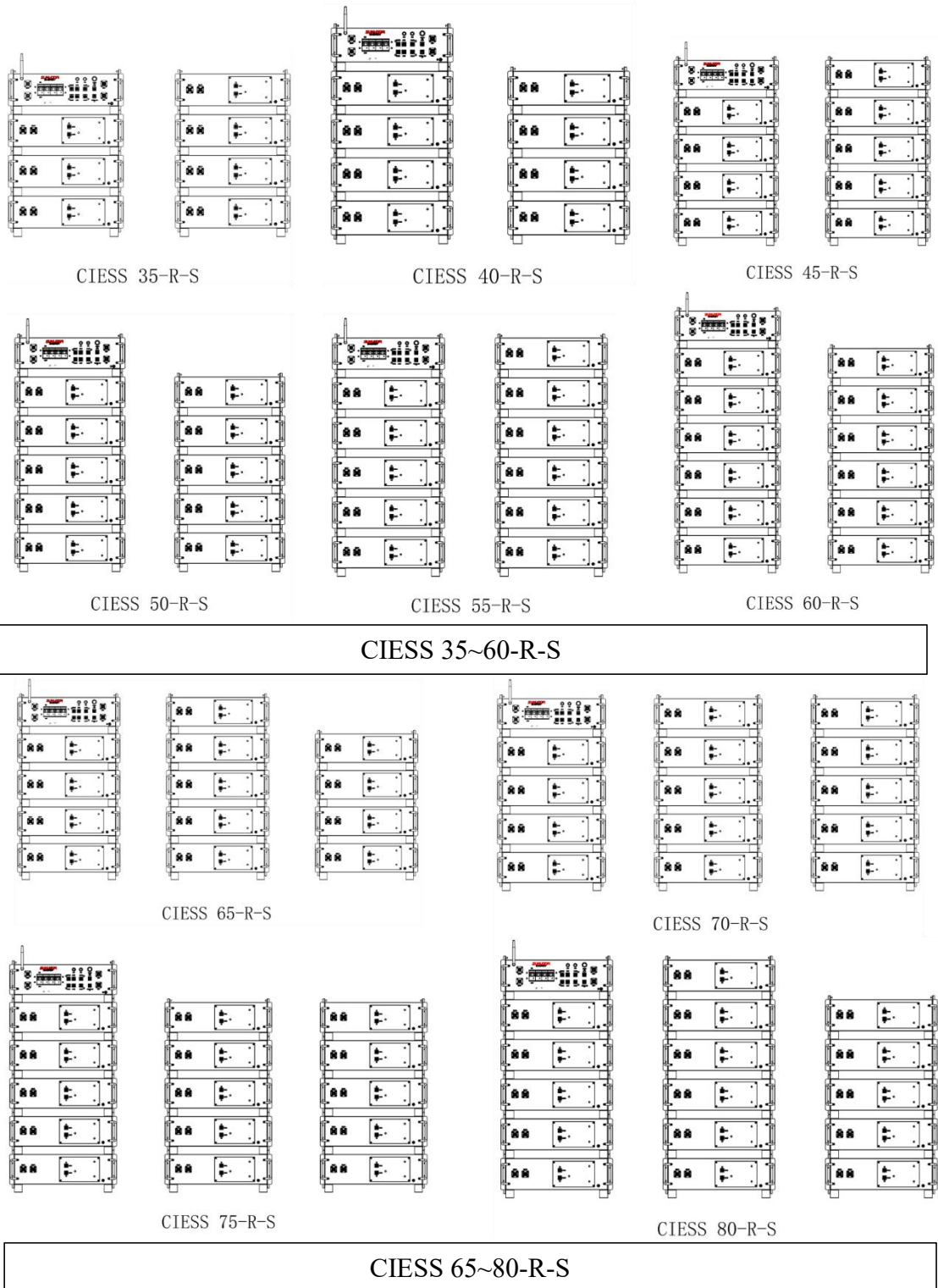

Figure 3.5 Stacking method for each model

4 Electrical connection







Warning Notes:

1	Before connecting the cables, always ensure that all switches remain disconnected and all equipment is switched off or powered off.
2	Wiring must be completed by a professional in the following steps in sequence.
3	Use the cable equipment provided by us or the required wiring harness type, do not use wires arbitrarily.

4.1 Cable Introduction

4.1.1 Ground cables

The list of wiring harnesses corresponding to each system model is as follows:









System Model	Grounding Harness	Material No.	Picture	Length
Grounding cable from control box to battery box:				
CISS 25~80-R-S	A Ground cable	5619100041311		0.18m
Grounding cable from battery box to battery box:				
CISS 25~80-R-S	A Ground cable	5619100041311		0.18m
CISS 35~80-R-S	B Ground cable	5619100061411		1.5m
CISS 65~80-R-S	C Ground cable	5619100062081		2.8m
Cable from control box of battery system to other grounding points such as inverter:				
CISS 25~80-R-S	D Ground cable*	5619100060311		5m

Note: “*” indicates that this harness is used universally in parallel mode.

4.1.2 Power cables

The list of wiring harness corresponding to each system model is as follows:









System Model	Power Harness	Material No.	Picture	Length
Battery box to battery box power harness:				
CISS 25~80-R-S	A Power cable	5619100059301		0.19m

CISS 35~80-R-S	B Power cable	5619100059321		0.9m
Negative power harness from battery box to control box:				
CISS 25~80-R-S	C Power cable	5619100059311		0.2m
Positive power harness from battery box to control box:				
CISS 25-R-S	D Power cable	5619100061311		1.18m
CISS 30-R-S	E Power cable	5619100061391		1.36m
CISS 35~60-R-S	F Power cable	5619100059471		1.01m
CISS 65/70/75/80-R-S	G Power cable	5619100062001		3m
Positive power harness from control box to inverter/ combiner box:				
CISS 25~30-R-S	H Power cable	5619100065041		3.5m(3AWG +8AWG)
CISS 35~80-R-S		5619100065021		3.5m(3AWG +6AWG)
Negative power harness from control box to inverter/cominer box:				
CISS 25~30-R-S	I Power cable	5619100065051		3.5m(3AWG +8AWG)

CISS 35~80-R-S		5619100065031		3.5m(3AWG +6AWG)
-------------------	--	---------------	--	---------------------

4.1.3 Communication cables

The list of wiring harnesses corresponding to each system model is as follows:

System Model	Communication Harness	Material No.	Picture	Length
Battery box to battery box Link port communication harness:				
CISS 25~80-R-S	A Communication cable	5619100059331		0.31m
CISS 35~80-R-S	B Communication cable	5619100059361		0.9m
Control box to battery box Link port communication harness:				
CISS 25~80-R-S	A Communication cable	5619100059331		0.31m
Battery box to control box Link port communication harness:				
CISS 25-R-S	C Communication cable	5619100061281		1.34m
CISS 30-R-S	D Communication cable	5619100061401		1.52m
CISS 35~60-R-S	E Communication cable	5619100059351		0.85m
CISS 65~80-R-S	F Communication cable	5619100062021		3m
Control box to control box/inverter COM port communication harness:				
CISS 25~80-R-S	G Communication cable *	5619100061321		5m
LAN port communication harness:				

CISS 25~80-R-S	LAN Communication cable	5619100062991		2m
-------------------	-------------------------------	---------------	--	----

Note: “*” indicates that this harness is used universally in parallel mode.

4.2 Ground connection

4.2.1 Connect the A ground cable

Use the A ground cable (5619100041311) to connect the ground protection points of the two neighbouring battery boxes. This type of cable is also used for the ground point connection from battery box to control box (Fig. 4.1).

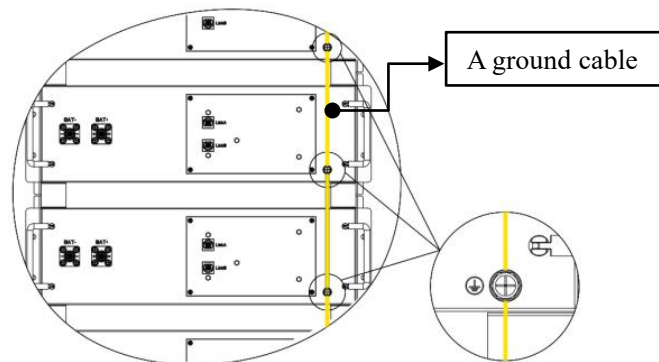

Fig. 4.1 Earth point connection of two adjacent battery boxes in the same row

4.2.2 Connect B and C ground cables

If a single machine has multiple columns, the ground protection points from the first to second columns are connected using the B ground cable (5619100061411), and the ground protection points from the second to third columns (if equipped) are connected using the C ground cable (5619100062081). See the following diagram for wiring locations (Fig. 4.2a,b):

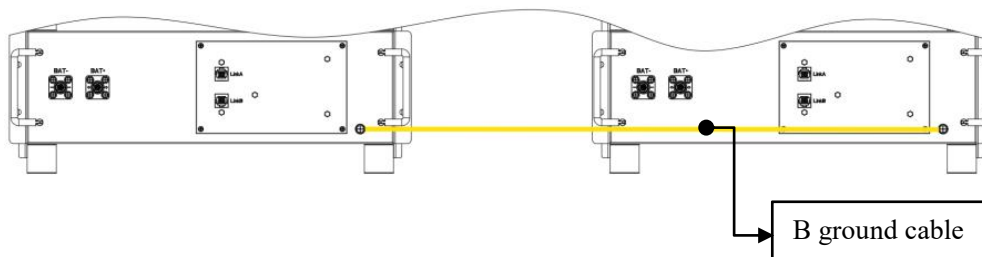

Figure 4.2a Connect the ground point from the first column to the second column

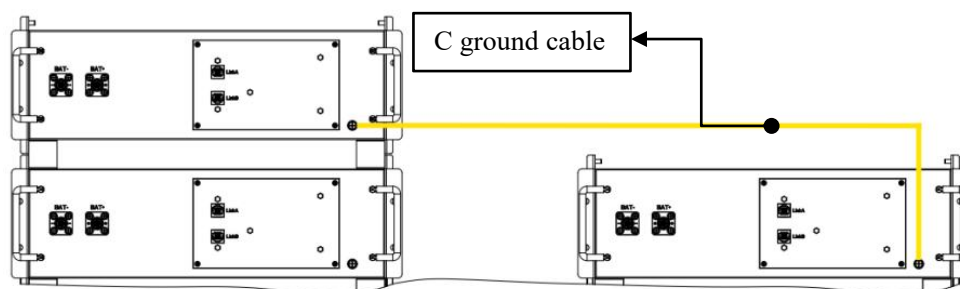

Figure 4.2b Connect the ground point from the second column to the third column

4.2.3 Connect the D ground cable

Use the D ground cable (5619100060311) to connect the battery system to other external grounding points such as the inverter (Fig. 4.3).

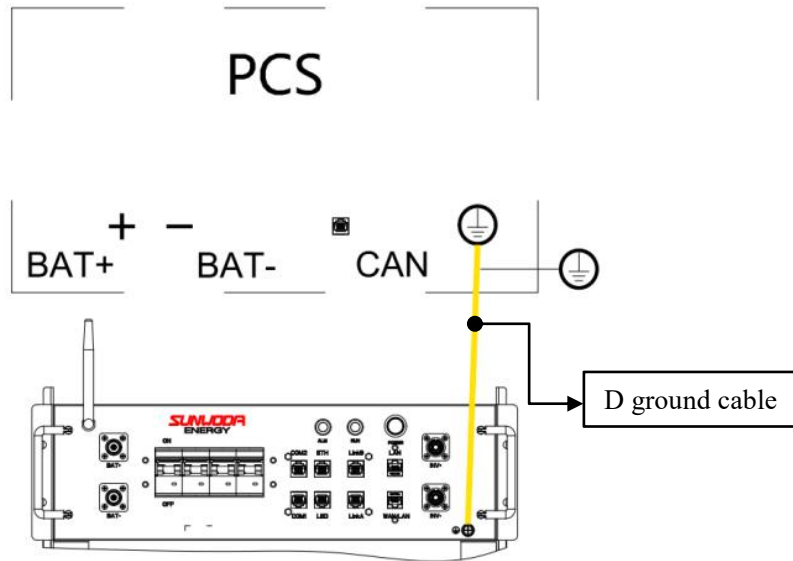
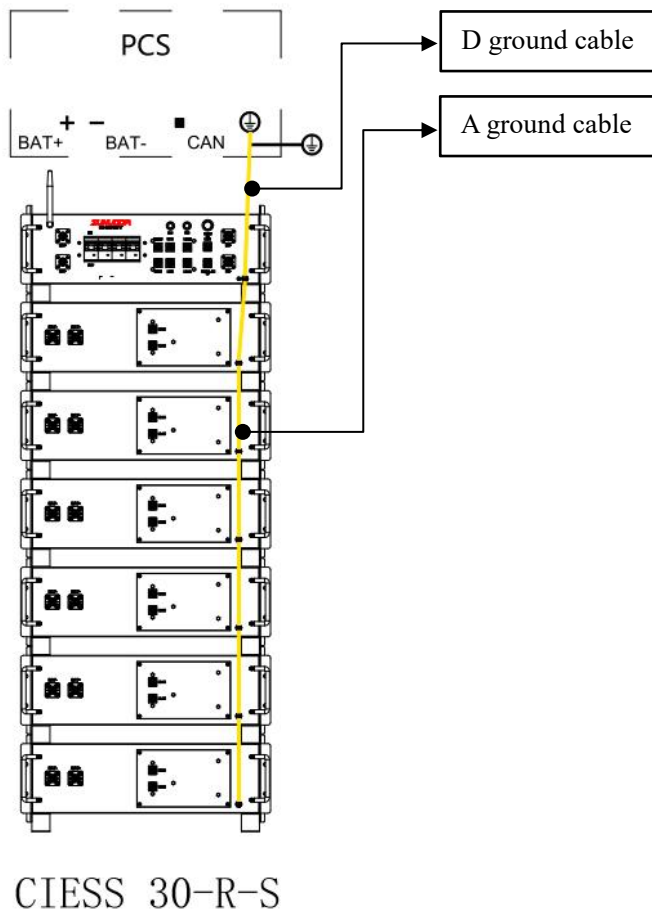
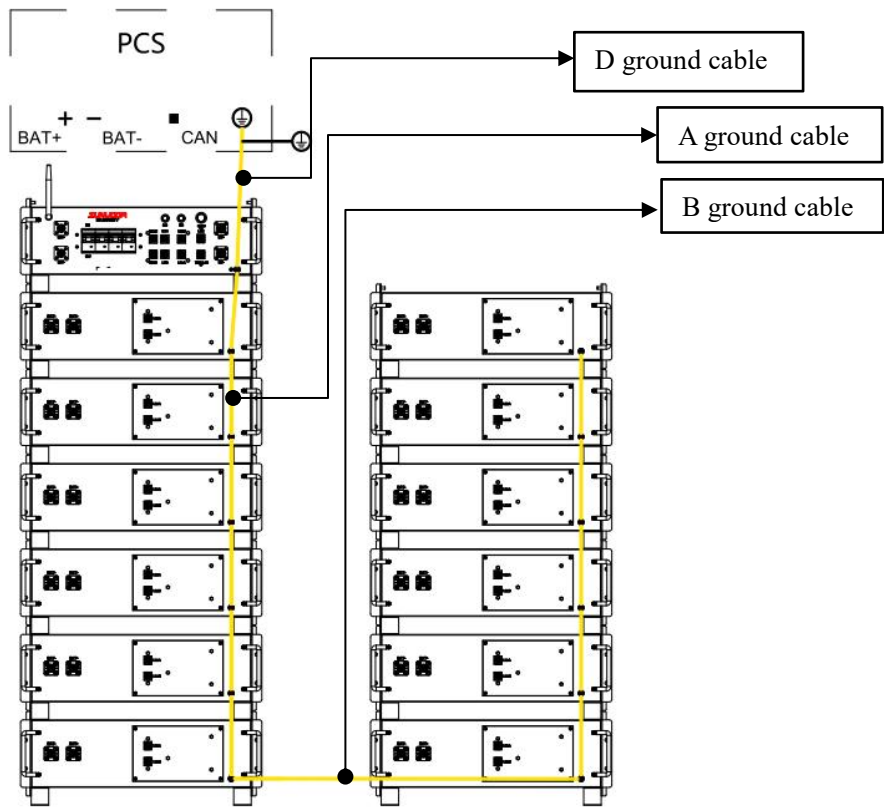

Figure 4.3 Connect grounding point on control box to inverter or other external grounding point

4.2.4 Complete schematic of ground cable connection

Note: Take connection on CIESS 30/60/80-R-S system as the example.





CISS 60-R-S

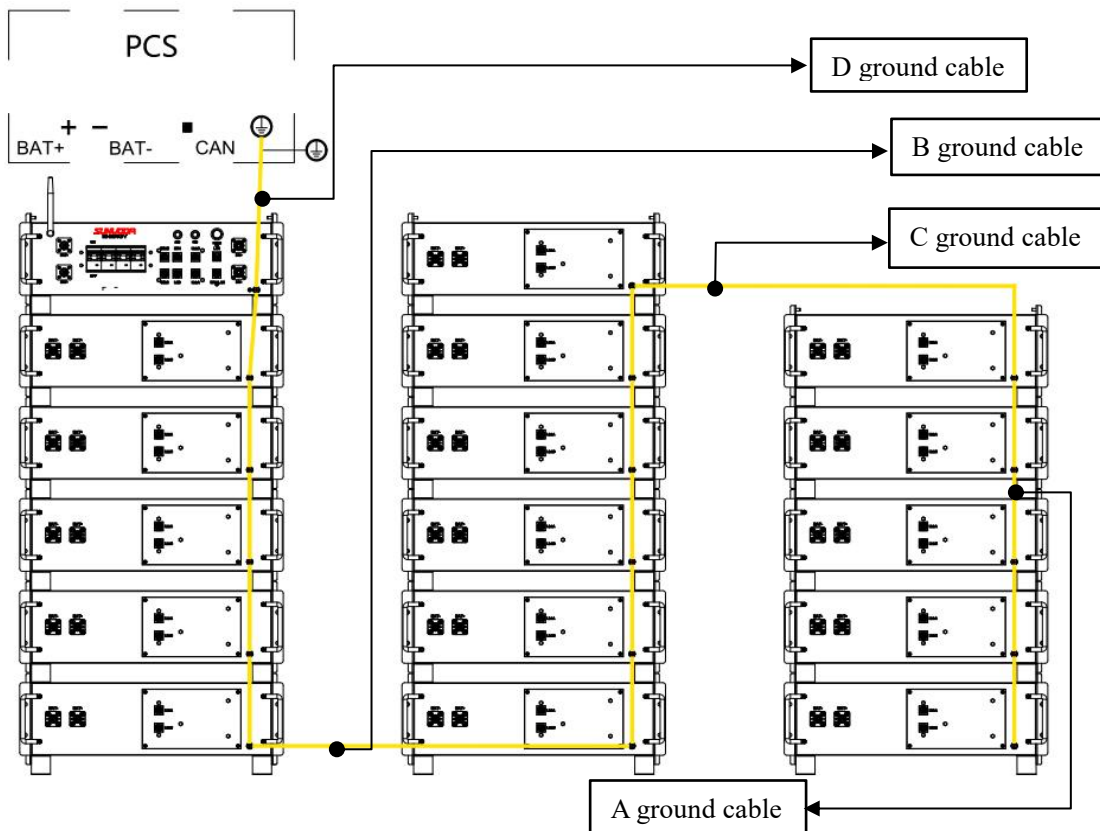

CISS 80-R-S

Fig. 4.4

4.3 Power cable connection

4.3.1 Connector structure and usage of power cable

When connecting the power cable to the unit, press down the connector until a “click” sound is heard.

Note:

When unplugging the power cable from the unit, press and hold the unlock button on the connector (red component in Fig. 4.5).

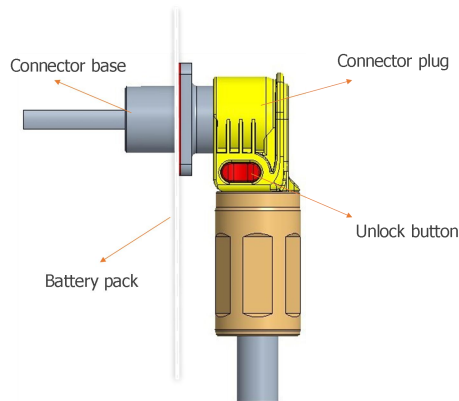

Fig. 4.5

4.3.2 Connect power cables from battery box to battery box

(1) Take one power cable A (5619100059301) and connect the cable from “Bat+” terminal of the first battery box which is under the control box to the “Bat-” terminal of the next battery box without mistakes (Fig. 4.6).

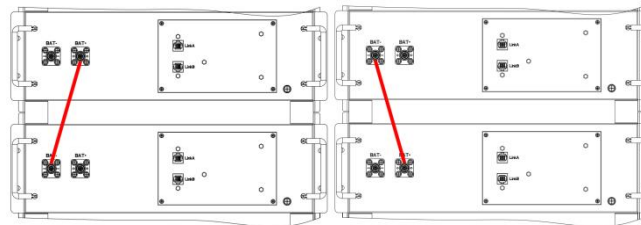
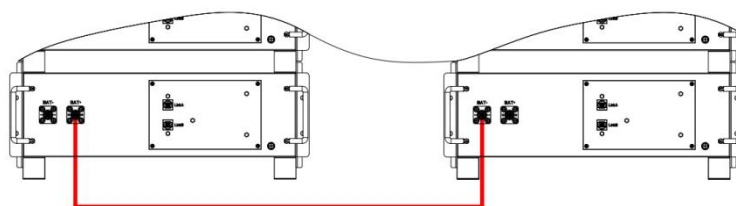

Fig.4.6 Connection power cable A

(2) Repeat step (1) to connect all ‘Bat+’ and ‘Bat-’ terminals on the remaining battery boxes in series.

(3) In the case of a single machine with multiple rows, the positive and negative terminals of the two rows of battery boxes are connected in series using power cable B (5619100059321), see Fig. 4.7 for specific wiring.



4.7a. Connection of Power cable B for columns I-II

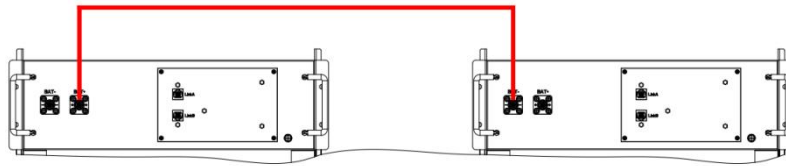

4.7b. Connect power cable B for columns II-III (if equipped)

(4) The types of power cable involved in different system models are shown in table 4.1.

Table 4.1

System model	Power cable involved	Material No.	Length	Amount
CIESS 25~80-R-S	A Power cable	5619100059301	0.19m	1pcs/PACK
CIESS 35~80-R-S	B Power cable	5619100059321	0.9m	1pcs/column

4.3.3 Connect power cable from control box to battery box

(1) Connect the negative power cable:

Take the power cable C (5619100059311), and connect it from control box “Bat-” terminal to battery box “Bat-” terminal. See the diagram below (Fig. 4.8).

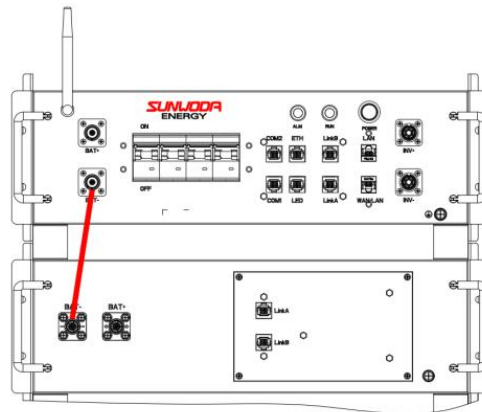

Fig. 4.8 Connect negative power cable from control box to battery box

(2) Connect the positive power cable:

Use D/E/F/G power cable to wire from “Bat +” terminal of the last battery box to “Bat +” terminal of the control box. Different product models correspond to different cable types (Table 4.2); see Fig. 4.9 for wiring method of different product models.

Table 4.2 Battery Box to Control Box Positive Power Cable Types

System Model	Positive Power Cable	Material No.	Length	Qty.
CIESS 25-R-S	D Power cable	5619100061311	1.18m	1pcs/1control box
CIESS 30-R-S	E Power cable	5619100061391	1.36m	1pcs/1control box
CIESS 35~60-R-S	F Power cable	5619100059471	1.01m	1pcs/1control box
CIESS 65~80-R-S	G Power cable	5619100062001	3m	1pcs/1control box

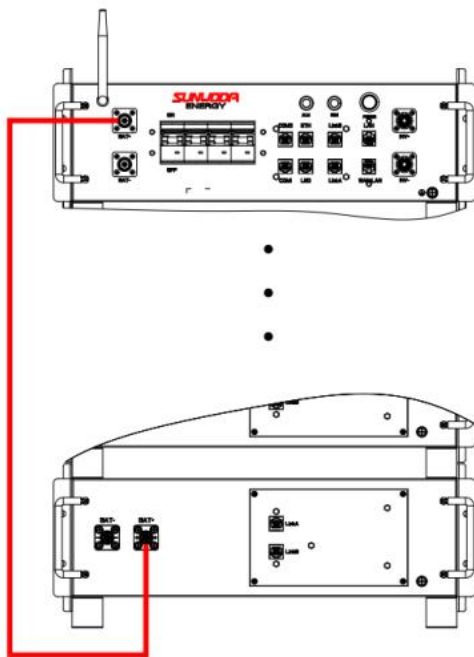

Fig. 4.9a D/E Power cable connection
Applicable models: CIESS 25/30-R-S

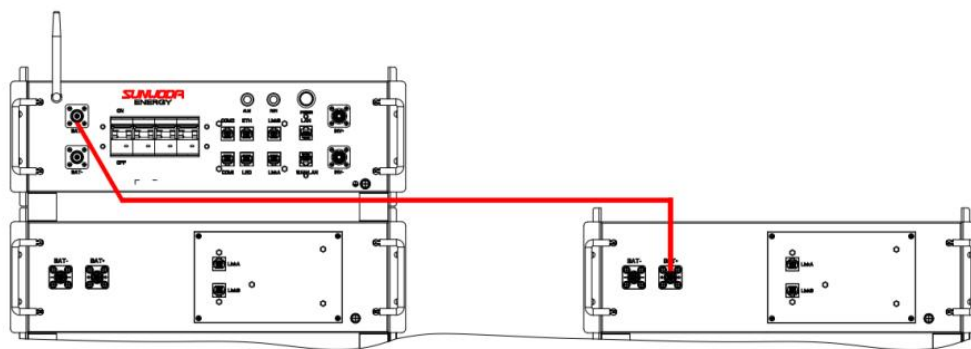

Fig.4.9b F Power cable connection
Applicable models: CIESS 35~60-R-S

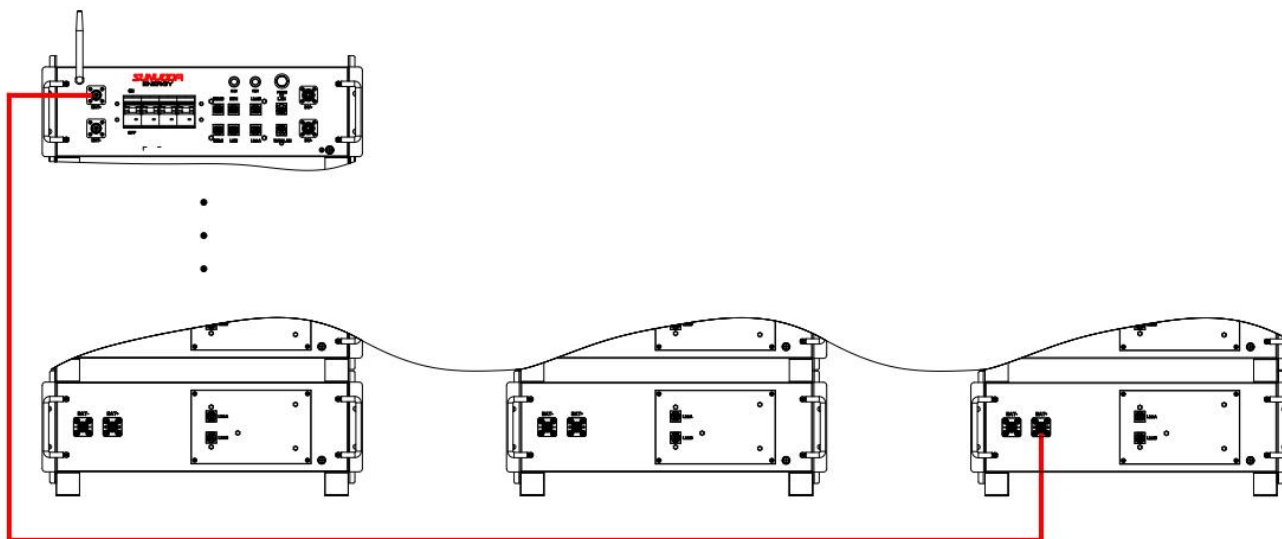

Fig. 4.10c G Power cable connection

4.3.4 Connect the power cable from control box to inverter

The connection method for power cable from control box to inverter is shown below (Fig. 4.11):

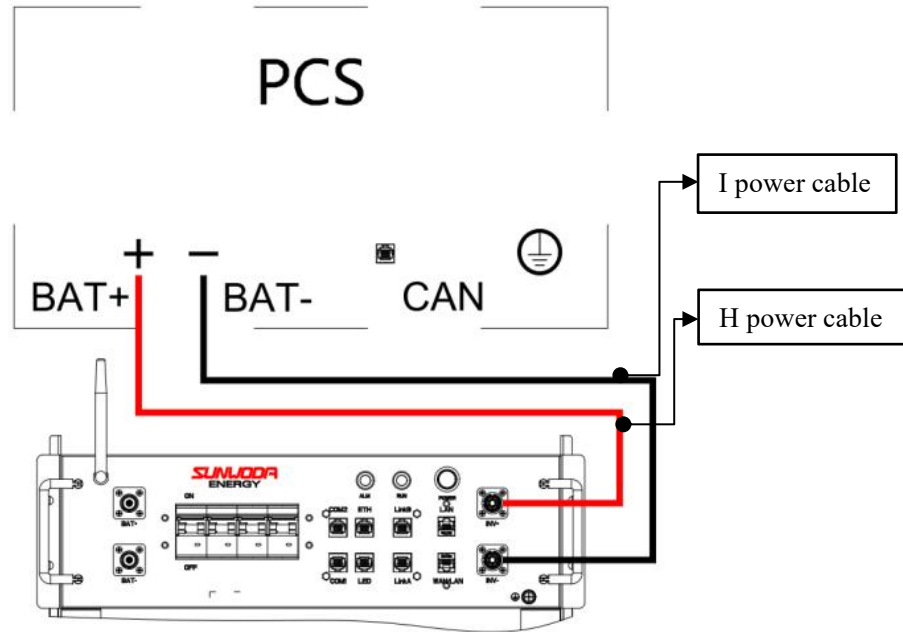

Fig. 4.11 Power cable connection from control box to inverter

Notes:

- ① The H and I power cables corresponding to different system are different, see Table 4.3.
- ② The power cable to inverter is a splicing design, a 3.2m cable is spliced with two 0.3m cables(Fig. 4.12), please cut or choose one of them to connect according to the wiring requirement of the inverter side.

Table 4.3 HI cable specifications for different system models

	CIESS 25/30 -R-S	CIESS 35~80 -R-S
I Power cable	3AWG+8AWG~5619100065051	3AWG+6AWG~5619100065031
H Power cable	3AWG+8AWG~5619100065041	3AWG+6AWG~5619100065021

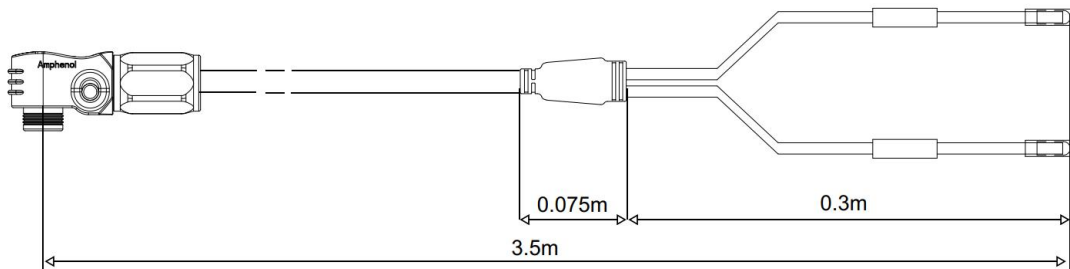

Fig. 4.12a HI power line to inverter for CIESS 25/30 -R-S

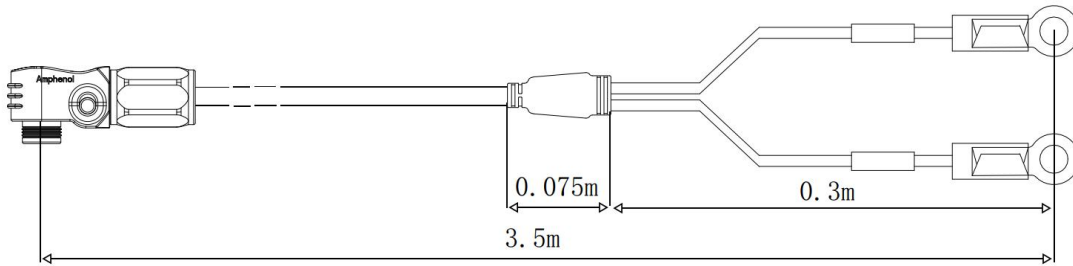
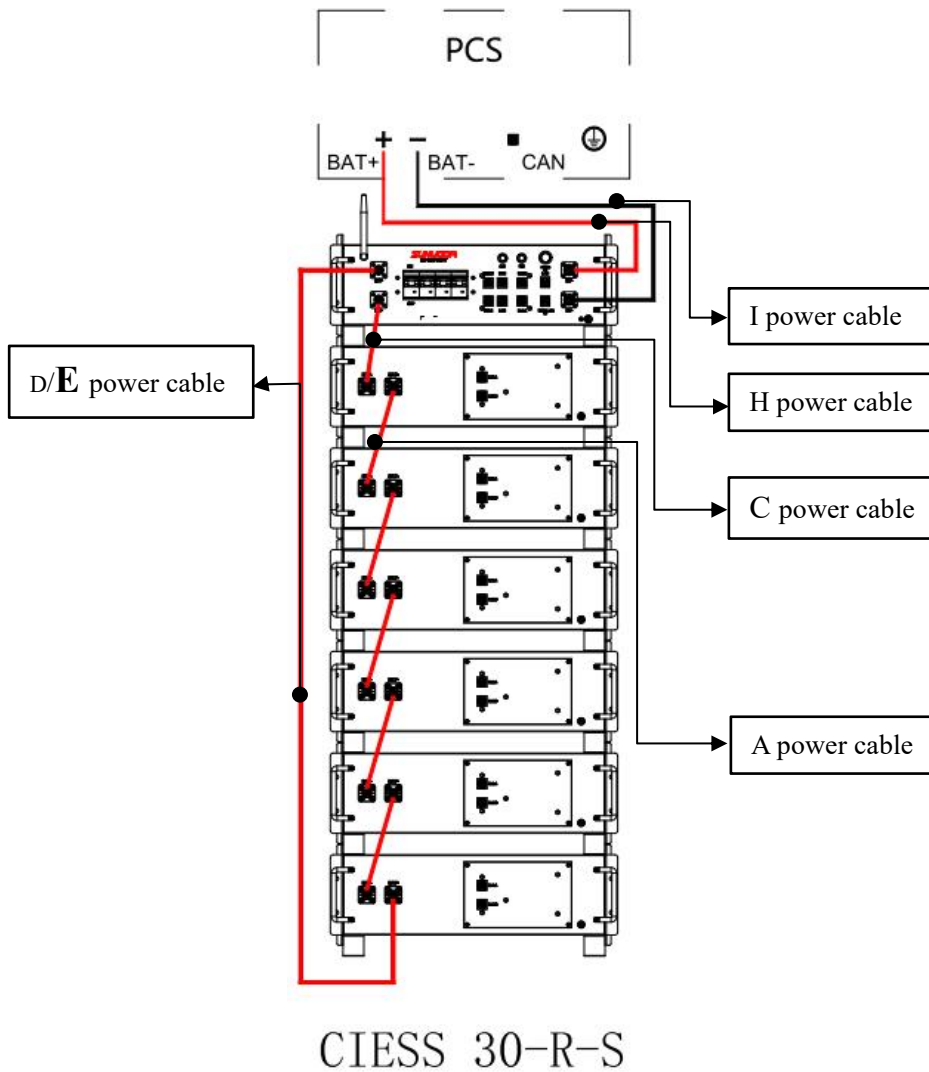
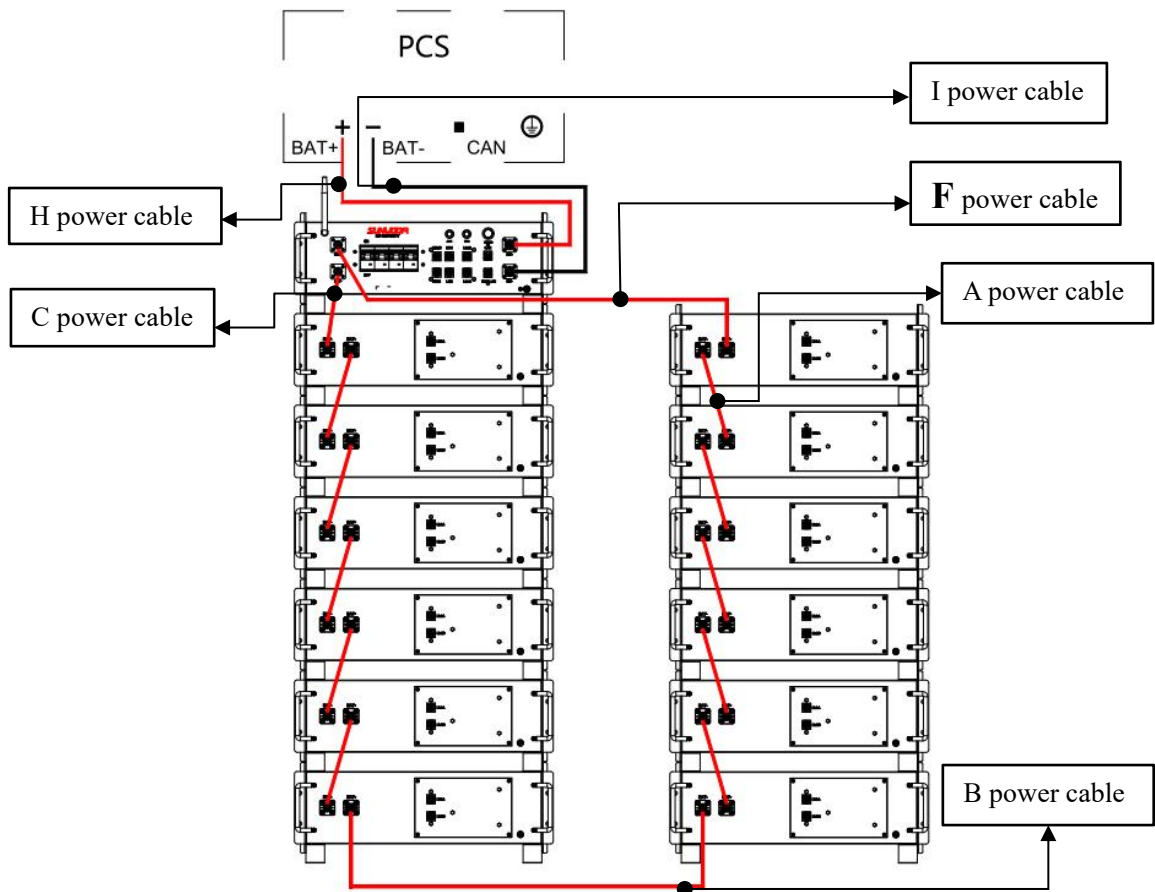

Fig. 4.12b HM power line to inverter for CIESS 35~80 -R-S

4.3.5 Complete schematic of power cable connection

Note: Take connection on CIESS 30/60/80-R-S system as the example.





CIESS 60-R-S

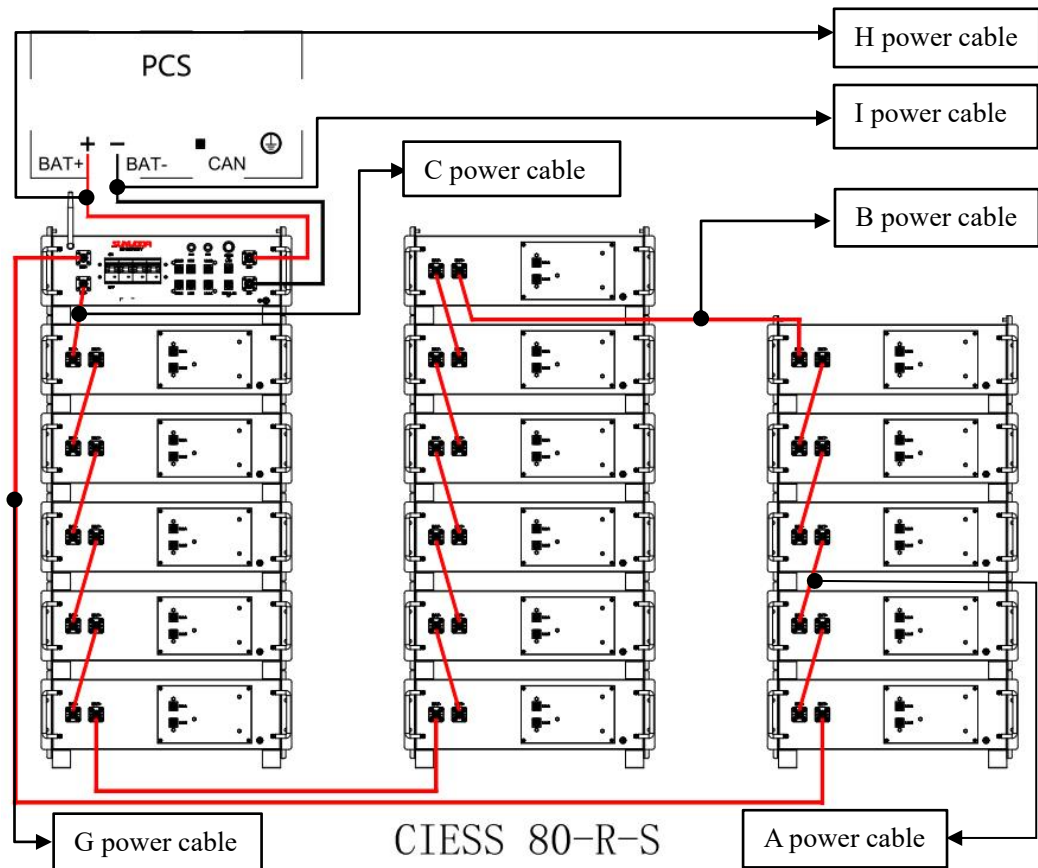

CIESS 80-R-S

Fig. 4.13

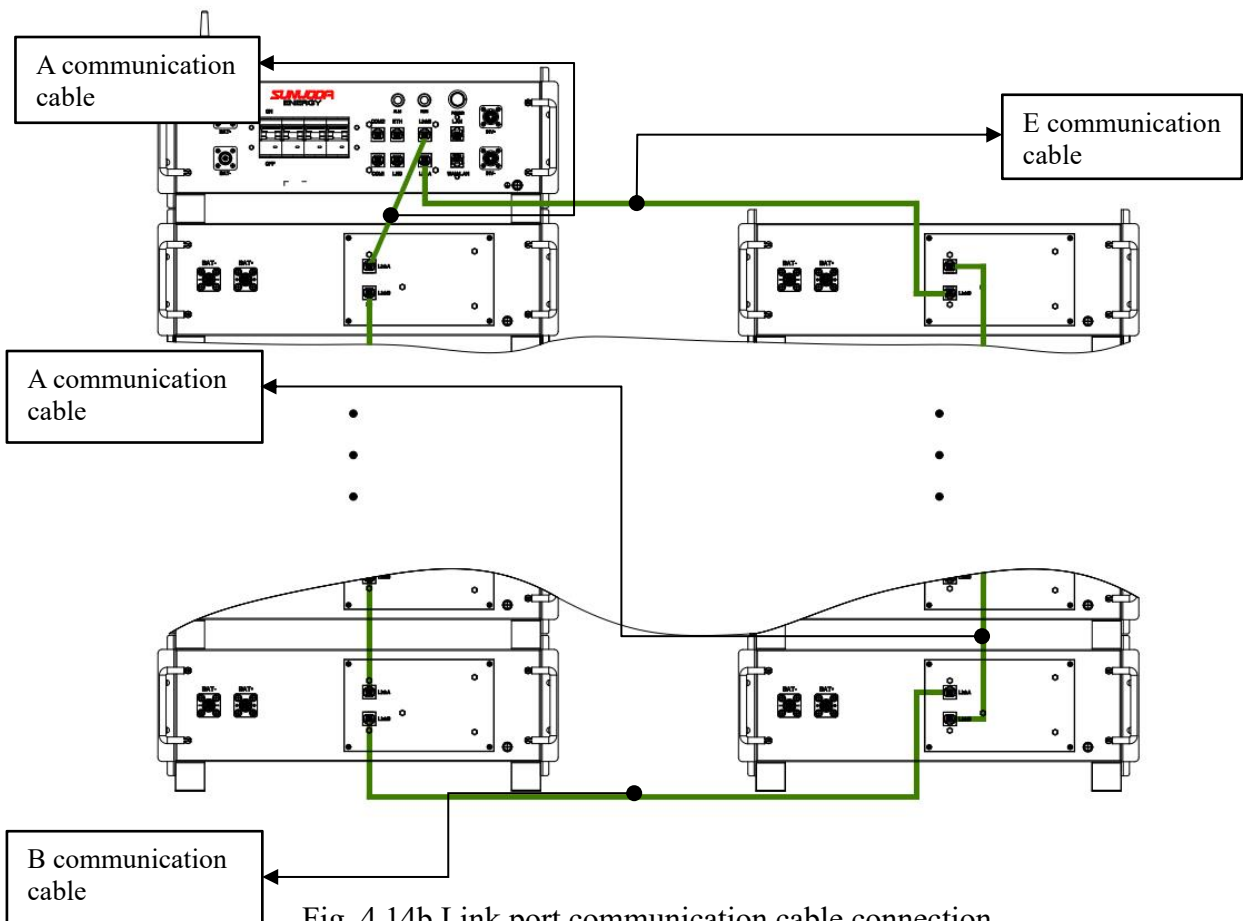

Fig. 4.14b Link port communication cable connection

Applicable models: CIESS 35~60-R-S

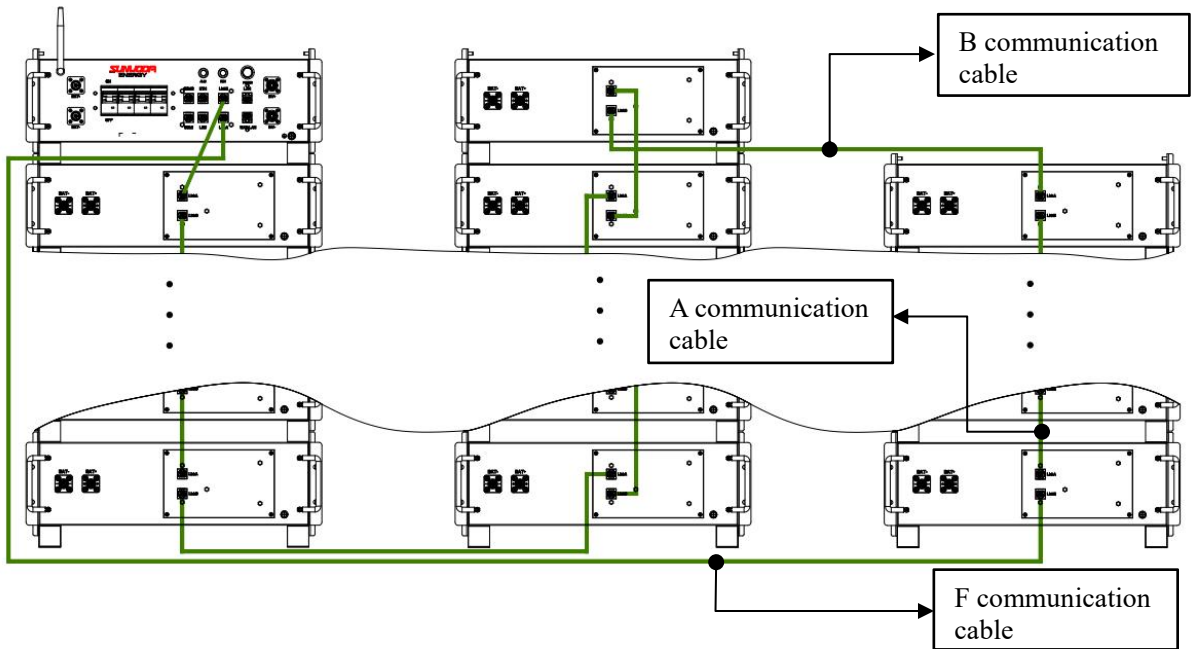

Fig. 4.14c Link port communication cable connection

Applicable models: CIESS 65~80-R-S

Table 4.4 Battery Box to Control Box Link Port communication cable type

System Model	Cable	Material No.	Length	Quantity
CIESS 25 R-S	C communication cable	5619100061281	1.34m	1pcs/control box

CISS 30 R-S	D communication cable	5619100061401	1.52m	1pcs/control box
CISS 35~60 R-S	E communication cable	5619100059351	0.85m	1pcs/control box
CISS 65~80 R-S	F communication cable	5619100062021	3m	1pcs/control box

4.4.2 COM port communication cable connection

Insert the terminating resistor into COM 1 port of the control box, and use the G communication cable (5619100061321) to connect the COM2 of control box to the CAN/BMS communication port of inverter, as shown in the fig. 4.15.

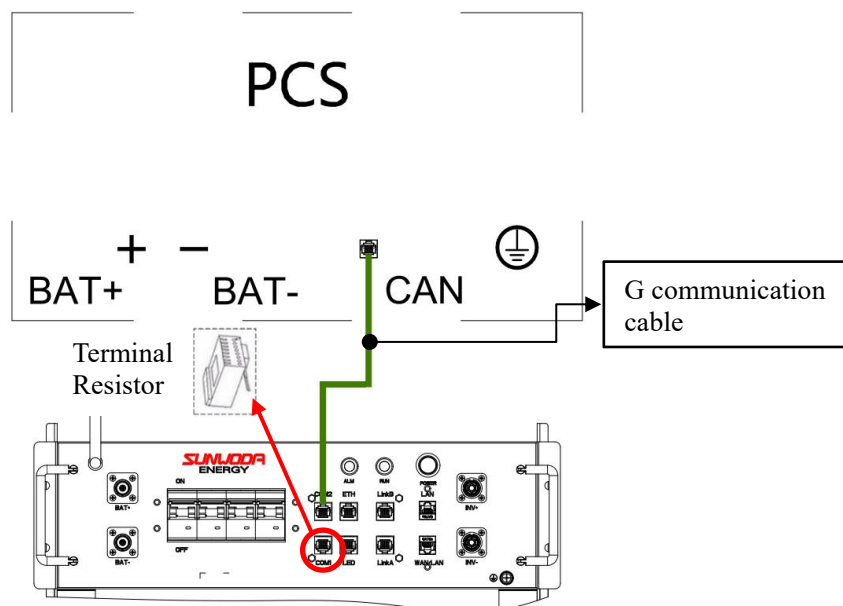

Fig. 4.15 COM port communication cable connection

4.4.3 Lan & WAN port communication cable connection

The LAN and WAN ports on the right side of control box are the communication ports of battery system data module. The LAN port is connected to the PC for local data monitoring and debugging of distribution network, and the WAN port is connected to the router (Fig. 4.16). When the equipment is acquired, please make sure to connect the WAN port on control box with the on-site router to achieve cloud data monitoring.

Note:

- ① It is also possible to enter the network through wireless, see the operation guide of the cloud platform for the details.
- ② The WAN communication cable needs to be provided by yourself, and the LAN communication cable (5619100062991) is included in the shipping list.

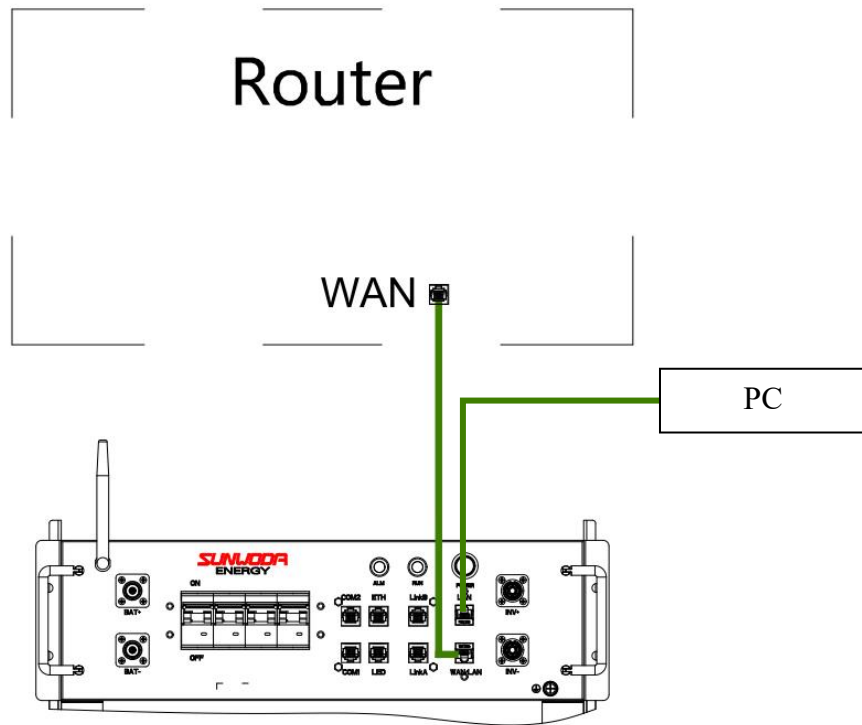
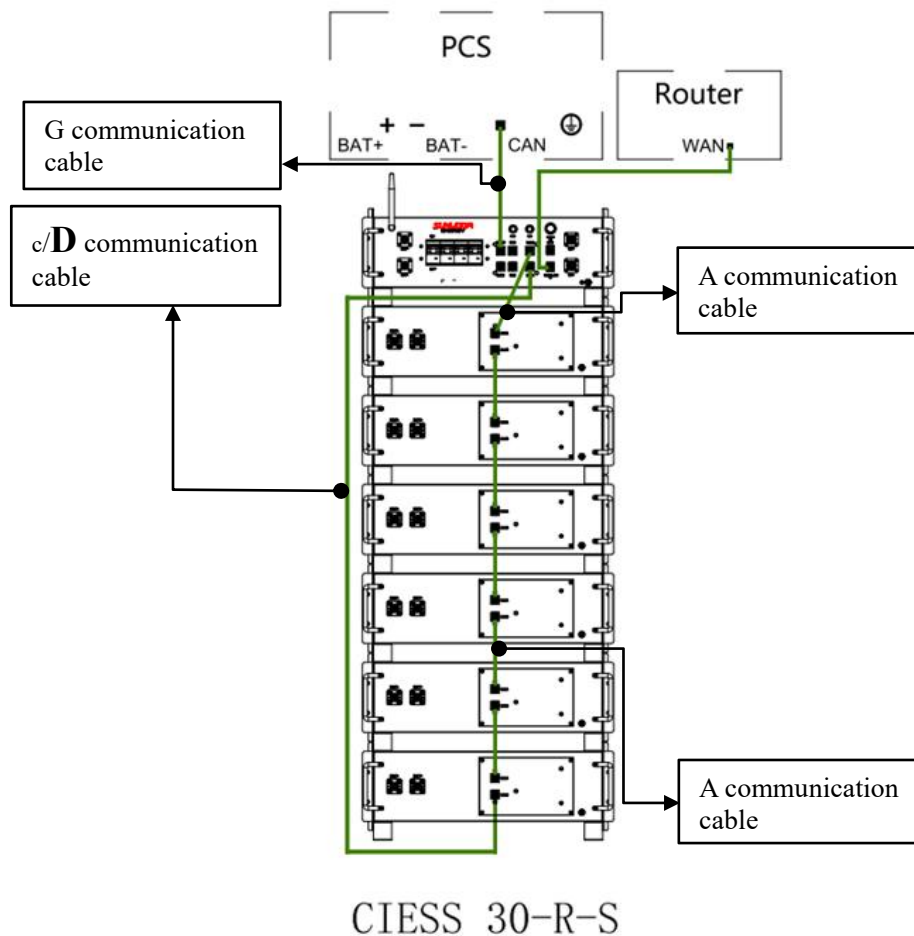

Fig. 4.16 Connect LAN & WAN port communication cable

4.4.4 Complete diagram of communication cable connection

Note: Take connection on CIESS 30/60/80-R-S system as the example.



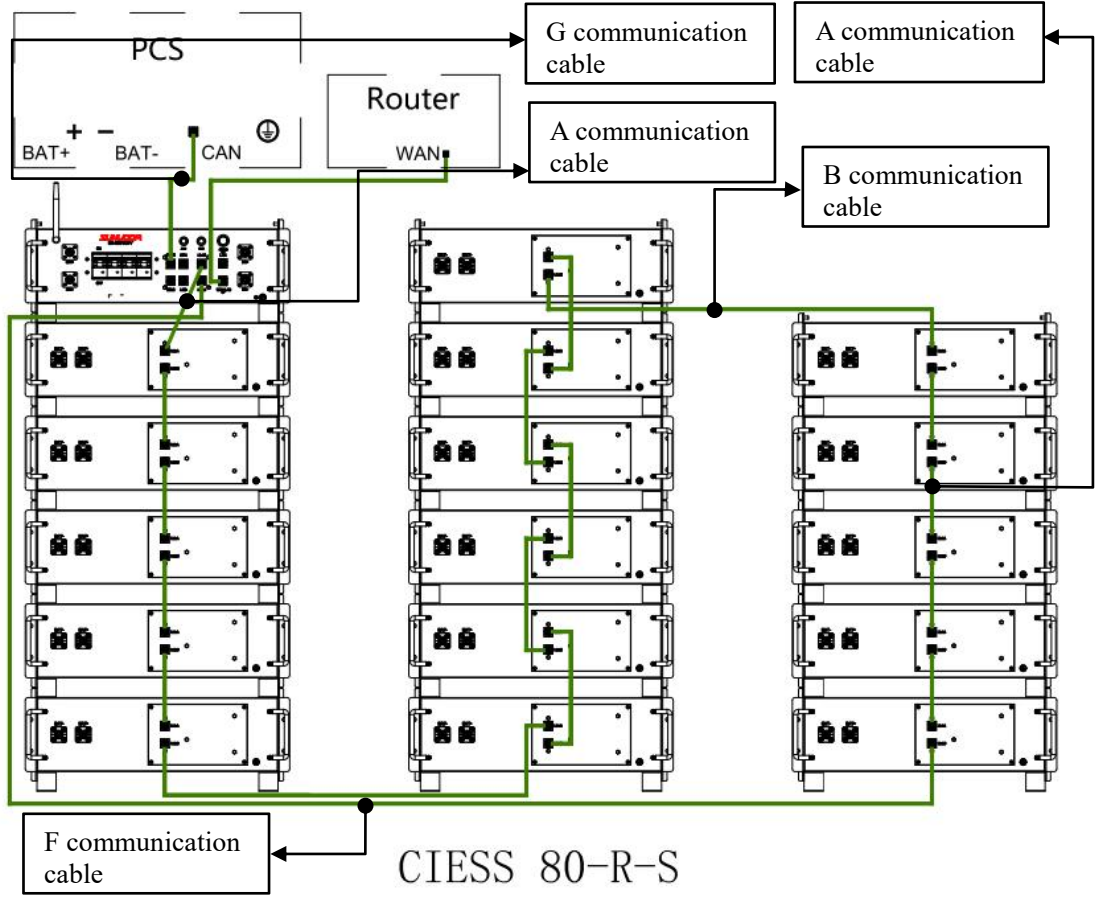
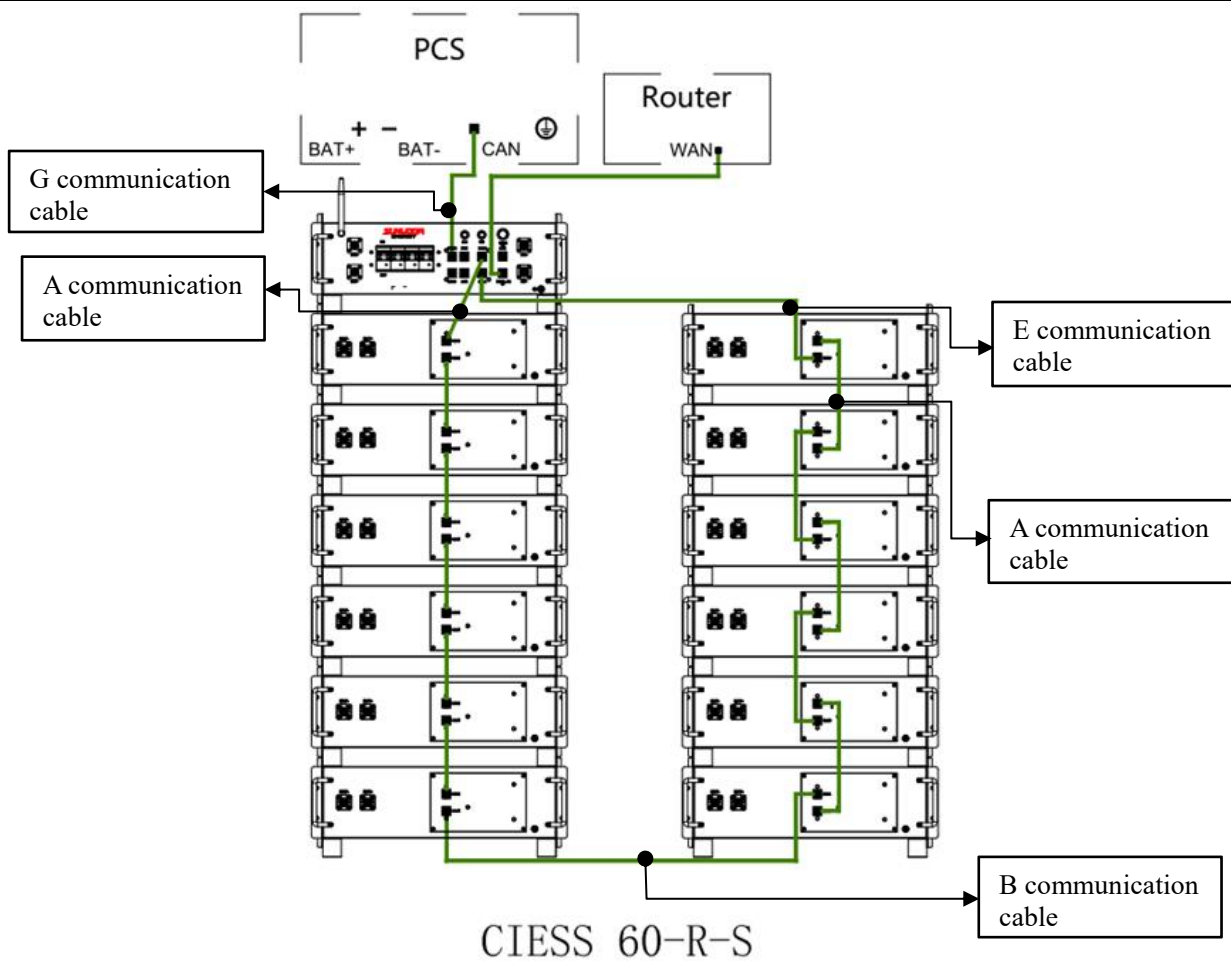

Fig. 4.16

4.5 Parallel wiring(Optional)

4.5.1 Ground connection for parallel machines

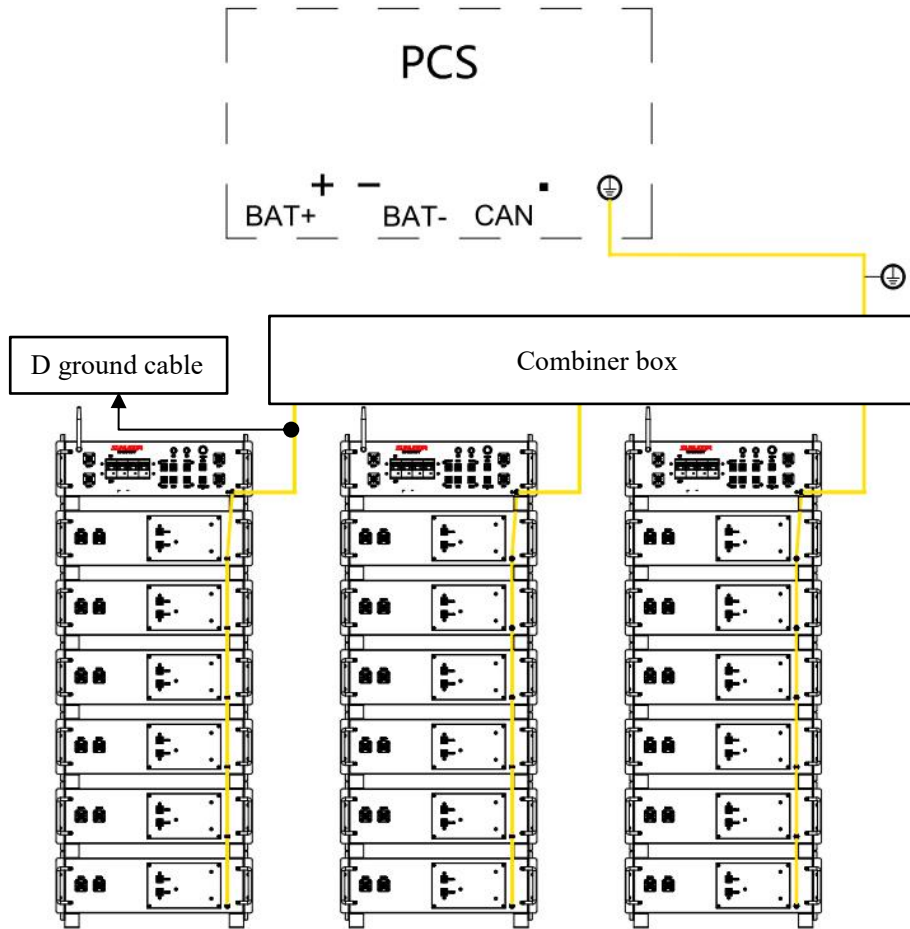

Fig. 4.17a CIESS 25/30-R-S ground connection for parallel mode
(Example of 3 clusters in parallel with CIESS 30-R-S)

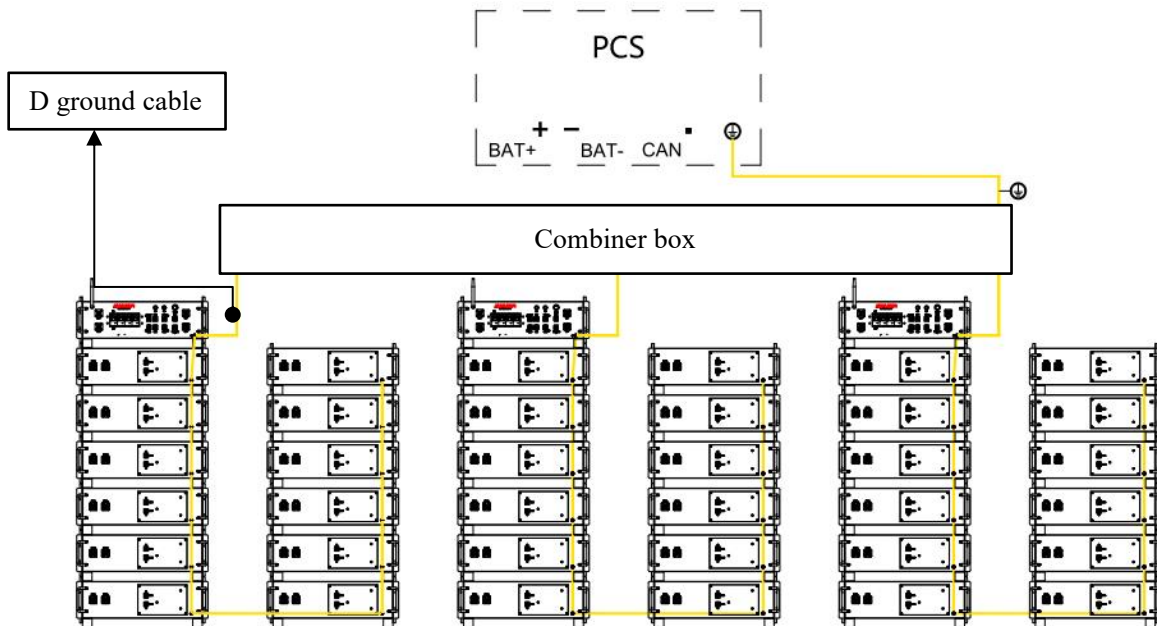

Fig. 4.17b CIESS 35~60-R-S ground connection for parallel mode

(Example of 3 clusters in parallel with CIESS 60-R-S)

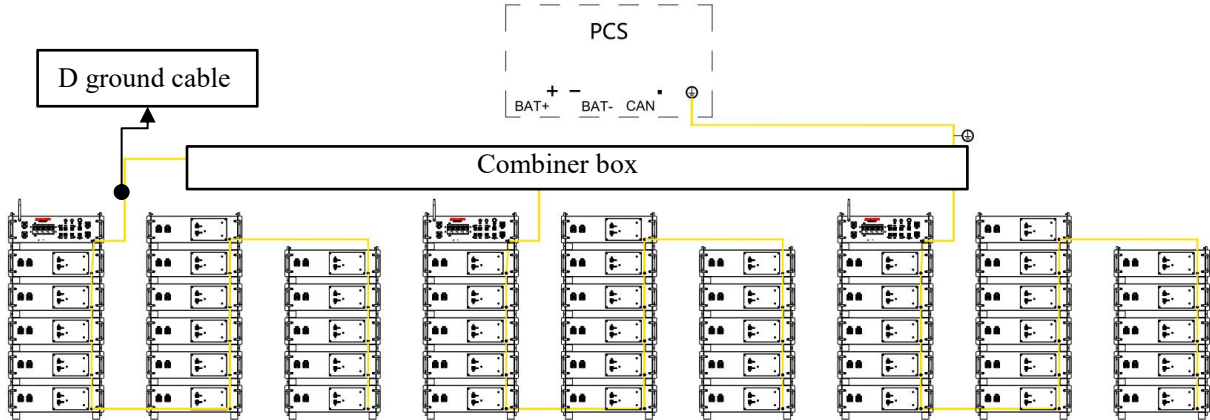

Fig. 4.17c CIESS 65~80-R-S ground connection for parallel mode
(Example of 3 clusters in parallel with CIESS 80-R-S)

4.5.2 Power cable connections for parallel machines

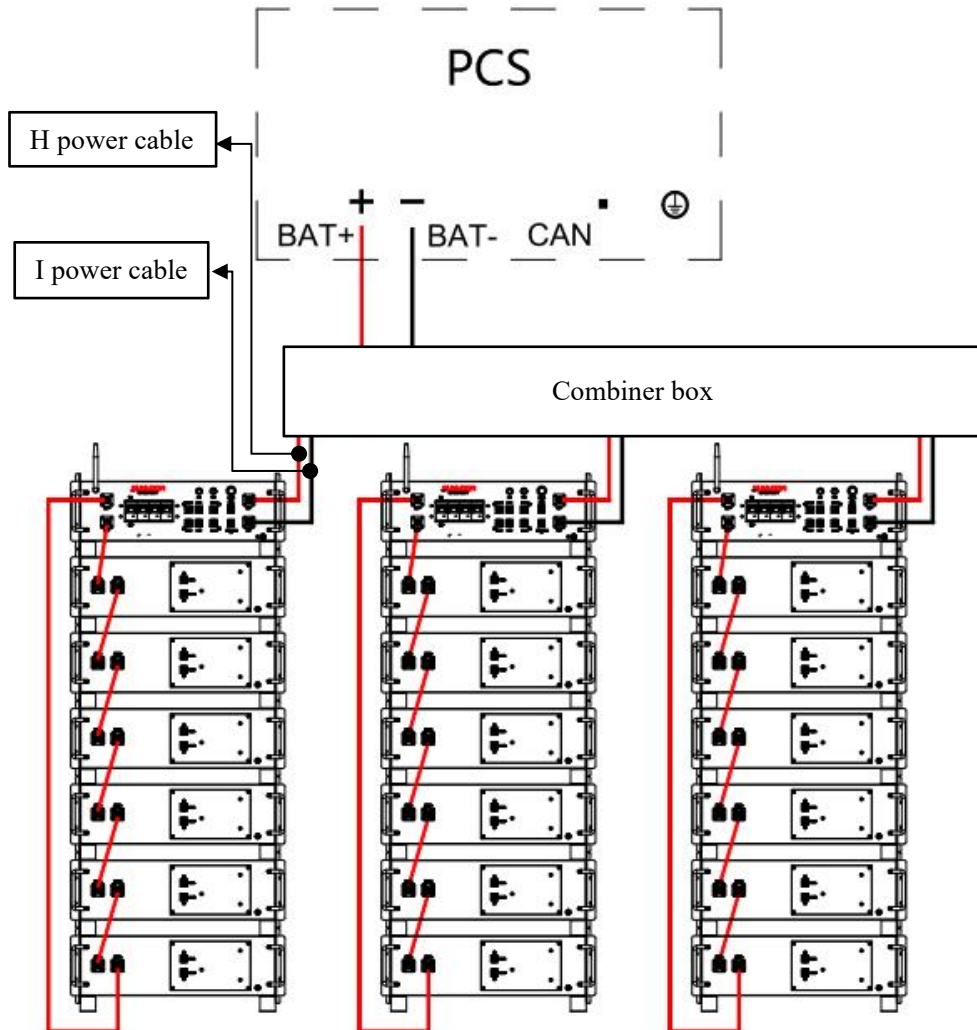

Fig. 4.18a CIESS 25/30-R-S power cable connection for parallel mode
(Example of 3 clusters in parallel with CIESS 30-R-S)

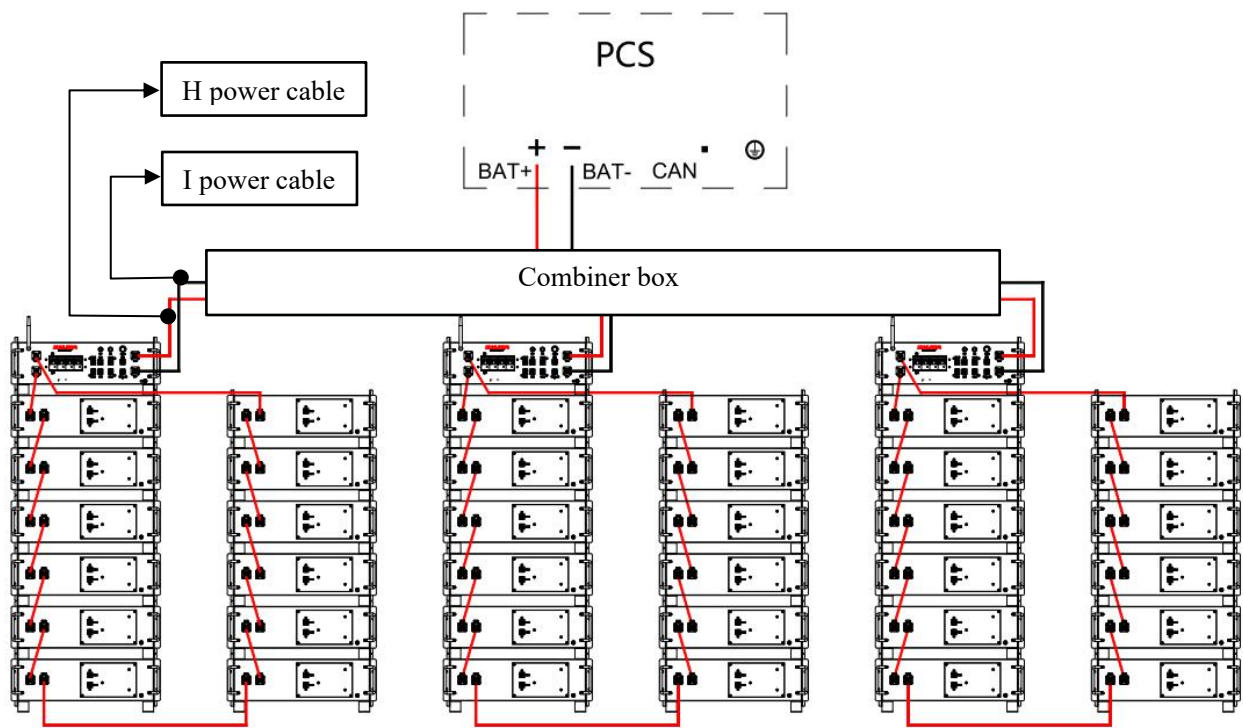

Fig.4.18b CIESS 35~60-R-S power cable connection for parallel mode
(Example of 3 clusters in parallel with CIESS 60-R-S)

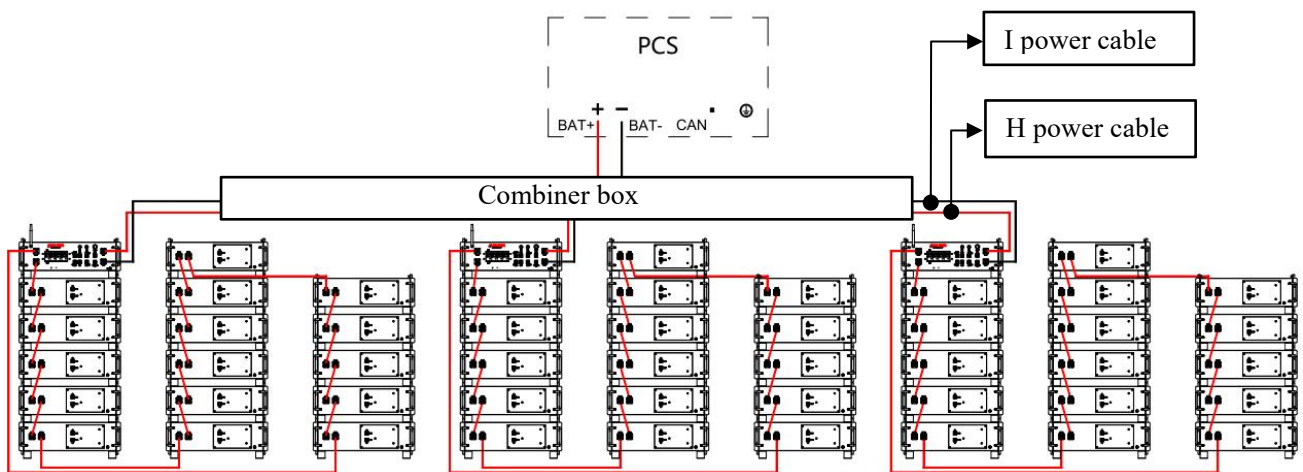

Fig. 4.18c CIESS 65~80-R-S power cable connection for parallel mode
(Example of 3 clusters in parallel with CIESS 80-R-S)

Notes:

- ① When machines are paralleled, H and I power cables are mainly connected to combiner box, when connecting to the combiner box, please cut the two 6AWG wire harnesses or 8AWG wire harnesses at the end as necessary.
- ② Please prepare the wiring cable from combiner box to inverter on site.

4.5.3 Communication cable connection for parallel machines

Note:

- ① Please default the system with the smallest SN code as the master one and connect its WAN port to the router.

- ② When paralleling, only the WAN port of the master needs to be connected to the router.

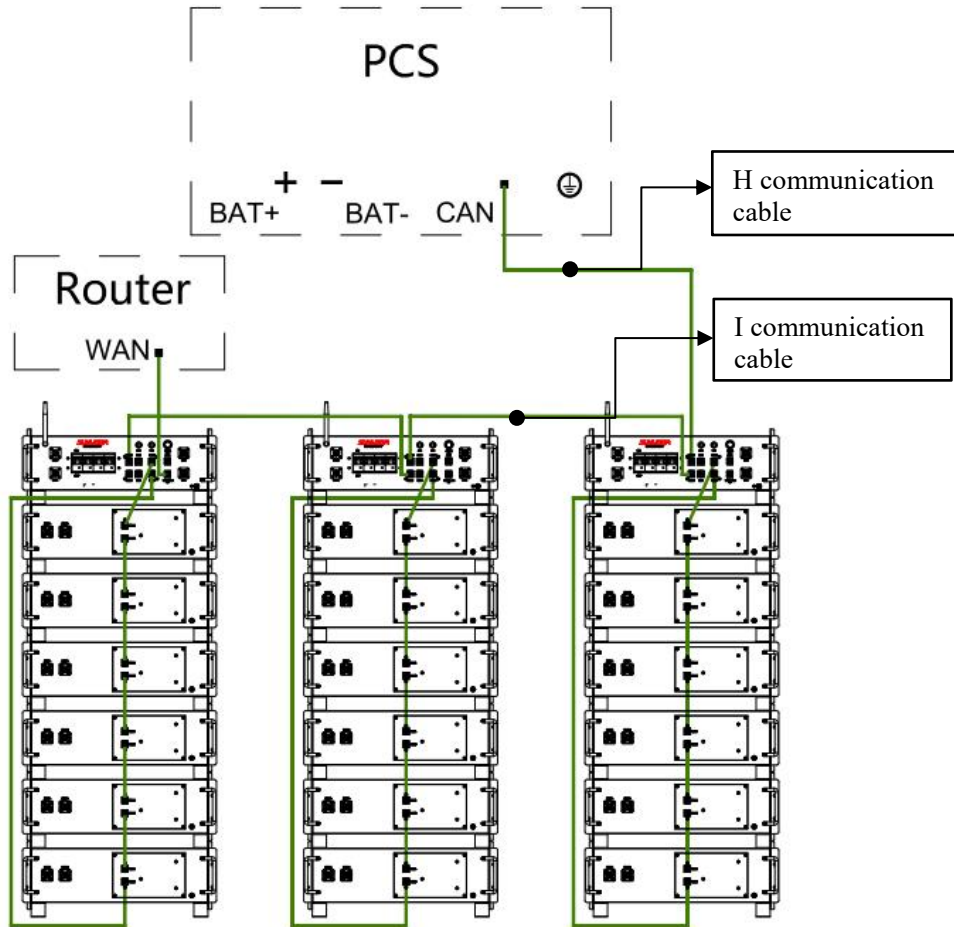

Fig. 4.19a CIESS 25/30-R-S communication cable connection for parallel mode
(Example of 3 clusters in parallel with CIESS 30-R-S)

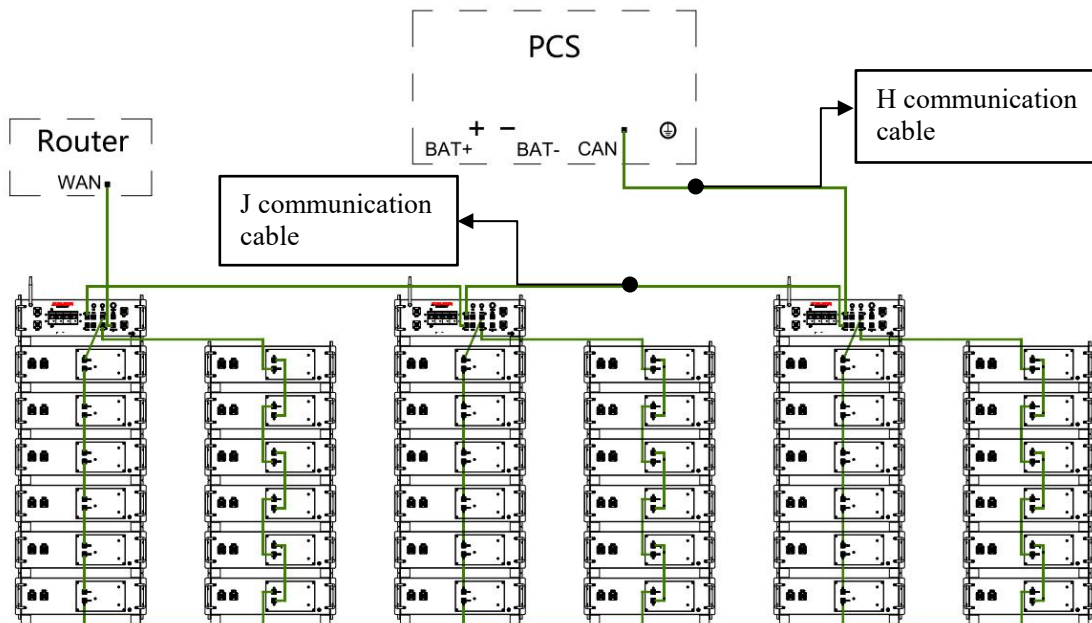

Fig.4.19b CIESS 35~60-R-S communication cable connection for parallel mode
(Example of 3 clusters in parallel with CIESS 60-R-S)

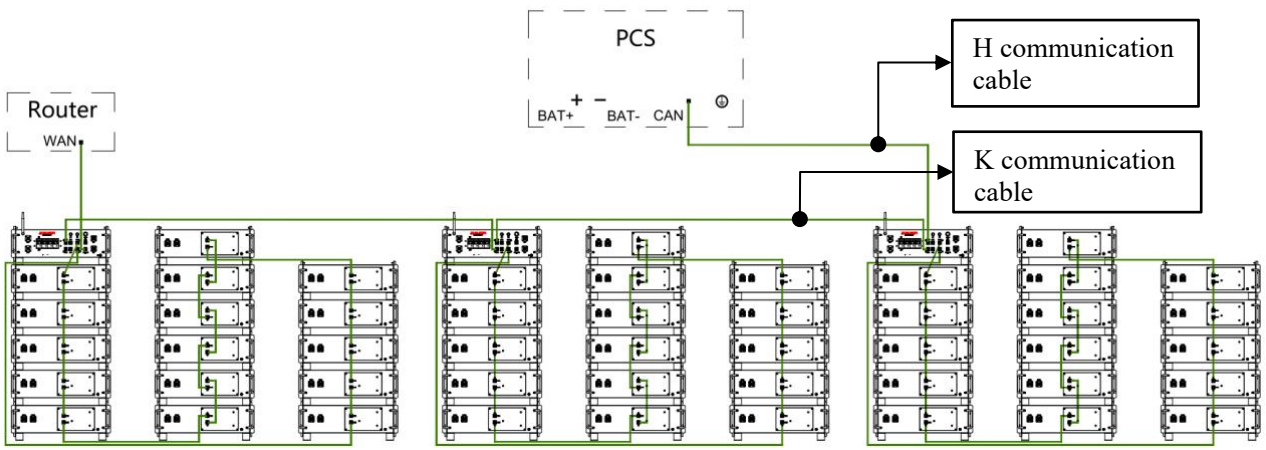

Fig. 4.19c CIESS 65~80-R-S communication cable connection for parallel mode
 (Example of 3 clusters in parallel with CIESS 80-R-S)

4.5.5 Complete Wiring Diagram for Parallel Machines

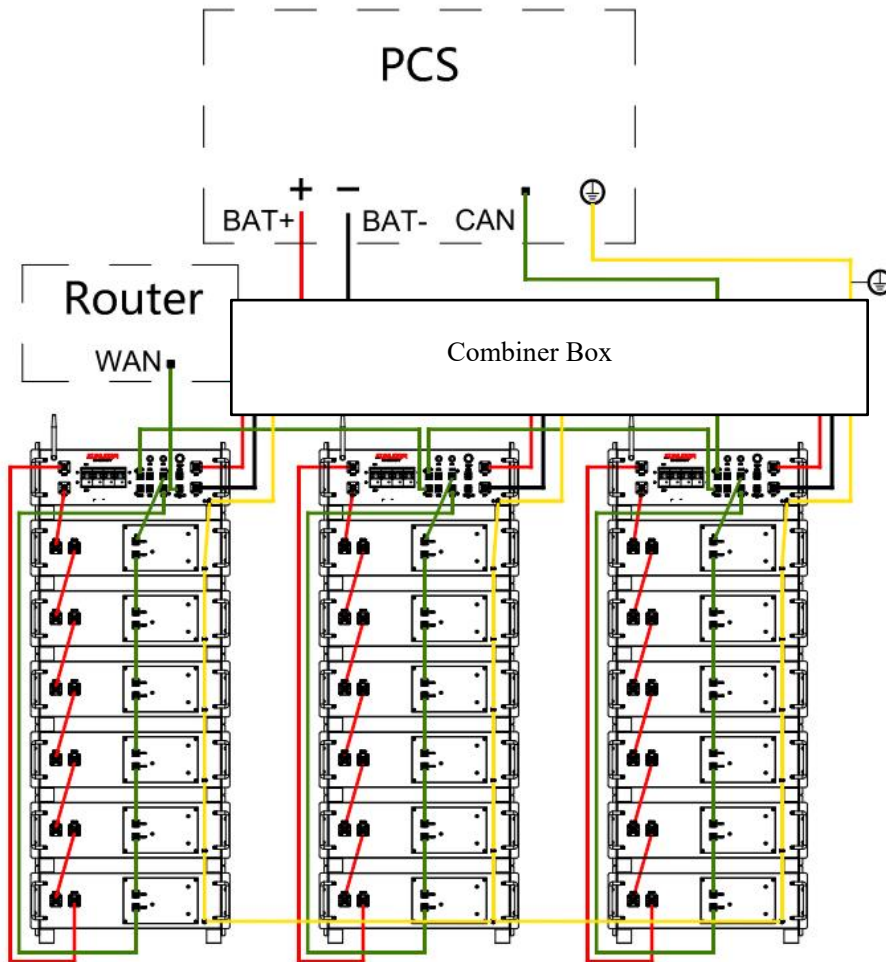

Fig. 4.20a CIESS 25/30-R-S cable connections for parallel mode
 (Example of 3 clusters in parallel with CIESS 30-R-S)

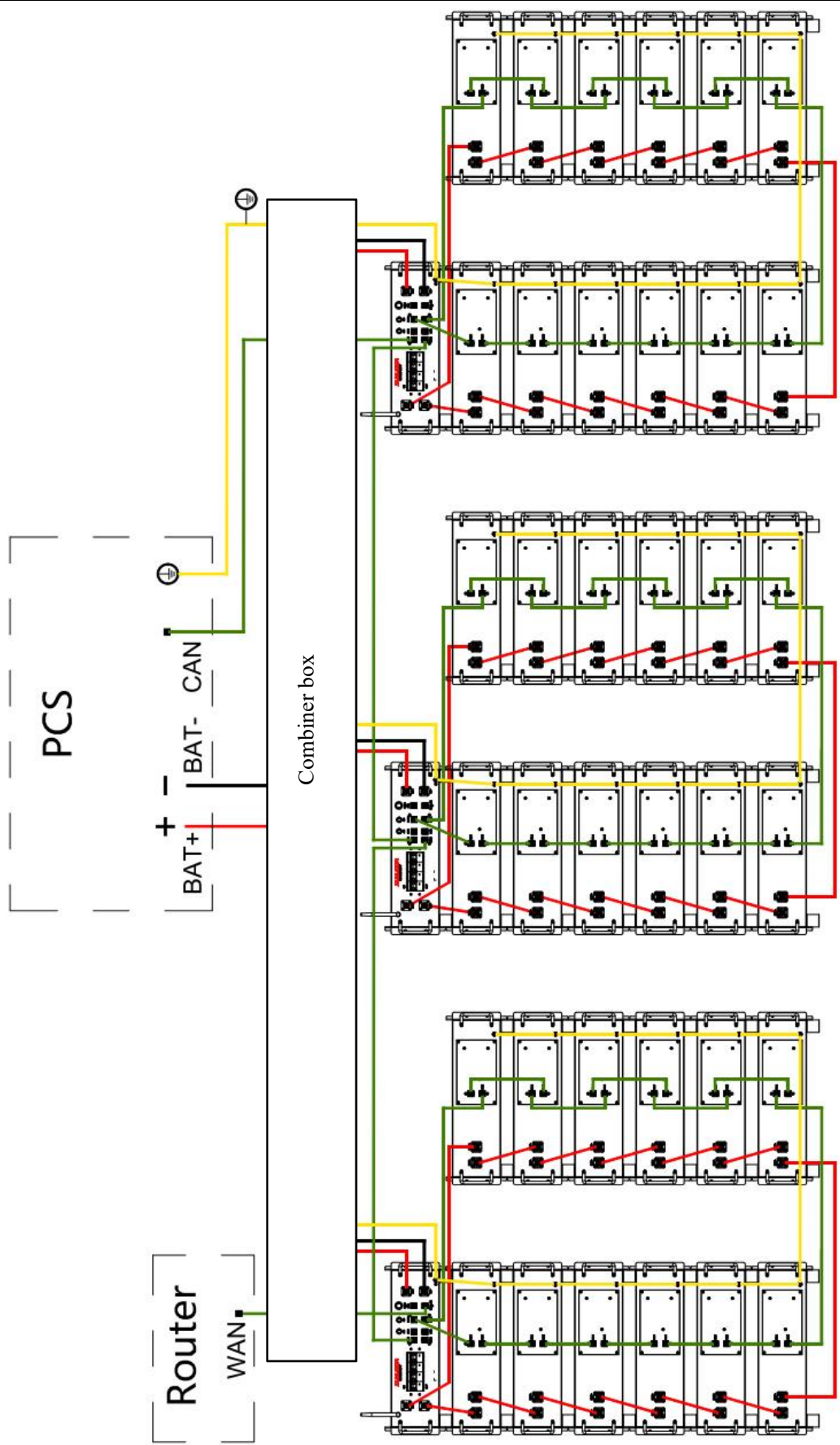

Fig. 4.20b CIESS 35~60-R-S cable connections for parallel mode
 (Example of 3 clusters in parallel with CIESS 60-R-S)

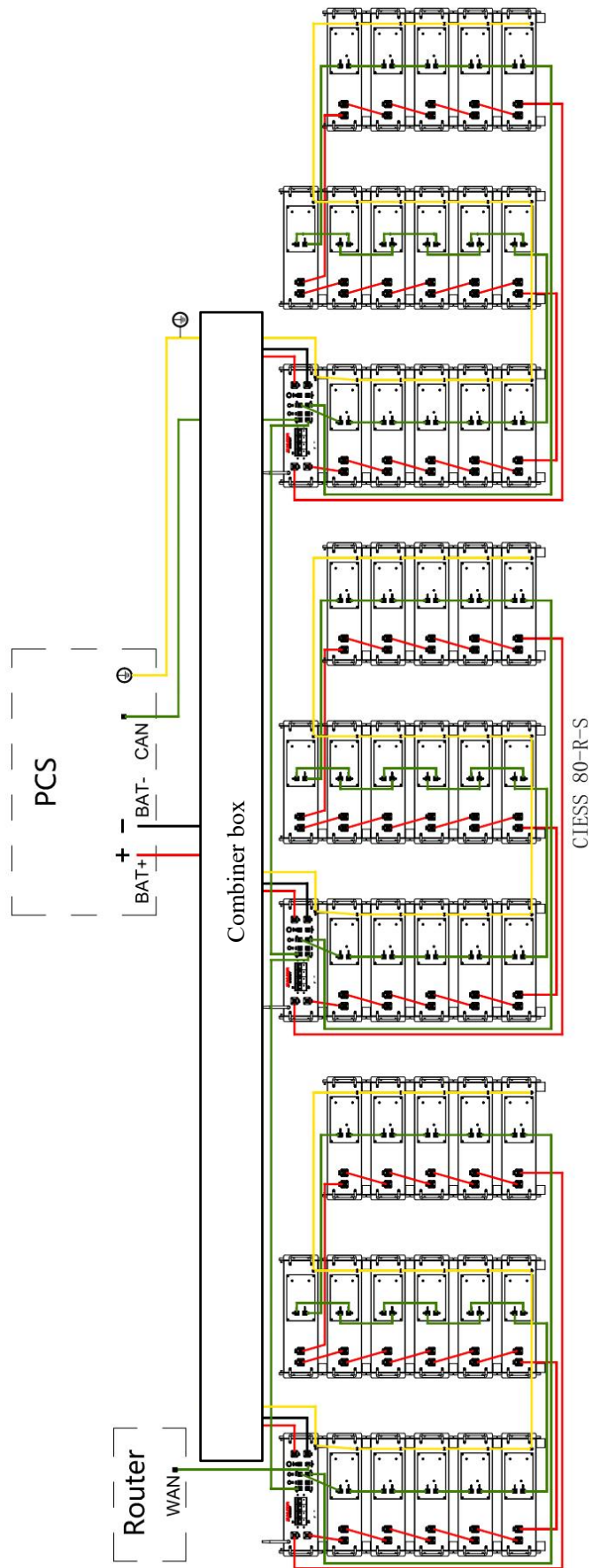

Fig. 4.20c CISS 65~80-R-Scable connections for parallel mode
(Example of 3 clusters in parallel with CISS 80-R-S)

5 Trial operation guidance

5.1 Description of indicator lights

Red light	Green light	Description
No light	Blinks once in 1s	Initialisation status, Starting status, Stopping status
No light	Always on	Running status
Always on	No light	Fault status

5.2 Power-on precautions

(1) Before powering up the system, ensure that the equipment is firmly installed, the installation location is convenient for operation and maintenance, the installation space is convenient for ventilation and heat dissipation, and the installation environment is clean and tidy.

(2) Before powering up the system, ensure that the ground wire, battery power wire, inverter power wire, communication wire, and inverter AC wire are connected correctly and securely.

(3) Before powering up the system, ensure that the cable ties meet the alignment requirements, are reasonably distributed, and are not damaged.

(4) Before powering up the system, ensure that all switches are disconnected.

5.3 Power-on guidelines

Step 1: Open the air switch on the control box following the arrow shown in the figure below.

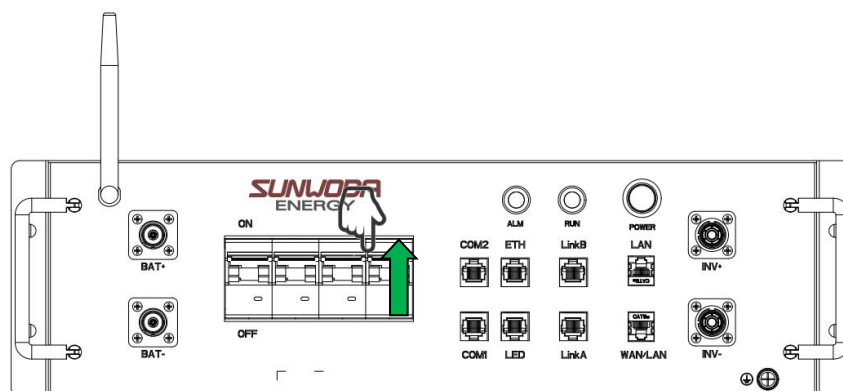

Figure 5.1

Step 2: Press the POWER button of the main control box for 3s until the running indicator flashes green steadily at a frequency of 1s1 times. At this time the battery is switched on.

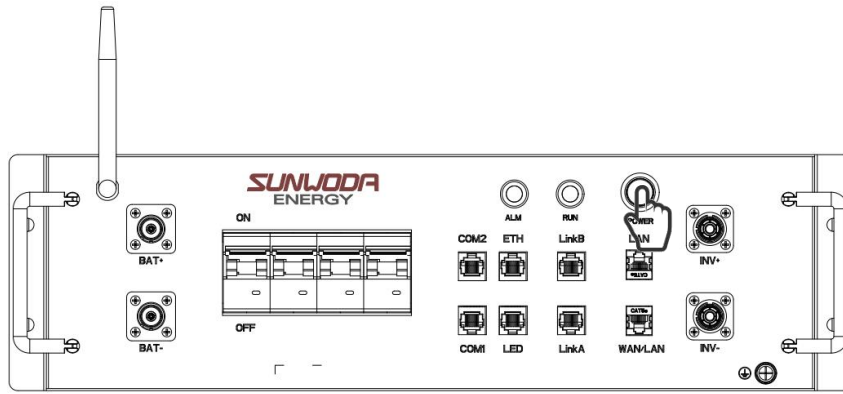

Figure 5.2

5.4 Power-off guidelines

Step1. Press the front POWER button for 3 seconds until the run light goes out and the battery turns off.

Step2. After that, put the air switch on control box to off state to shut down the system.

Notes:

Before powering off the battery system, make sure there is no load on the AC side of the inverter and that the circuit breaker between battery system and inverter is disconnected.

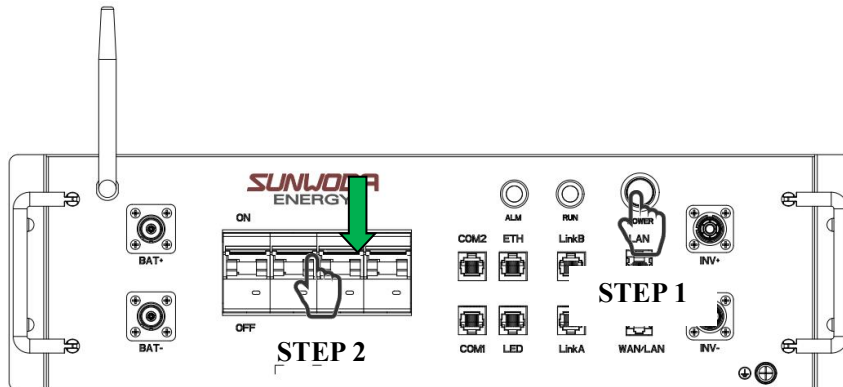

Figure 5.3

6 Product Maintenance and Troubleshooting

6.1 System maintenance

(1) The system needs to be recharged every 6 months from the factory.

(2) When the equipment is not used for a long period of time, the battery needs to be charged to between 45% and 55% of its capacity and the battery output needs to be disconnected to avoid emptying.

(3) During the storage period, the system should be inspected regularly by professional personnel to check whether the wiring is loose or detached, or to clean the surface of the system; if any defects are found, please contact the distributor in time.

Dangerous

When operating and maintaining the battery system, always de-energise the battery system. Operating the equipment while energised may result in damage to the battery system or a risk of electric shock.

Warning

If you find any problems that may affect the battery system or the storage inverter system, please contact the after-sales personnel immediately, and never disassemble it privately.

If you find that the internal copper of the conductive wire is exposed, it is forbidden to touch it, and notice there maybe a a high-voltage danger. Please contact the after-sales personnel immediately and never dismantle it privately.

If other emergencies occur, please contact after-sales personnel at the first time, operate under the guidance of after-sales personnel, or wait for after-sales personnel to operate on site.

6.2 Troubleshooting





Fault type	Fault reason	Solutions
Battery cannot be switched on	Battery voltage is too low	Please contact our after-sales service for battery maintenance, do not blind charge by yourself;
	The breaker on control box is not closed.	Close the circuit breaker;
	Button closing time is too short	Button closing time $\geq 3s$;
	Power button is not working	Change the pushbuttons;
Short discharge time	Lower battery capacity	Maintains a higher state of charge of the battery system, i.e. higher SOC;

	Equipment overload	Check load status and remove non-critical loads;
	Loss of capacity due to battery ageing	Confirm SOH status, if abnormal, please contact our after-sales;
	Outside the specified working environment range, the system itself derated	No need to deal with it, the system will recover by itself after the environment is restored;
Unable to charge or discharge	Internal error	Contact our after-sales service, and please do not disassemble the equipment by yourself;
	Battery feedback charging/discharging protection fault	1. Let it stand for a period of time and check whether the system is back to normal. 2. Contact our after-sales service, and please do not disassemble the equipment by yourself;
	Battery over-discharged to SOC protection value	Charge the battery for a while and try again afterwards.
	Battery over-temperature	System temperature returns to normal range;
Communication abnormality	Communication with BMU	Check if the battery daisy chain communication connection is reliable and restart the system;
	Communication with PCS	1. Check whether the PIN foot wiring is correct; 2. Check whether the BMS protocol parameters are correct; 3. Check whether the PCS battery option setting is correct; 4. Check whether the CAN bus matching resistor is appropriate;
Insulation abnormality	Unreasonable enabling configuration	1. Confirm whether the PCS has insulation detection and reasonably configure the BMS enabling parameters; 2. Confirm whether it is a multi-cluster parallel machine, and the insulation detection cannot be fully enabled in multi-cluster parallel machine;
Red LED Running	Failure to start-up the machine	Please contact our after-sales service;
	Power-up failure	Check whether the system parameters are

		consistent with the requirements of the application scenario;
	Others	According to the fault information (fault code) displayed on the PCS side, check the PCS fault table to find out the corresponding cause.
Electrical shock from enclosure	System not effectively grounded	Connect the system grounding terminal effectively and reliably according to the installation manual;
Inverter fails to start	Battery voltage too low or SOC below shutdown protection value	Charge the battery after starting the inverter via the grid;
Battery cannot be charged through the grid	Battery Setting interface does not select “Allow Grid Charge” or Time of Use interface does not select “Allow Grid Charge”.	1. Check whether Battery Setting > Grid Charge is enabled in the LCD screen on PCS; 2. Check if System Work Mode > Time of Use > Grid Charge is enabled in the LCD screen on PCS;
	Battery Fault Protection	Please contact the after-sales staff to deal with it, and please do not disassemble it by yourself;
	Grid abnormality	Check whether the grid voltage is normal;

7 Transportation and storage

7.1 Transportation requirements

 Dangerous
Prohibit rough loading and unloading, violent vibration, shock or extrusion, prevent sunlight and rain, otherwise it may lead to short-circuit, damage (liquid leakage, rupture, etc.), fire or explosion of the battery.
 Warnings
Make sure the unit is balanced during handling to avoid dropping it.
Do not transport the device through the terminals, bolts or cables of the battery to avoid damage to the battery.
The equipment should be transported in the required direction, and should not be inverted, tilted, dropped, or mechanically impacted. In addition, do not let the device suffer from rain and snow in the process of handling and fall into the water.
 Notice
Batteries are certified to UN38.3, which is classified as Class IX Dangerous Goods.
Comply with the international transport rules for dangerous goods and meet the regulatory requirements of the transport authorities of the country originating from, travelling through and destination to.
When transporting, please choose sea transport or road with good condition, railway and air transport are not supported. Bumps and tilts should be minimised during transport.
Before transport, check whether the packaging of the battery is intact and undamaged, and there is no odour, liquid leakage, smoke, fire, etc. Otherwise, no transport is allowed.
When handling the battery, it should be gently held and put down, it is strictly prohibited to bump the battery, and pay attention to personal safety.
The transport box must be firm, and care should be taken during loading,unloading and transporting, and moisture-proof measures should be taken.
 Important to know
Heavy loads must be handled with balanced and smooth force; the speed of movement should be even and low; and the positioning procedure should be smooth and slow to avoid any impact or fall, etc., which may scratch the surface of the equipment or damage the component parts and cables of the equipment.
When carrying heavy loads, special care should be taken on the working table, slope, stairs and some easy to slip places, when carrying heavy loads through the threshold, make sure that the width of the door is enough to enable the equipment to pass through, in order to

prevent bumping or bruising the fingers.

When using a forklift to move, the forklift must be forked in the middle position to prevent tipping over. Before moving, please fasten the equipment to the forklift with a rope; when moving, it needs to be guarded by a person.

The tilting angle of the cabinet should meet the requirements, the tilting angle should be $\alpha \leq 15^\circ$ with packing, and $\alpha \leq 10^\circ$ after removing the packing.

When carrying the equipment by hand, wear protective gloves, labour insurance shoes and other safety protection equipment to avoid injury.

7.2 Storage requirements

Warnings

The battery should be stored indoors. No direct sunlight or rain, with dry and well-ventilated environment, clean surroundings, no large amounts of infrared and other radiation, no organic solvents or corrosive gases, no metallic conductive dust, etc., and away from heat and fire sources.

If the battery is bulging, deformed, broken or leaking liquid, it shall be scrapped without regard to the storage time.

When storing the battery, it should be placed correctly in accordance with the identification of the box, and it is strictly prohibited to place it upside down, sideways, or at an angle, and when stacking it, it should be in accordance with the yardage requirements on the outer packaging.

The site must be equipped with fire-fighting facilities that meet the requirements, such as fire sand and fire extinguishers.

Notice

Batteries are recommended to be used in a timely manner, for long-term storage, please carry out recharge processing regularly, otherwise it may lead to battery damage.

The ambient air cannot contain corrosive or flammable gases, and the battery system cannot be tilted or stored upside down.

Important to know

During storage, it is necessary to keep relevant proof that the product storage requirements are in accordance with requirements, such as temperature and humidity log data, photos of the storage environment and inspection reports.

Store in a clean and dry place and protect from dust and water vapour. Avoid erosion by rain or water on the ground.

Storage environment requirements:

Recommended storage temperature: 20° C to 30° C.

Relative humidity: 5% RH ~ 80% RH.

Dry, ventilated and clean. Avoid contact with corrosive organic solvents, gases and other substances.

Avoid direct sunlight. The distance from the heat source should not be less than two metres.

Battery maintenance is required at intervals of up to 6 months from the date of shipment from the manufacturer; the recharge intervals to prevent the battery from empty are required as follows:

Ambient temperature (30,40] °C : should be replenished within 15 days; ambient temperature $\leq 30^{\circ}\text{C}$: should be replenished within 30 days.

The storage charge state is recommended to be maintained at 45% to 55% SOC.



Shenzhen Sunwoda Energy Technology Co., Ltd.

Sunwoda Industrial Park, No.18 Tangjia South Road, Guangming New District, Shenzhen, China
www.sunwodaenergy.com