

Quick Installation Guide

SolarEdge Nexis Solution 3ph

For Australia, only Inverters NX-10K /
NX-15K / NX-20K are available.

In this guide you will find:

1. [What's in each Box](#)
2. [What you need for the installation](#)
3. [Before you start](#)
4. [Let's get started!](#)
5. [Commissioning and indicators](#)



For the SolarEdge Nexis
Information center, [click here](#)



MAN-01-01400-1.0

SolarEdge.com

SolarEdge Technologies GmbH, Werner-Eckert-Str. 6, 81829 Munich, Germany
Subject to change without notice.

© SolarEdge Technologies, Ltd. All rights reserved. February 2026.

V01

What's in Each Box

Box 1- Inverter 3ph

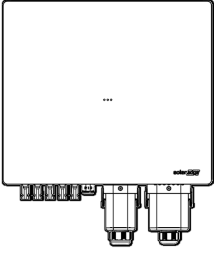

SolarEdge Nexus
Inverter 3ph

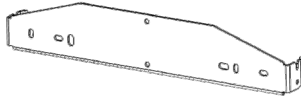

Inverter wall
bracket

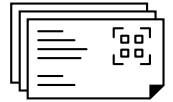

Power rating
labels x6

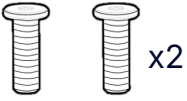

M5 screws

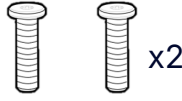

M4 screws



What's in Each Box

Box 2- Battery Link

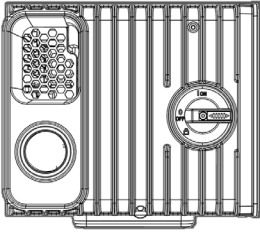

Battery Link

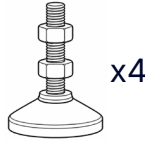

x4

Battery Block foot



Wall bracket

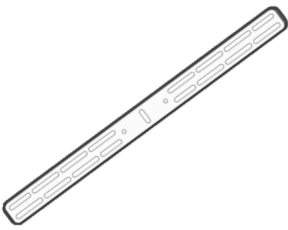

Wall bracket extension
(for use in NAM only)

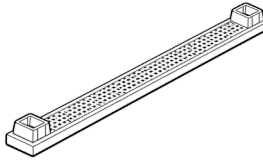

Battery Block filter

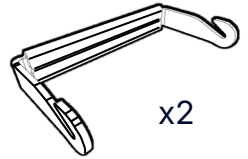

x2

Battery Block handle

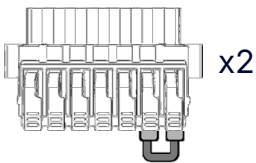

x2

Communications connector

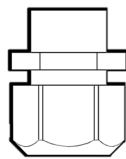

Cable gland
(for use in EU only)



x4

Screws
M5X12



What's in Each Box

Box 3 - Battery Block

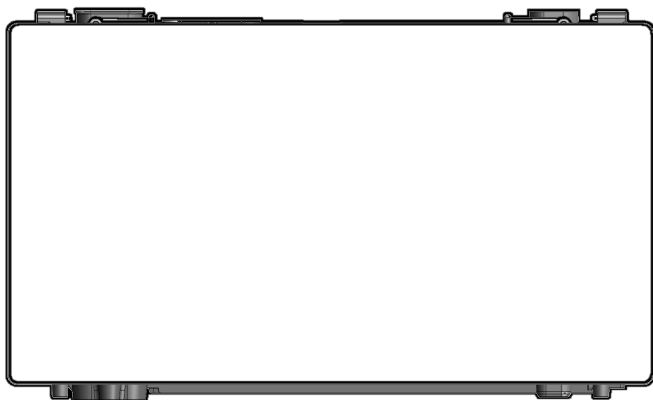

SolarEdge Nexis
Battery Block

Sold separately!

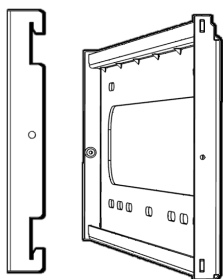

SolarEdge Nexis
Wall Mount Bracket



Tools Needed:

What You Need for the Installation

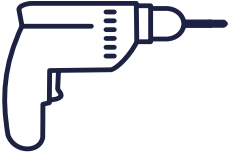

Drill

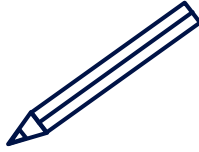

Pencil

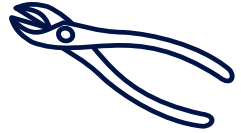

Wire cutter



Wire Stripper



RJ45 crimping tool



Hammer

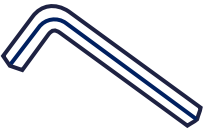

M4, M5
Allen keys

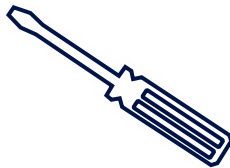

Watchmaker
flat screwdriver



Torque wrench



Level

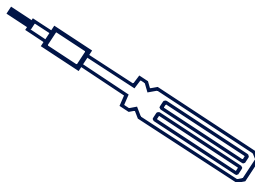

Adjustable Torque
Torx Screwdriver set

x4

x4



Mounting screws
and wall plugs



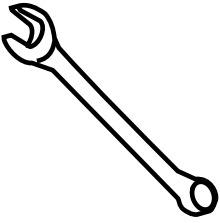

1/2" wrench



CAT7 cable

Symbol Legend



RECOMMENDED



TORQUE: A torque value in Nm



IMPORTANT NOTE



WARNING!

This symbol denotes a hazard. The symbol calls attention to a procedure that could result in injury or loss of life if not correctly performed or adhered to. Do not proceed beyond a warning note until the conditions are fully understood and met.



CAUTION!

Denotes a hazard. The symbol calls attention to a procedure that could result in damage or destruction of the product if not correctly performed or adhered to. Do not proceed beyond a caution sign until the indicated conditions are fully understood and met.



Before you start

System Overview, PV + Storage

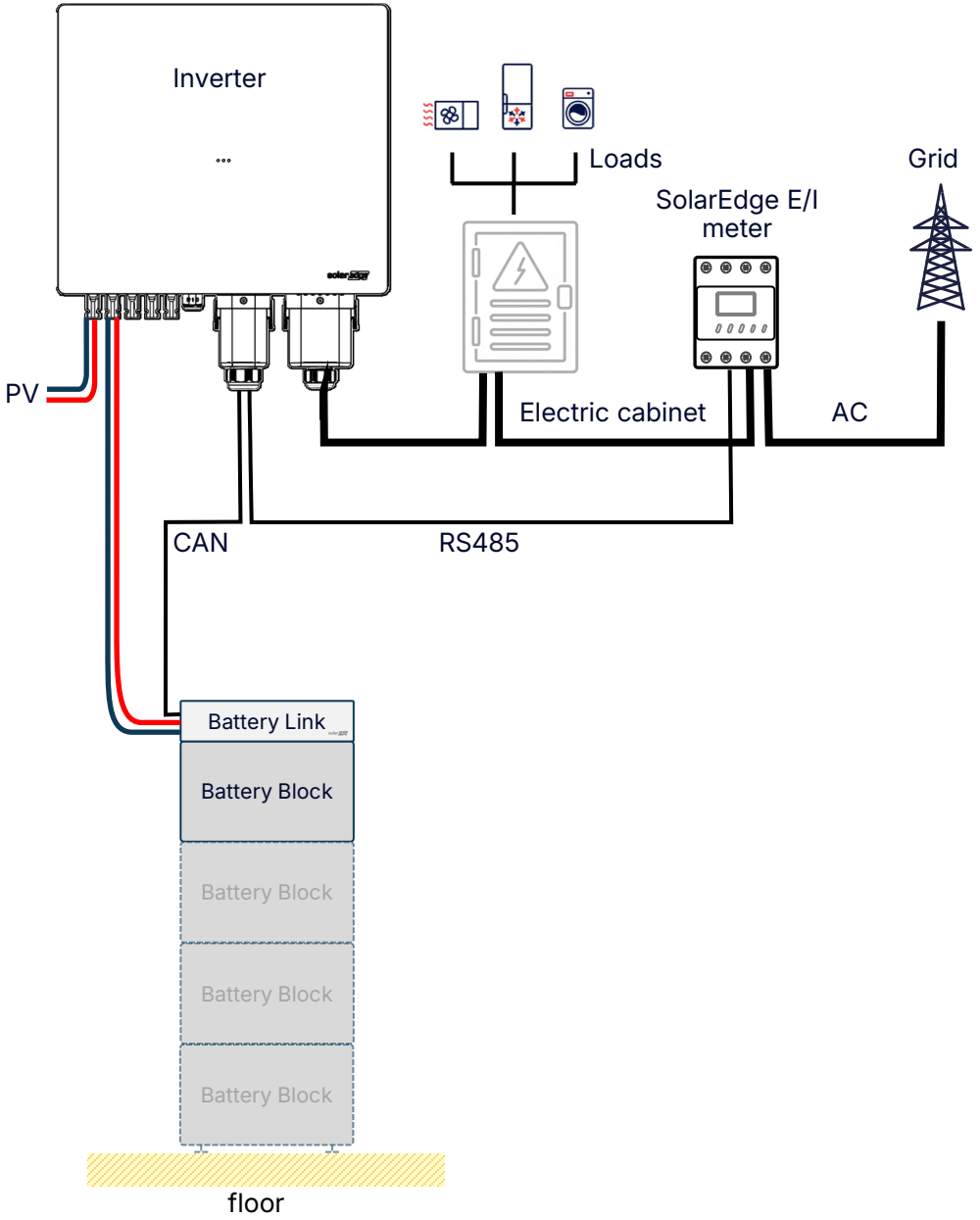

Before you start

System Overview

Full Home Backup

For partial Home Backup see [Appendix 1](#)

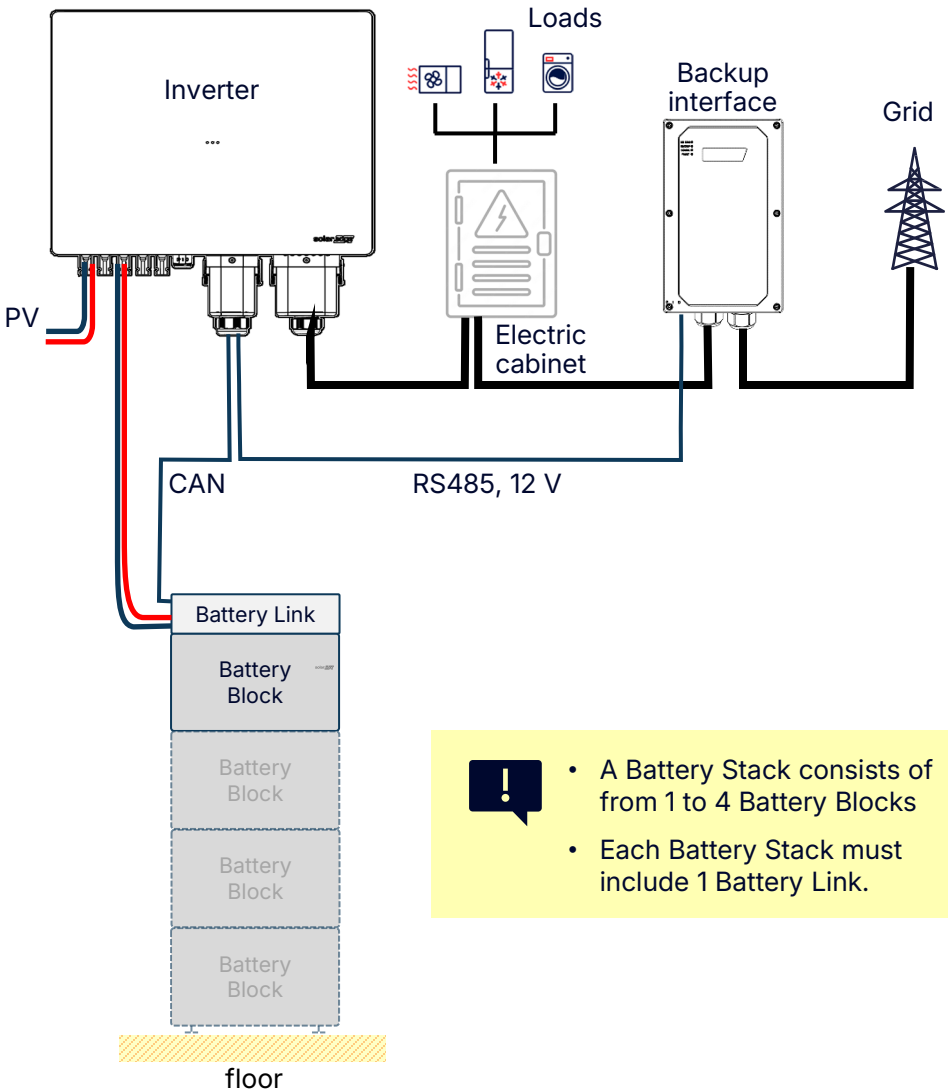

- A Battery Stack consists of from 1 to 4 Battery Blocks
- Each Battery Stack must include 1 Battery Link.



| Let's get started!



1. First, install the Inverter.
2. Next, install the Battery.
3. Finally, when applicable, install the meter and/or the Backup Interface (BUI).
4. For a site with multiple inverters, check [here](#).

A. Planning

Indoor
Room size
 $\geq 60 \text{ m}^3$



Outdoor

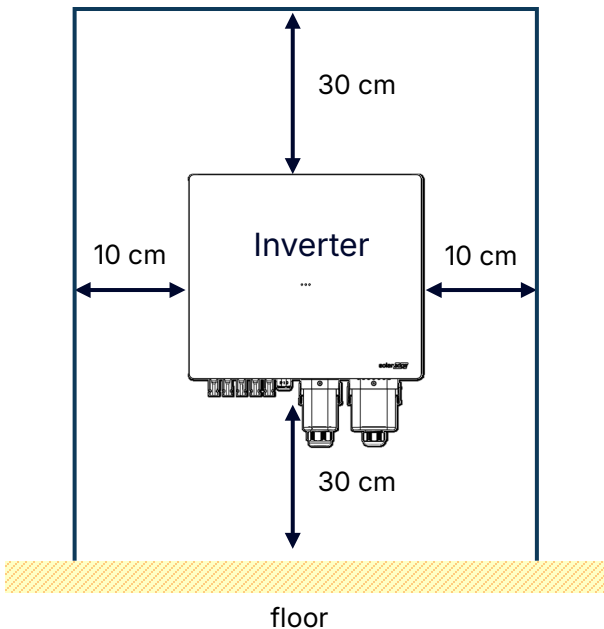

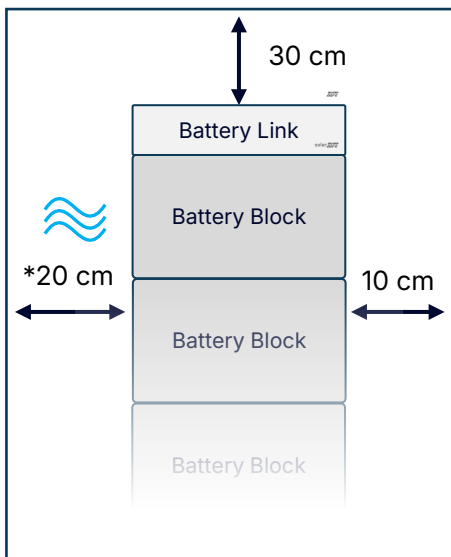
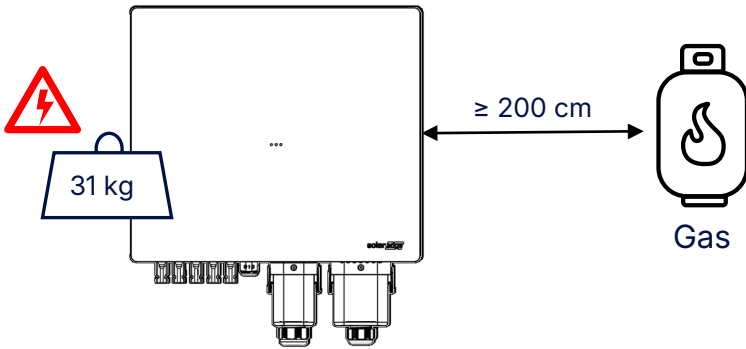
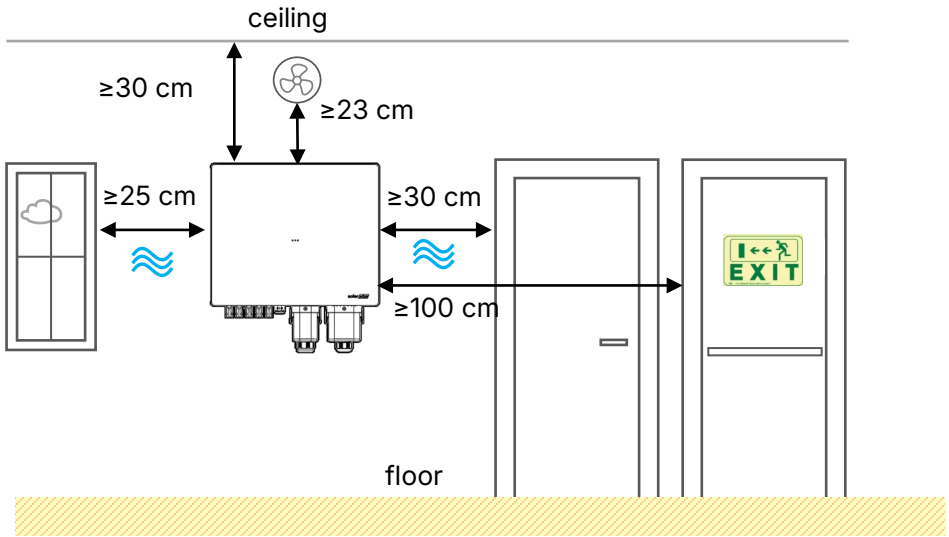



- !**
- *10 cm is allowed, but 20 cm is recommended for servicing the Battery Block/s.
 - Minimum distance to window or door is 30 cm
 - Assuming a shielded CAT7 comms cable and at least 6 mm² DC cables, the maximum distance between the Inverter and the furthest Battery Stack is 50 m.

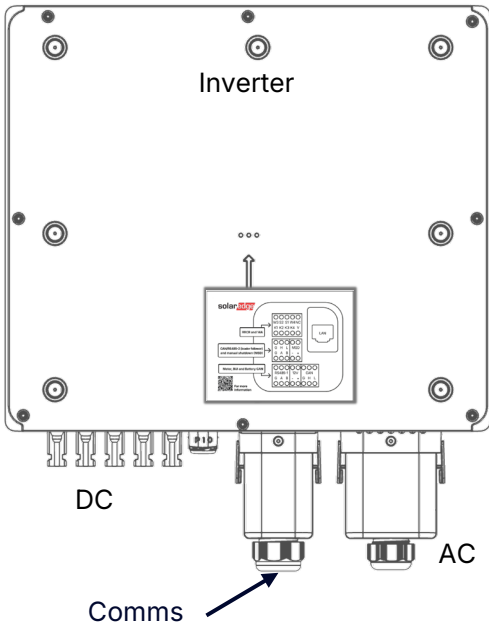

B. Wiring Considerations



- 
 - Use either the left or the right side of the battery link for connection to the inverter (DC, Comm and GND)
 - Connection of DC cables from the Battery Link to the Inverter should be + to +, and - to -
 - Communication and GND as indicated on the product
 - Maximum distance between the furthest battery and the inverter is 50 m when using 6 mm² DC cable and shielded CAT7.

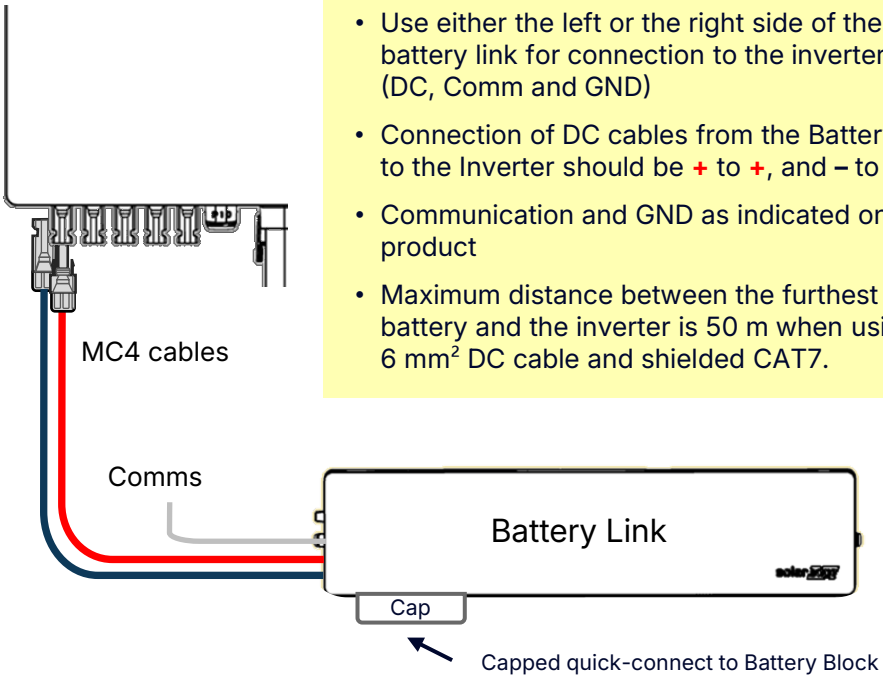

C. System General installation guidelines

Order of installation

Power OFF all devices and all circuit breakers.



Mechanical installation



Wiring:

- Inverter
- Battery
- BUI / Meter
- Accessories



Power ON:

- Backup interface
- Battery Link
- Inverter CB; P/1/0
- Accessories



Auto software updates

* Only applicable for wired ethernet systems!

To save valuable commissioning time, we recommend that you first connect the inverter to the battery, internet, and the AC, and then turn the system ON for background software updates. You can then proceed with other installation activities while the software is updating.



D. System Configuration

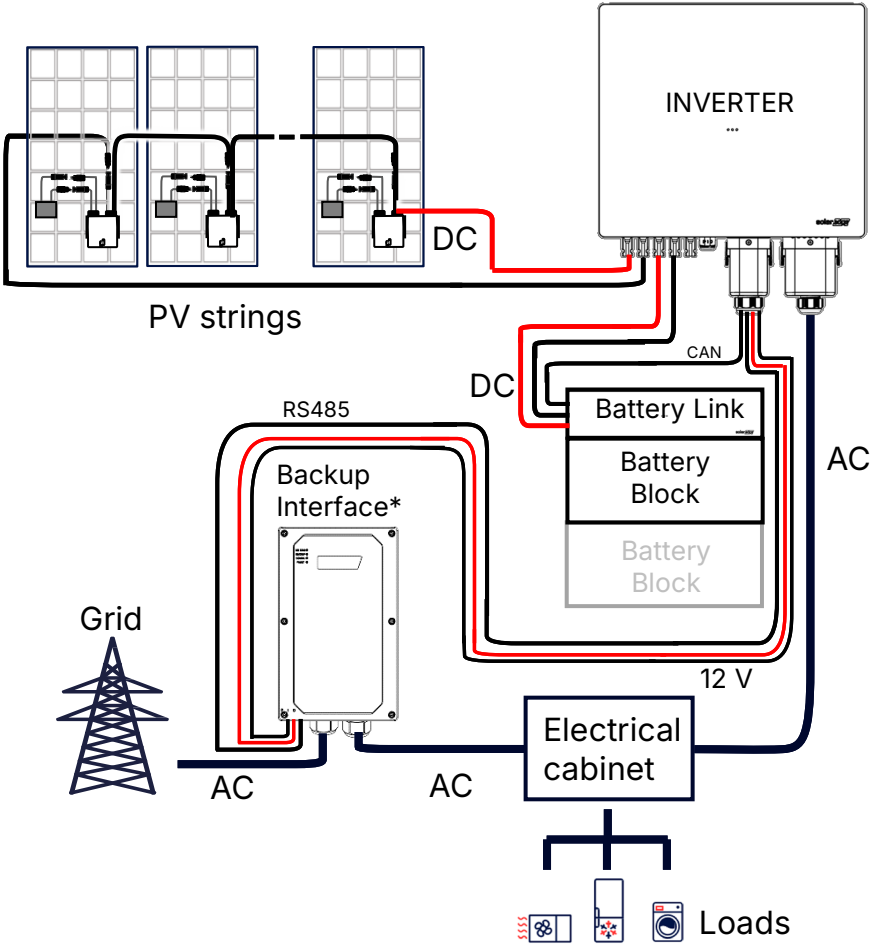

*For the Quick Installation Guide for the Backup Interface, click [here](#).



Mounting the inverter

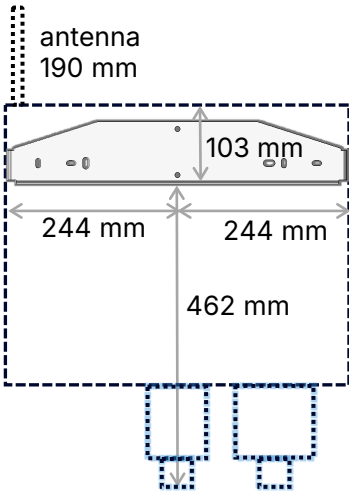

Use these measurements to ensure that the inverter will easily fit in the planned space available when attaching the wall-mount bracket to the wall.

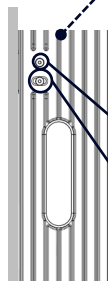
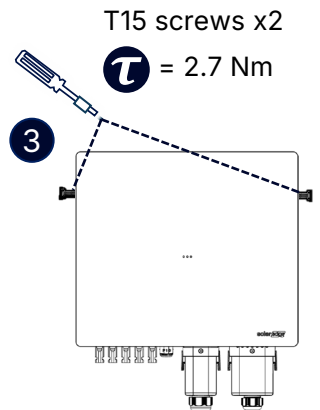
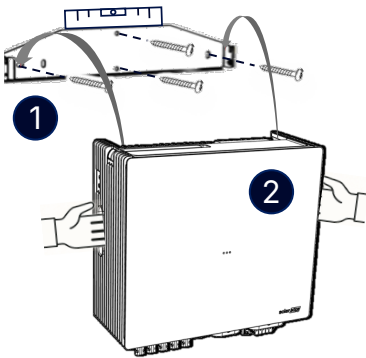

- Pre-assembled pins to hang the inverter on the bracket. Do NOT unscrew!
- Screws x2 used as to secure the inverter to the bracket



Wiring the inverter



Before wiring:

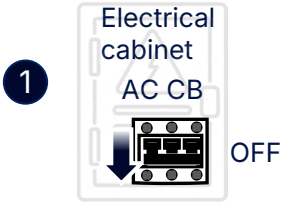

2

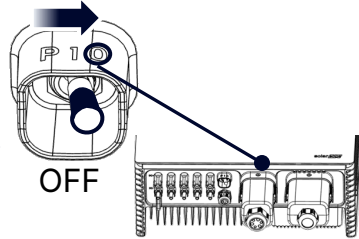

Wait at least 5 minutes before moving to Step 3.

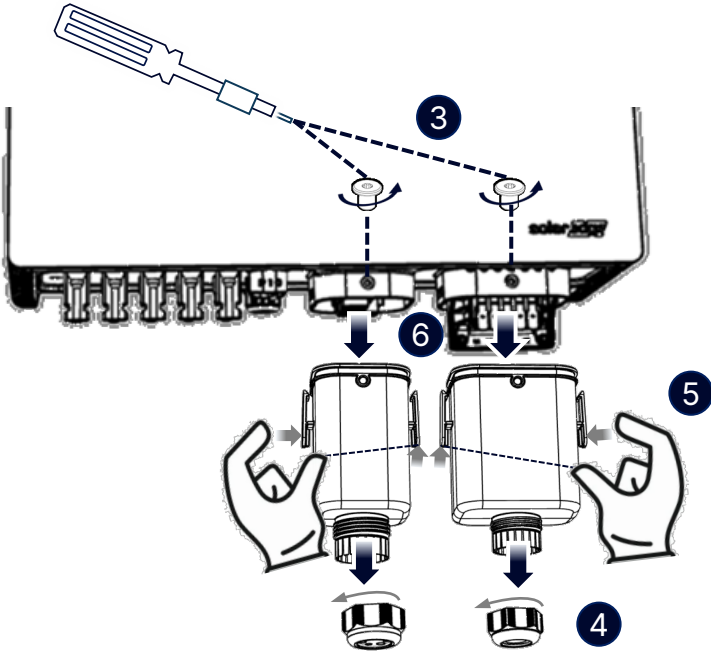

Wiring the inverter AC

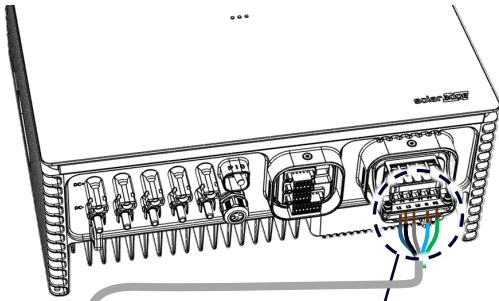

AC

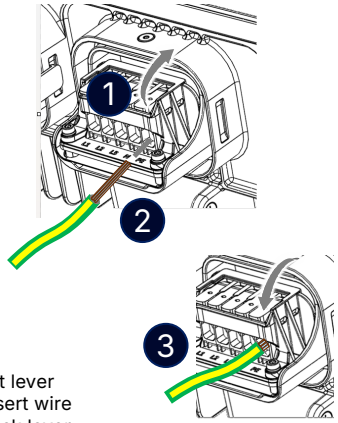

1. Lift lever
2. Insert wire
3. Lock lever
4. Check that the wire is securely connected

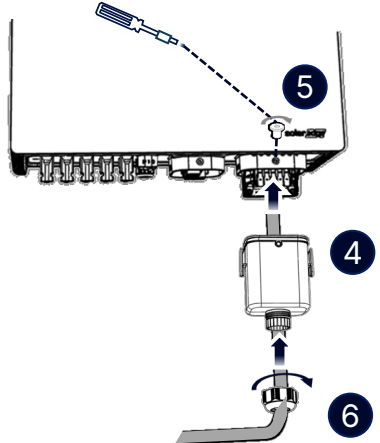
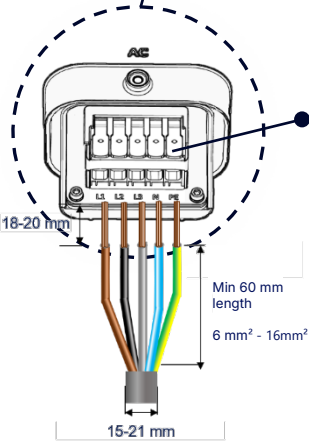

When planning to upgrade to a Backup system, make sure to consider the Backup power which may be higher than the original On-grid AC production.



Make sure that the circuit breaker rating matches the continuous current and the power rating of the inverter according to its datasheet.

Inverter	Circuit breaker
8 kW	16 A
10 kW	20 A
13 kW	25 A
>13 kW	32 A

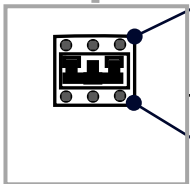

Grid

Electrical cabinet

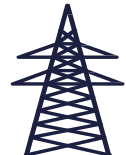

The unit is compatible with an RCD Type A



Wiring the inverter DC



Connect PE/grounding cable to the grounding bar according to electrical standards and local regulations. Use cable diameter \geq the AC cables diameter.

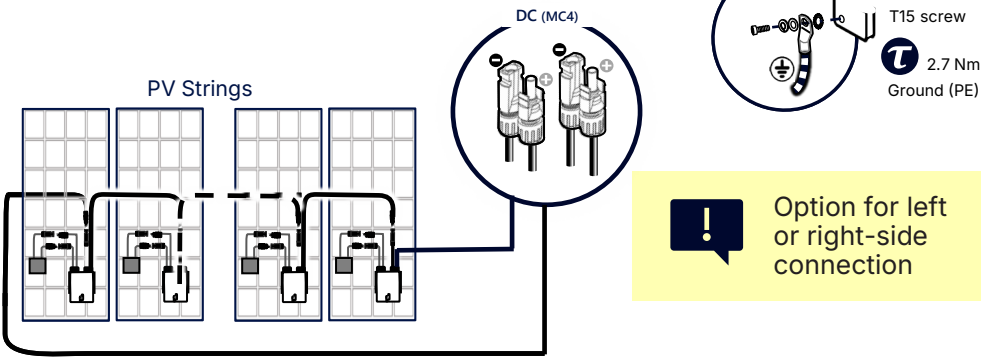

Wiring the inverter communications



The information in this guide is subject to change without notice. The system's final configuration, including the addition of communication termination resistors, is expected to be available in mid-2026. Until then, the system operates normally in its current configuration. While minor communication-related irregularities may occasionally occur, overall system performance is not affected and will be fully optimized once the final configuration is implemented.

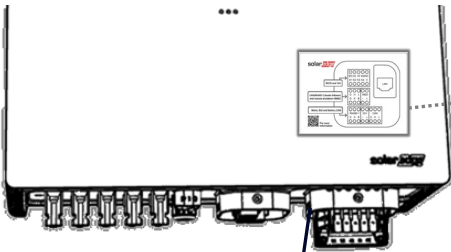

Label is found on the inverter below the decorative cover.

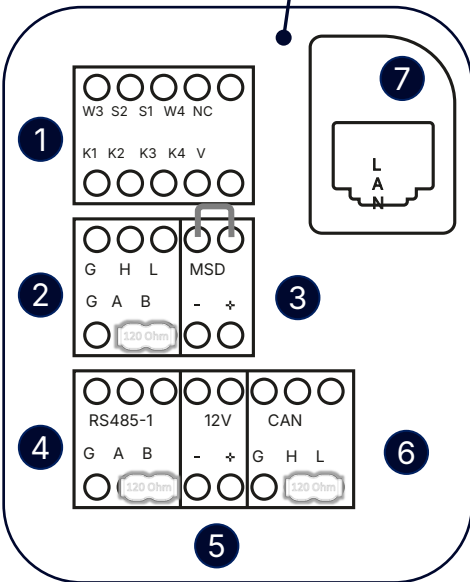

1. RRCR / 14a
2. CAN / RS485-2 (leader/follower)
3. Manual Shutdown (MSD)
4. Meter RS485-1
5. 12 V
6. CAN – Battery
7. LAN

 = termination resistor



The connector plugs are pre-connected to the inverter. Release the screws to remove the connectors.



Wiring the Meter RS485-1



To easily connect the communication cable, remove the two side screws and the connector, and after making the connections, reinsert the connector and tighten the screws.

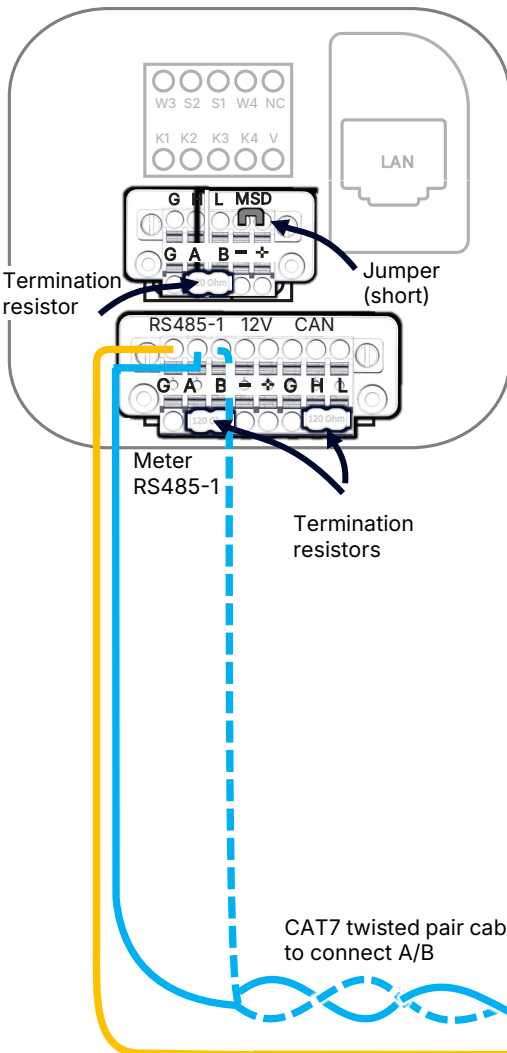

The SolarEdge Inline meter supports SolarEdge Home Network. The Nexis Inverter does **NOT** support SolarEdge Home Network. It will be supported in the future.

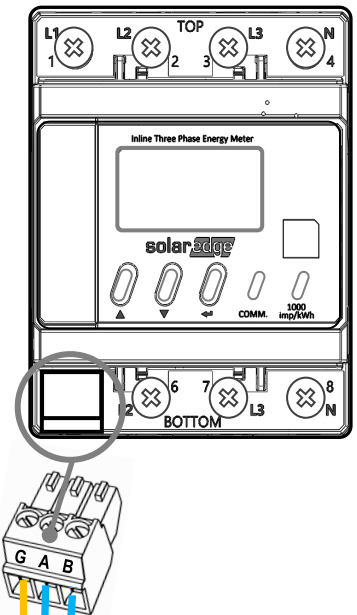

Wiring the LAN

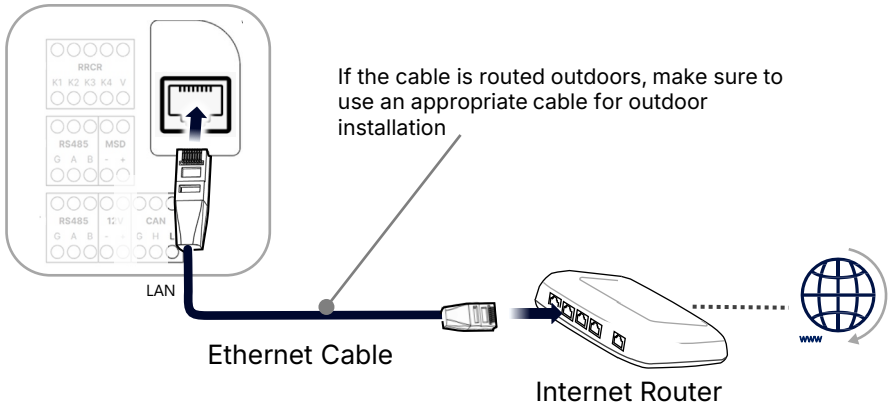

Wiring Radio Ripple Control Receiver (RRCR) / 14a Controller



Use minimum 5-wire cable (not supplied) with an external diameter of 5mm to ensure proper fit and sealing of the inverter gland.

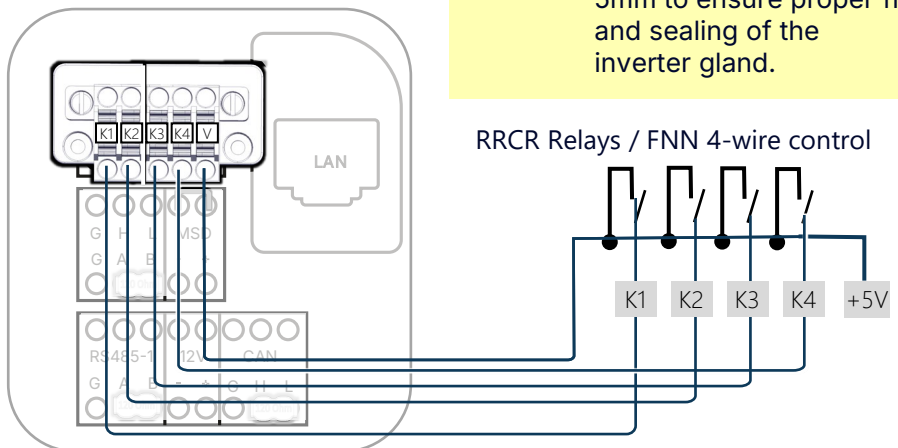

Wiring communications and 12 V power for the BUI

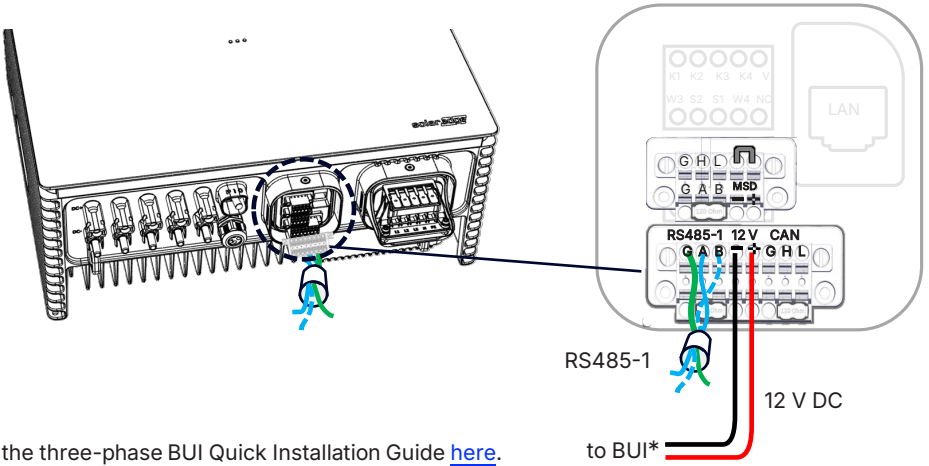

*See the three-phase BUI Quick Installation Guide [here](#).

Wiring communications from the Battery to the Inverter

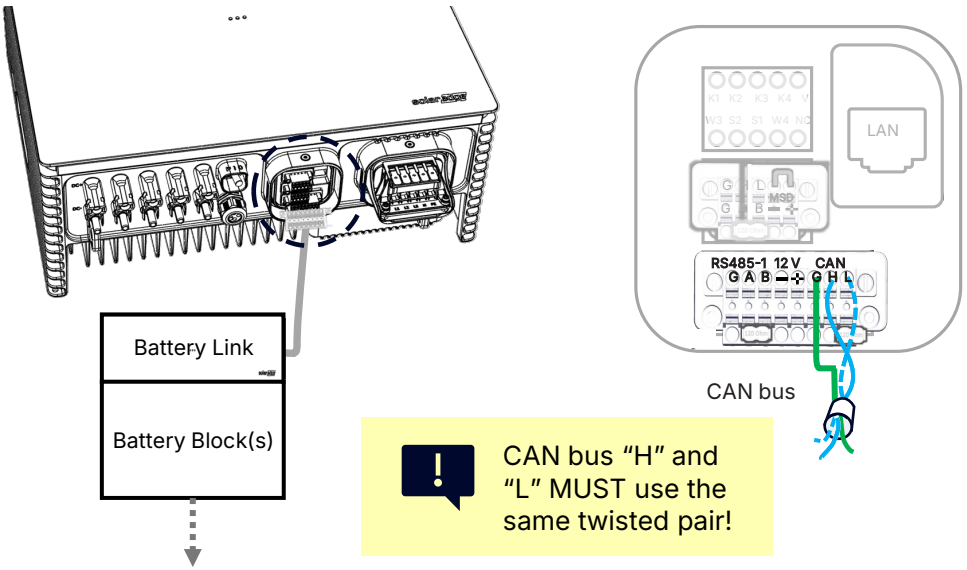

Wiring a Manual Shutdown switch to the inverter for Backup operation



Remove jumper when connecting the manual shut-down switch

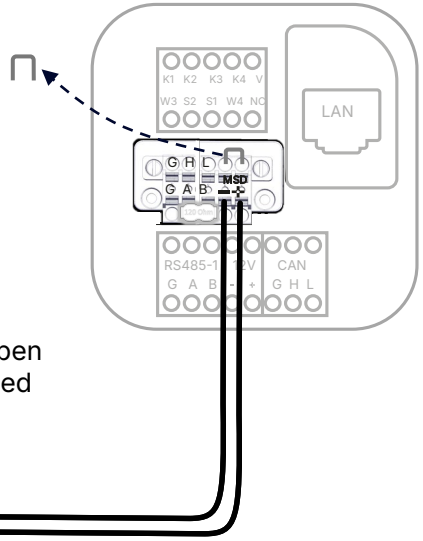

MSD switch (optional) – Use a Normally Closed (N.C) switch that latches in an open position when pressed, and when pressed again, returns to the closed position

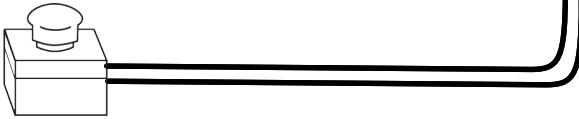

Refit the Comms cover cup

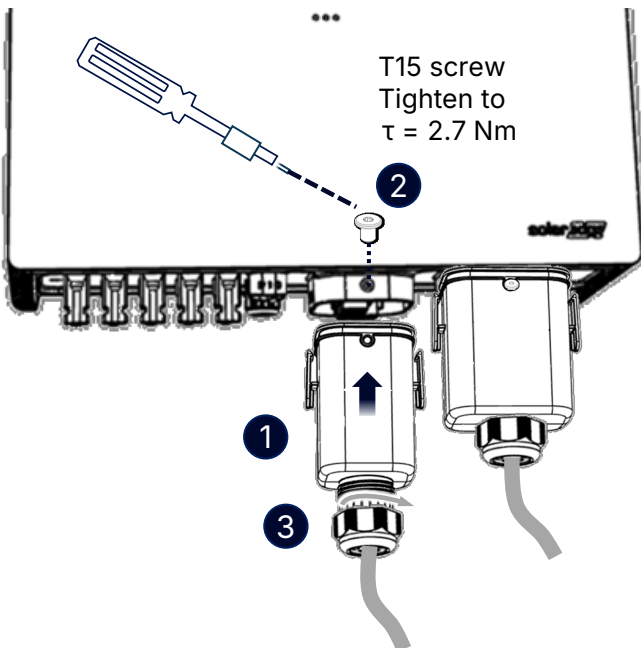

1a. Opening the Battery Package

1 Cut along the dashed lines

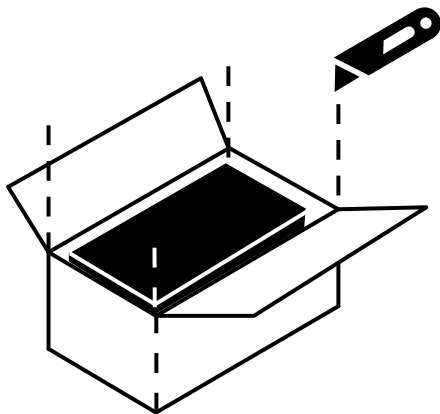

2 Use the package as your working surface

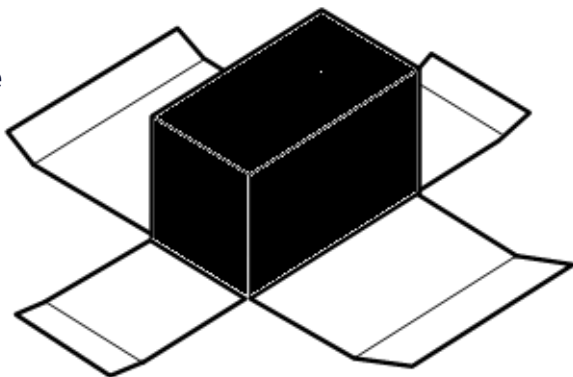

1b. Installing the Battery

Floor mount – Battery Block #1



Note that steps 1 to 4 must be executed without removing the Battery Block from its packaging

1 Attach the feet

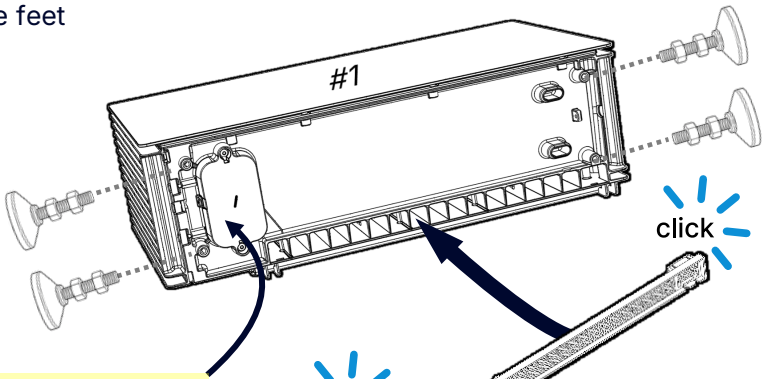

Do not remove the bottom cap cover



2 Attach the filter

3 Attach the handles

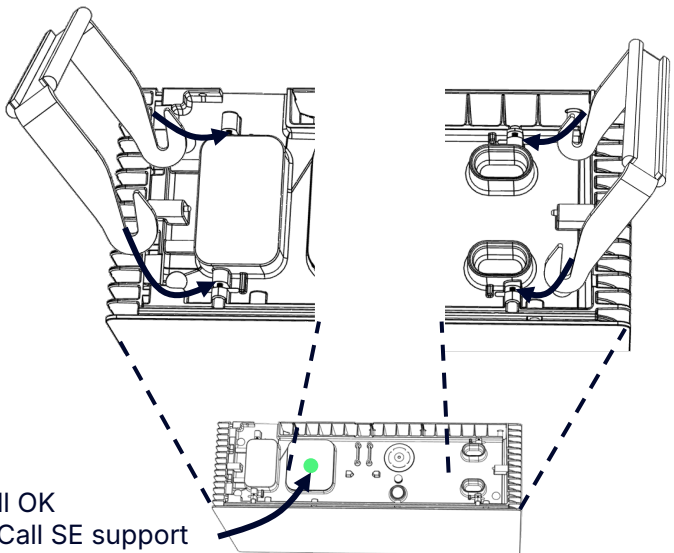

● Blinking LED – all OK
No LED – error! Call SE support



4 Use 2 people to lift the Battery Block onto its feet

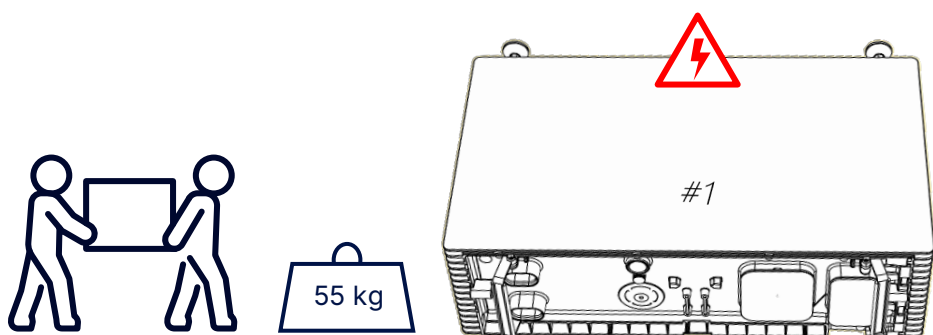

5 Level the first Battery Block by adjusting its feet - floor mount

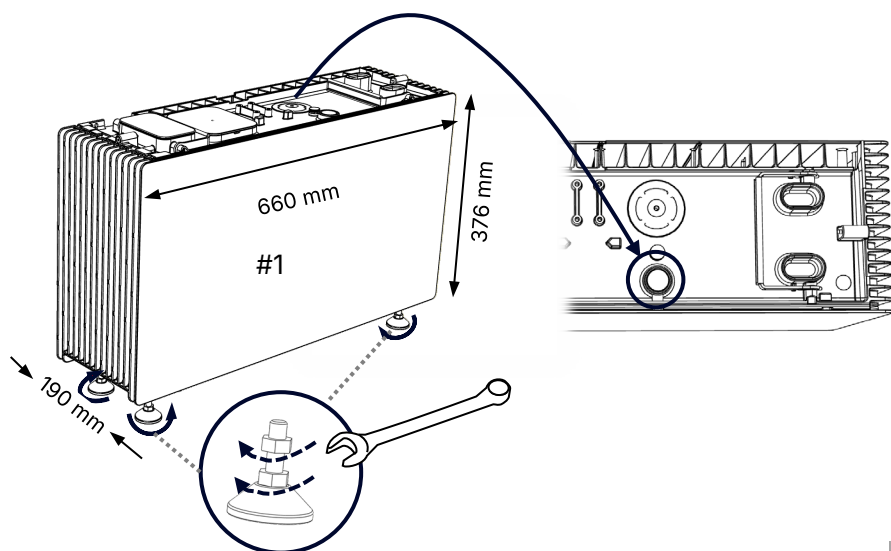

For floor mounting, use the tilt bracket to position the battery block correctly relative to the wall. Do not fix the bracket to the wall yet!

Check the minimum distance from the wall ("MIN. DIST. Line"):

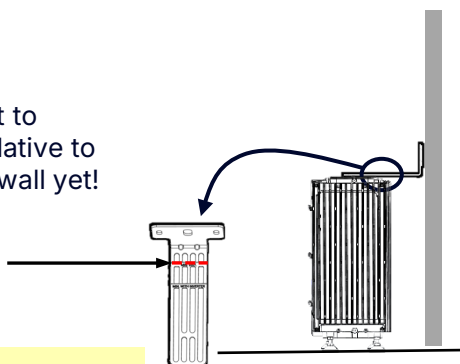

! 1,5 cm ≤ Distance from wall ≤ 10 cm



1c. Installing the Battery

Wall mount – Battery Block #1

1

Level the wall bracket and attach it to the wall

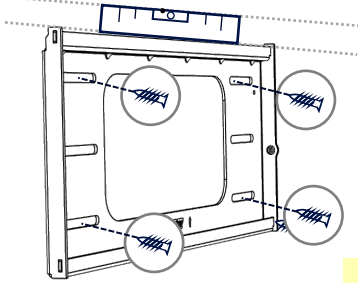

2

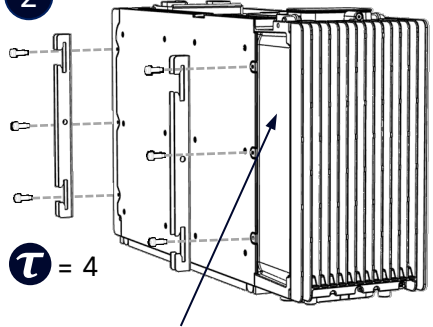

Take note of the OFFSET that these brackets cause to the position of the Battery Block when mounted on the wall.



Do not remove the bottom cap cover

3

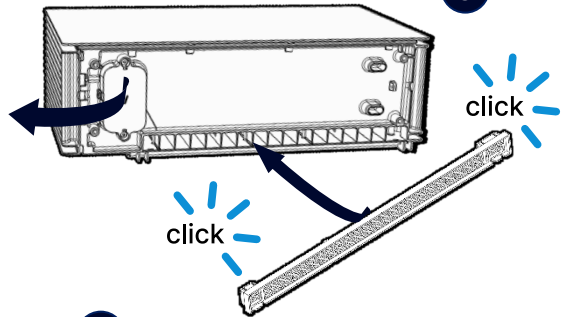

4

Hang the Battery Block on the wall bracket

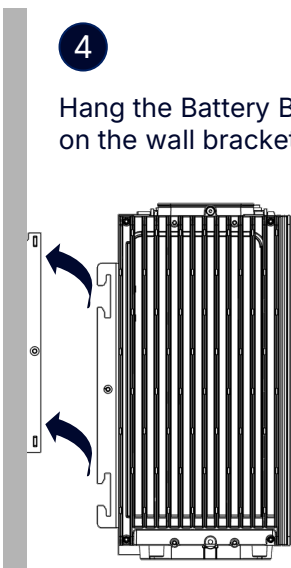

5

Fix the Battery Block to the wall bracket

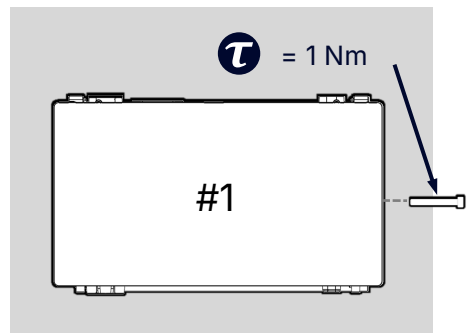

Building the battery – 1,2,3,or 4 Battery Blocks with Battery Link

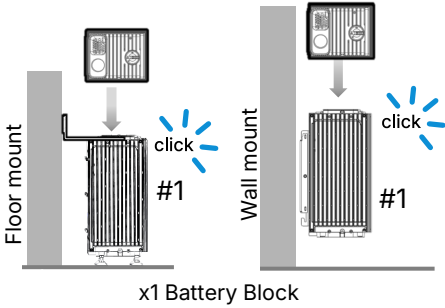

Don't forget to remove the red bottom quick connector caps on Battery Blocks #2, 3, 4 and Battery Link

Same process for Floor or Wall mount

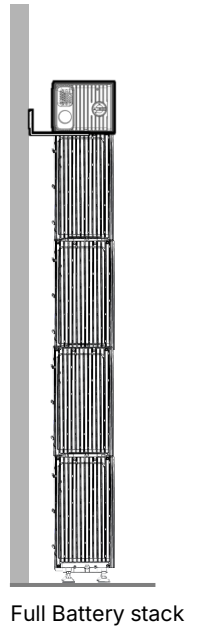
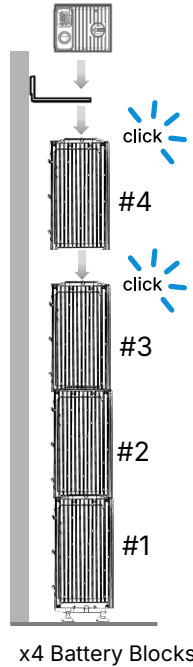
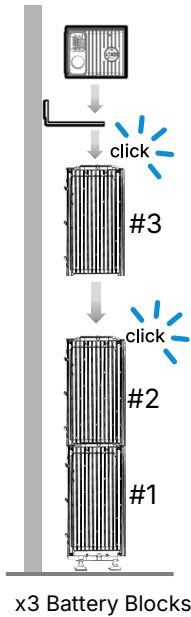
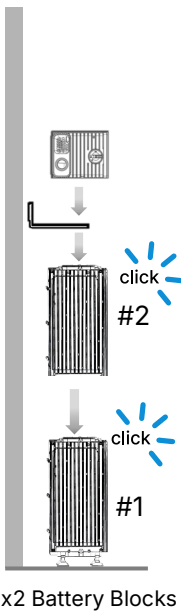

We recommend that the tilt bracket be installed either on top of the uppermost Battery Block OR on the one below the uppermost Block. It must NOT be installed on any of the lower-level Battery Blocks.



6 Position the wall bracket on top of the last or second-to-last Battery Block in the Battery Stack and mark the location of the holes for drilling into the wall.

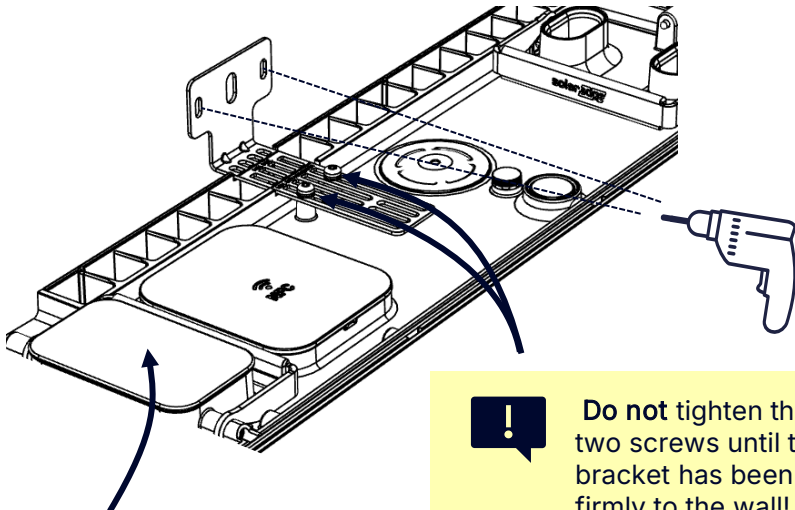

! Do not remove this cover until drilling is complete!

! Do not tighten these two screws until the bracket has been fixed firmly to the wall!

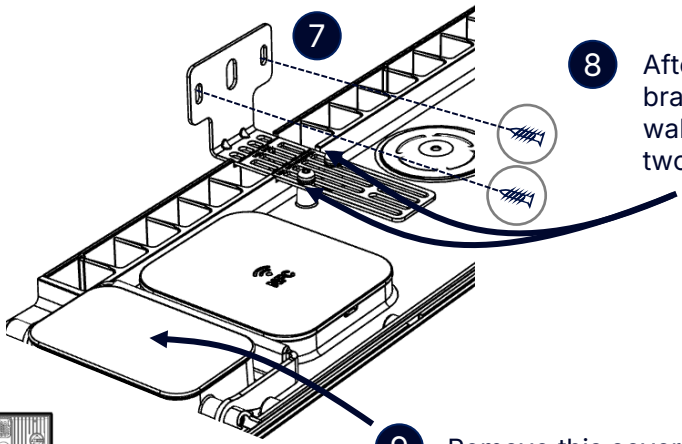

8 After fixing the wall bracket firmly to the wall, tighten these two screws.

9 Remove this cover!

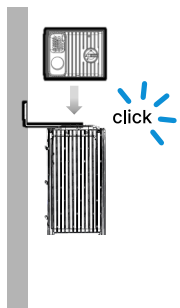

10 Attach the Battery Link to the top of the last Battery Block in the Stack.



Initial wiring steps

- 1 Turn OFF the AC circuit breaker and set the inverter P/1/0 switch to "0".
- 2 Turn OFF the Battery Link.

Opening the Battery Link

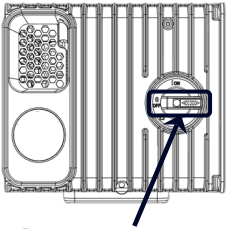

1 OFF



Wait 5 min
before open
the Battery Link

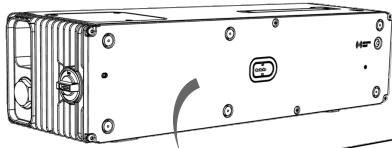

2

Decorative cover

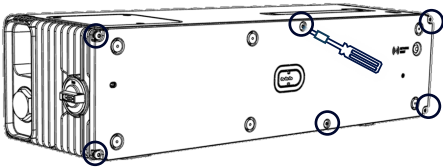

3 Release captive screws x6 (T25)

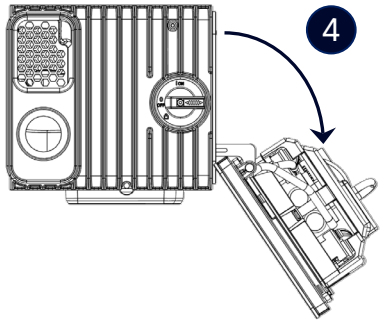

4



Wiring the Battery Link – left entry



DC and GND wire stripping lengths:

 19 mm

 12 mm

Ferrules are NOT mandatory.

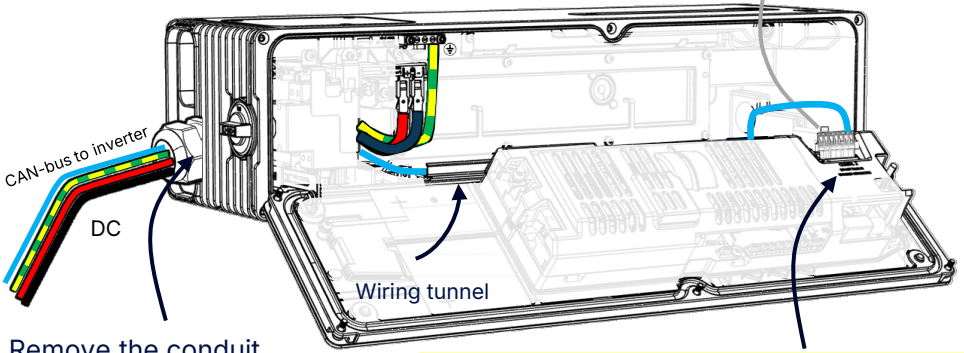
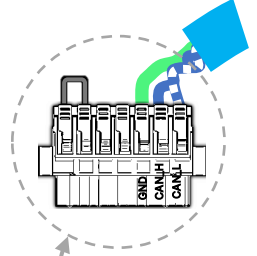

Remove the conduit entry plug and insert the supplied gland.



Do NOT insert an unwired plug into the comms connector!

Wiring the Battery Link – right entry

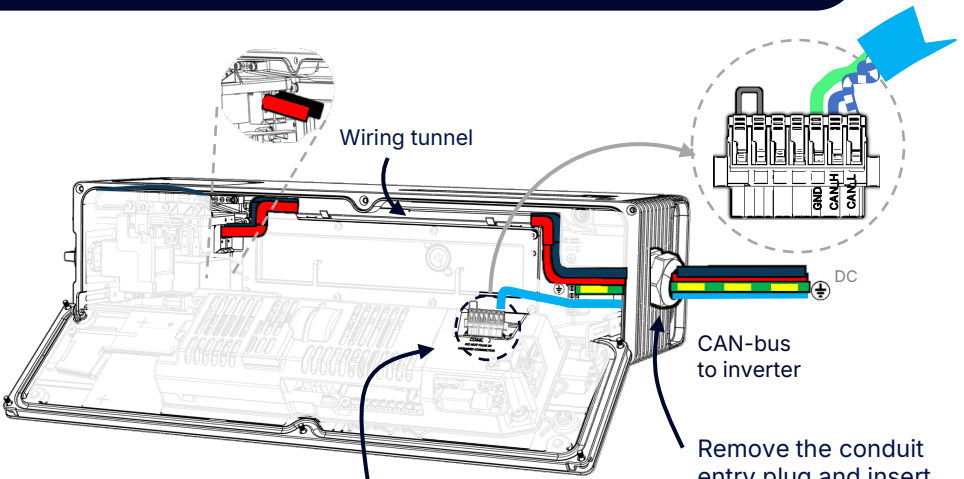

Do NOT insert an unwired plug into the comms connector!

Remove the conduit entry plug and insert the supplied gland.



GND bus bar screw tightening torque:

Wire gauge (mm ²)	Torque (Nm)
16 to 25	5
10	4,5
2,5 to 6	4

Wiring DC and communications from the Battery to the Inverter



- Connect PE/grounding cable as per [Wiring the Inverter DC](#)
- Wire the link communications as per [Wiring the Battery Link](#)
- Use any DC +/- input for the Battery DC

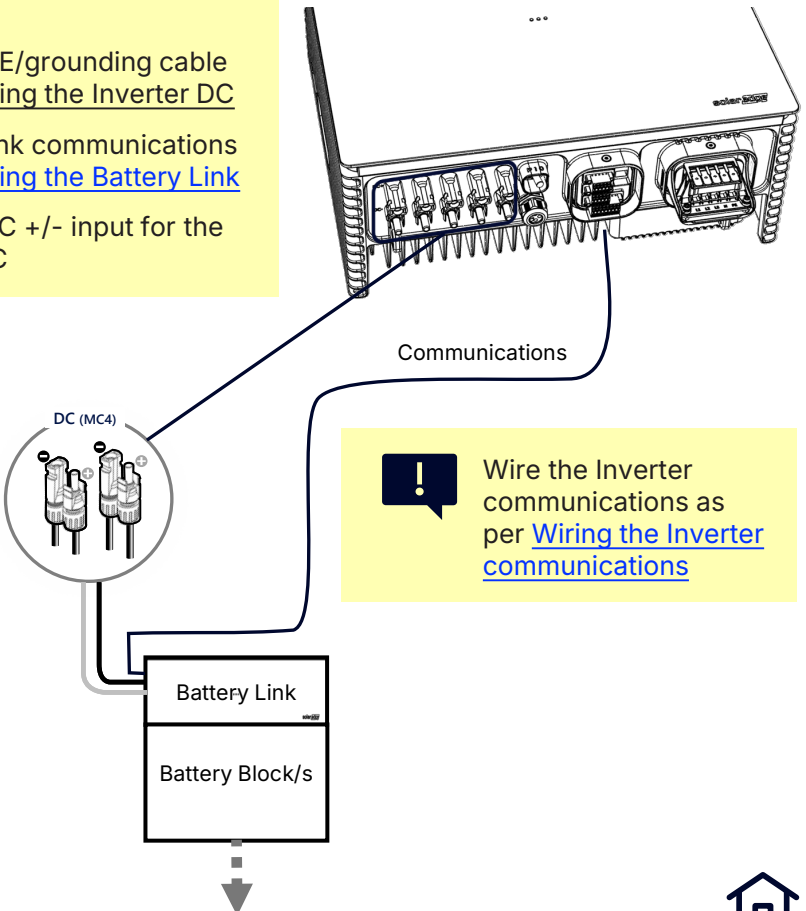

Wire the Inverter communications as per [Wiring the Inverter communications](#)



| 2. Power on the system

1 Battery Link

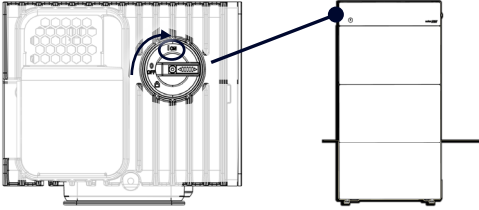

2 Electrical cabinet

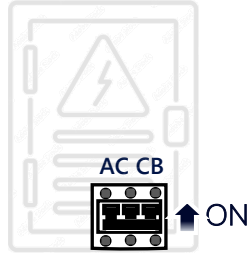

3 BUI



Set to "1"

4 Inverter

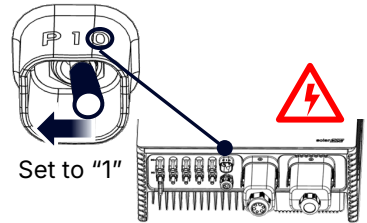

Set to "1"

| 3. Commissioning the inverter

1

Scan for SolarEdge GO

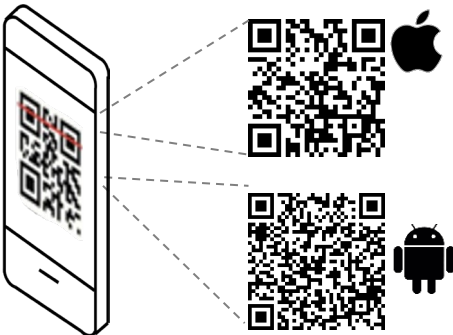

2

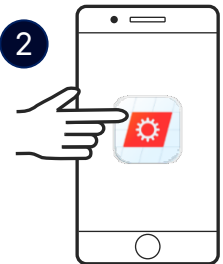

Run SolarEdge Go and follow the instructions on the screen



| 4. Led indicators

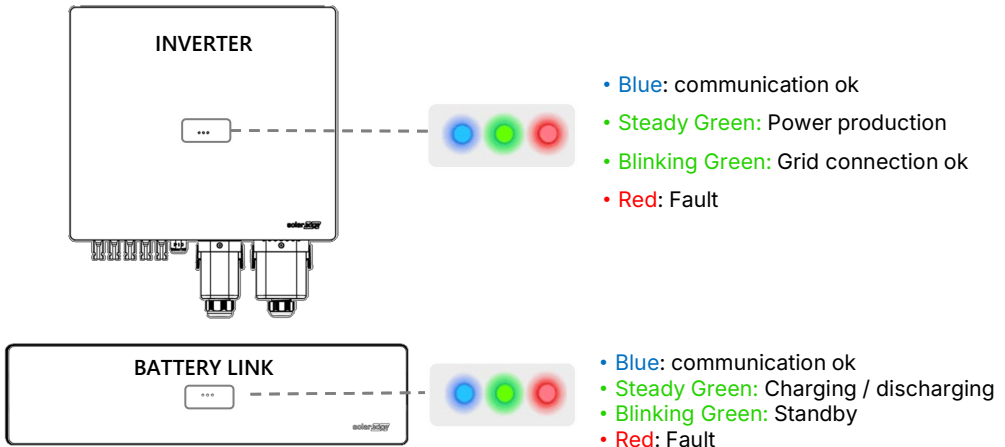

For more details, see [SolarEdge LEDs](#).

Backup interface and meter

For the complete description of the BUI LED AND Meter indicators, refer to the [BUI QIG](#).



Appendix 1

Partial Home Backup

