

Application Note – S0 Meter Cable Adapter Setup

Version History

- Version 1.2, September 2020
 - S0 meter connection options
 - Added SetApp configuration support
 - Added Monitoring functionality
 - Removed export limitation support

Contents

| | |
|--|----------|
| S0 Meter Cable Adapter Setup | 2 |
| Introduction | 2 |
| Connecting an S0 Meter to a Single Inverter System | 3 |
| Connecting an S0 Meter to a Multiple Inverter System | 3 |
| S0 Meter Installation..... | 4 |
| S0 Meter Configuration..... | 5 |
| Monitoring Data..... | 6 |

S0 Meter Cable Adapter Setup

Introduction

Meters with an S0 interface transmit energy measurements with pulses, using a dry contact relay. The pulses are then counted and represented as kWh values.

**NOTE**

Meters with S0 interfaces are relevant in the EU only.

The precision of the S0 interface may be lower than that of the RS485 interface, and as a result, their resolution and response time is undetermined. Also, in the event of a communication problem with the S0 meter, the total count will be lost.

S0 meters are *not* provided by SolarEdge. SolarEdge supports S0 meters that comply with the EN 62053-31 standard; this standard defines pulse duration (T_{on}) between 30mS and 120mS.

**NOTE**

When installing an S0 meter at the grid connection point (this location is supported by inverters with a display only), make sure that it counts the total positive energy, that is, the energy exported to the grid.

**NOTE**

S0 meters do not support export limitation functionality.

Connecting an S0 Meter to a Single Inverter System

When connecting an S0 interface meter in a single inverter system, the meter is connected to the inverter via an S0 meter adapter cable (available from SolarEdge).

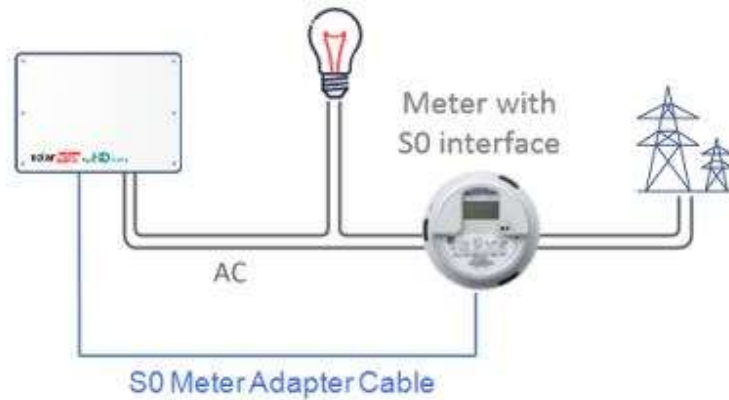

Connecting an S0 Meter to a Multiple Inverter System

When connecting an S0 interface meter in a multiple inverter system, the meter is connected to the inverter that serves as the Smart Energy Manager (or a Commercial Gateway) via an S0 meter adapter cable (available from SolarEdge).

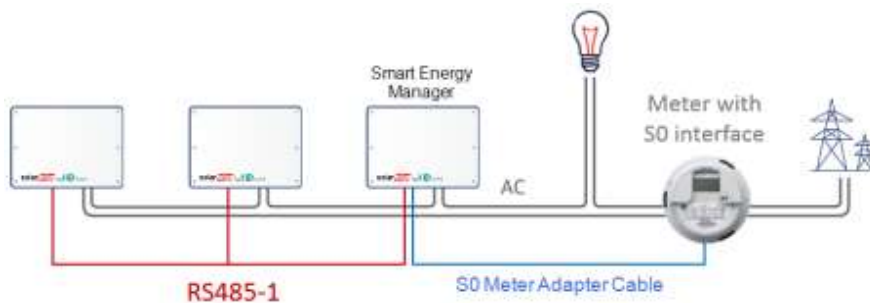

The S0 meter adapter cable has an 8-pin connector on one end, which connects to the inverter/CCG, and a 2-pin connector at the other end, which connects to a cable from the meter. The cable requirements are as follows:

- Minimum 2 wires (twisted pair). A CAT5 cable can be used.
- Wire cross section area: 0.2- 1 mm² / 24-18 AWG
- Cable outer diameter range: 2-4 mm / 0.08-0.16"
- Maximum length: 50 m / 164 ft

S0 Meter Installation

→ To connect the AC power to the meter:

For detailed information on how to install the meter and connect the AC side refer to the meter installation manual.

→ To connect the meter to the inverter:

1. Open the inverter cover as described in its manual.
2. Remove the seal from one of the openings in communication gland #2 at the bottom of the inverter and insert the wires from the meter through the opening.
3. Connect the wires from the meter cable to the 2-pin connector of the S0 adapter cable: Connect the Minus (-) wire to the S- pin and the Plus (+) to the S+ pin.
4. Check the S0 adapter cable connections for loose wires, and that S0+ and S0- are not crossed.
5. For inverters with a display: Connect the 8-pin connector of the S0 cable to the Power Reduction Interface connector on the inverter communication board.

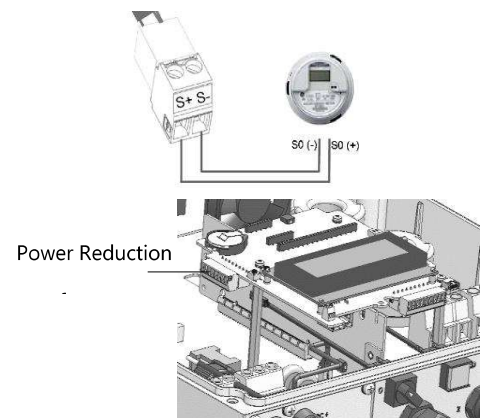
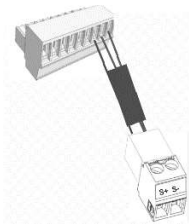

6. For inverters using SetApp: Connect the 8-pin connector of the S0 cable to the Power Reduction Interface connector on the inverter communication board. Insert the connector into the 8 leftmost sockets.

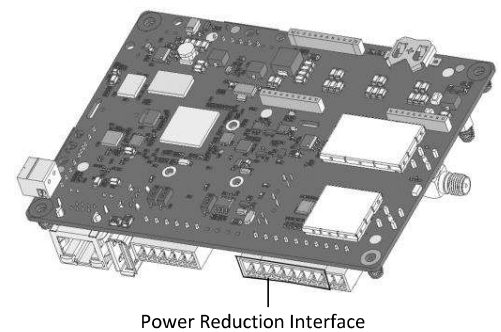

S0 Meter Configuration

Configuring the Inverter for S0 Meter Support using SetApp

→ To configure the inverter for S0 meter support using SetApp:



NOTE

Configuration of a SetApp inverter for S0 meter use is supported from version 4.10.16.

1. From the Commissioning page, select **Site Communication** → **GPIO** → **Device Type** → **S0 meter** to enable the S0 meter.
2. From the Commissioning page, select **Site Communication** → **GPIO** → **S0 meter** to access the S0 Meter page.
3. On the S0 Meter page, set the following parameters:
 - **S0 Function:** Consumption
 - **S0 Configuration:** set the number of pulses per kWh (default value is 1000)

→ To disable inverter support for the S0 meter using SetApp:

1. From the Commissioning page, select **Site Communication** → **GPIO** → **Device Type**, and select a device *other than* S0 Meter.

Configuring the Inverter for S0 Meter Support using the Device Display

→ To configure the inverter for S0 meter support using the device display:

1. Enter Setup mode, and select **Communication** → **GPIO Conf** → **S0 meter** to configure GPIO to work with the S0 meter.
2. Select **Device Type** → **S0 meter** → **S0 conf** → **Meter Func**, and select either **Export** or **Consumption** according to the actual meter location/measurement:

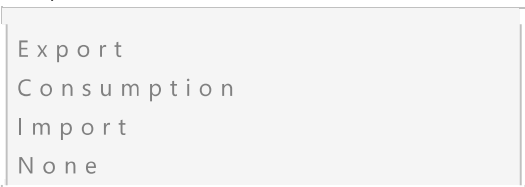

- **Export:** The meter is installed at the grid connection point and reads the energy fed into the grid
- **Consumption:** The meter is installed at the load consumption point and reads the energy consumed by the site
- **Import:** The meter is installed at the grid connection point and reads the energy purchased from the grid
- **None:** No reading

The selected option is displayed in the S0 Conf screen as either <Feed>, <Cons>, <Prce>, or <None>.

5. Select **Device Type** → **S0 meter** → **S0 conf** → **PLS per kWh**, and enter a value between 250 and 10000 for the number of pulses per kWh reading, according to the installed meter’s specification.
6. Exit the Setup mode.

Monitoring Data

If your device is connected to the SolarEdge server, you can view the S0 meter's readings in the monitoring platform.

The data from the inverters and from installed meters is displayed in the Dashboard and Charts tabs of the monitoring platform. The displayed data depends on the meter(s) location: grid connection point (export), or load consumption point (consumption). The following tables detail the displayed information per meter location.

No meter installed:

| Data | Displayed in Monitoring Dashboard | Displayed in Monitoring Charts |
|----------------------------|-----------------------------------|--------------------------------|
| Production (inverter/site) | ✓ | ✓ |
| Consumption | X | X |
| Self-consumption | X | X |
| Export | X | X |
| Import | X | X |

Export meter:

| Data | Displayed in Monitoring Dashboard | Displayed in Monitoring Charts |
|---------------------------|-----------------------------------|--------------------------------|
| Production(inverter/site) | ✓ | ✓ |
| Consumption | X | X |
| Self-consumption | ✓ (calculated) | ✓ (calculated) |
| Export | X | ✓ |
| Import | X | X |

Consumption meter:

| Data | Displayed in Monitoring Dashboard | Displayed in Monitoring Charts |
|----------------------------|-----------------------------------|--------------------------------|
| Production (inverter/site) | ✓ | ✓ |
| Consumption | ✓ | ✓ |
| Self-consumption | ✓ (calculated) | ✓ (calculated) |
| Export | X | ✓ (calculated) |
| Import | X | X |