

Sigen EV DC Charging Module

User Manual



Sigen EV DC Charging Module User Manual

SigenStor EVDC 12 (5S2, 7.5S2, 10S2, 7.5GBT, 10GBT)
SigenStor EVDC 25 (5S2, 7.5S2, 10S2, 7.5GBT, 10GBT)

Version: 04
Release date: 2025-06-13



Copyright Notice

Copyright© 2025 Sigenergy Technology Co., Ltd. All Rights Reserved.

Description in this document may contain predictive statements regarding financial and operating results, product portfolio, new technology, configurations and features of product. Several factors could cause difference between actual results and those expressed or implied in the predictive statements. Therefore, description in this document is provided for reference purpose only and constitutes neither an offer nor an acceptance. Sigenergy Technology Co., Ltd. may change the information at any time without notice.



SIGENERGY and other Sigenergy trademarks are owned by Sigenergy Technology Co., Ltd.

All trademarks and registered trademarks in this document belong to their owners.



Website



LinkedIn



YouTube

www.sigenergy.com

Revision History

Version	Date	Description
04	2025.06.13	<p>Added Scheduled Charging.</p> <p>Updated Charging Mode Settings.</p> <p>Added Scheduled Charging.</p> <p>Updated Charging Mode Settings.</p>
03	2025.01.06	<p>Updated Typical System Wiring.</p> <p>Added Charging Power Allowed for EVDC Settings.</p> <p>Added Charging Mode Settings.</p> <p>Added OCPP Settings.</p> <p>Added Charging Power Allowed for EVDC Settings.</p> <p>Added Charging Mode Settings.</p> <p>Added OCPP Settings.</p>
02	2024.12.06	<p>Updated Model Designation.</p> <p>Updated Location Requirements.</p> <p>Updated LED Indicator Status.</p> <p>Updated Stop Charging.</p> <p>Updated Stop Charging.</p>
01	2024.06.20	First official release.

Overview

Introduction

This document mainly describes product information, networking, and system operation and maintenance of SigenStor EVDC 12 (5S2, 7.5S2, 10S2, 7.5GBT, 10GBT) and SigenStor EVDC 25 (5S2, 7.5S2, 10S2, 7.5GBT, 10GBT) (hereafter referred to as SigenStor EVDC).

Readers

This document is suitable for product users and professionals.

Sign Definition

The following signs may be used in the document to indicate security precautions or key information. Before installation, operation, and maintenance of the equipment, familiarize yourself with signs and their definitions.

Signs	Definition
 Danger	Danger. Failure to comply will result in death or serious personal injury.
 Warning	Warning. Failure to comply will result in serious personal injury or property damage.
 Caution	Caution. Failure to comply will result in property damage.



Safety Precautions

Basic Information

Before installation, operation, and maintenance of the equipment, familiarize yourself with this document.

The "Danger", "Warning", "Caution" items described in this manual are only supplementary to all precautions.

The Company shall not be liable for equipment damage or property loss caused by the following reasons:

- Failure to obtain approval from the national, regional power authority.
- The installation environment does not meet international, national, or regional standards.
- Failure to observe local laws, regulations and norms when operating and maintaining equipment.
- The installation area does not meet the requirements of the equipment.
- Failure to follow the instructions and precautions in this document.
- Failure to follow the warning labels on equipment or tools.
- Negligent, improper operation or intentional damage.
- Damage caused by your or a third party's replacement of our equipment.
- The equipment is damaged because the your or a third-party company fails to use the accessories supplied with the packing box or purchase and install accessories of the same specification.
- Equipment damage caused by improper operations such as disassembling, replacing, or modifying the software code without authorization.
- Equipment damage caused by force majeure (such as war, earthquake, fire, storm, lightning, flood, debris flow, etc.).
- Damage caused by the failure of the natural environment or external power parameters to meet the standard requirements of the equipment during

actual operation (for example, the actual operating temperature of the equipment is too high or too low).

- The equipment was stolen.
- The equipment is damaged after the warranty period.

Safety Requirements

Danger

- Do not expose the equipment to high temperature or heat sources, such as ignition sources, heaters, etc.
- Do not clean or soak the equipment with water, alcohol, or oil to avoid power leakage or battery pack leakage.
- Do not leave liquid in the charging connector or socket.
- Do not knock or impact the equipment. In case of an accident, please stop using the equipment immediately and contact your installer or sales agent, The equipment shall be inspected and evaluated by professional personnel before continuing to use.
- Do not use the equipment in bad weather, such as heavy rain or snowstorm, when installed outdoors.
- Do not extend sharp objects or fingers into the equipment.

Warning

- The heat sink is hot when the equipment is operating. Do not touch it.
- Do not drop the charging connector.
- Please put the charging connector and charging cable in the designated location and avoid contamination or moisture on the charging connector or damage to the charging connector cable due to crushing by heavy loads such as vehicles.

Caution

- Do not use the equipment with faults. If the equipment appears abnormal, contact your installer or sales agent.
- Do not connect cables or adapters that are not required for installing this equipment.
- Do not use the equipment for any purposes other than vehicle charging.
- Do not use a private generator as the power source for the equipment.
- Do not forcedly bend or knock components on the equipment.
- Carbon dioxide fire extinguishers or ABC dry powder fire extinguishers are recommended at home.
- If the equipment cannot be charged, please contact your installer or sales agent in time.
- The radio waves generated when using the equipment may affect the normal use of implantable medical devices or personal medical devices, such as pacemakers, implantable defibrillators, hearing AIDS, etc. Consult with your medical device manufacturer about the restrictions of using the equipment before use.

Do not use the equipment in the following situations:

- When connected to public infrastructure systems.
- When connected to emergency medical equipment.
- When connected to elevators and other control devices.
- Any other critical systems.

Product Introduction

Model Designation

SigenStor EVDC includes the following models:

- SigenStor EVDC 12 5S2
- SigenStor EVDC 12 7.5S2
- SigenStor EVDC 12 10S2
- SigenStor EVDC 25 5S2
- SigenStor EVDC 25 7.5S2
- SigenStor EVDC 25 10S2
- SigenStor EVDC 12 7.5GBT
- SigenStor EVDC 12 10GBT
- SigenStor EVDC 25 7.5GBT
- SigenStor EVDC 25 10GBT

Fig Model designation (example)

SigenStor EVDC 12 5S2

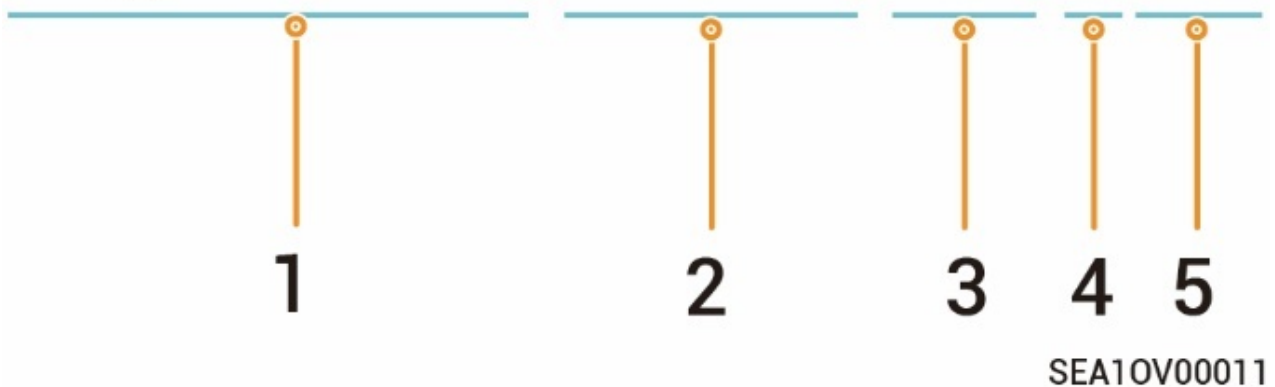

S/N	Definitions	Description
1	Product series	SigenStor 5-in-One system
2	Charger type	EVDC: DC charger
		<ul style="list-style-type: none"> • 12: 12.5 kW

3	Rated output power	<ul style="list-style-type: none">● 25: 25 kW
4	Length of charging connector cable	<ul style="list-style-type: none">● 5: 5 m● 7.5: 7.5 m● 10: 10 m
5	Connector type	<ul style="list-style-type: none">● S2: CCS2, that is CCS Combo2, a European standard DC charging connector● GBT: GBT2015 national standard DC charging port

Description

SigenStor EVDC is a bidirectional DC/DC charging & discharging system and can be used with our SigenStor EC, SigenStor AC, and Sigen Hybrid series, as well as battery pack SigenStor BAT to charge and discharge power batteries of electric vehicles.

Product Appearance

SigenStor EVDC 12 (5S2, 7.5S2, 10S2), SigenStor EVDC 25 (5S2, 7.5S2, 10S2)

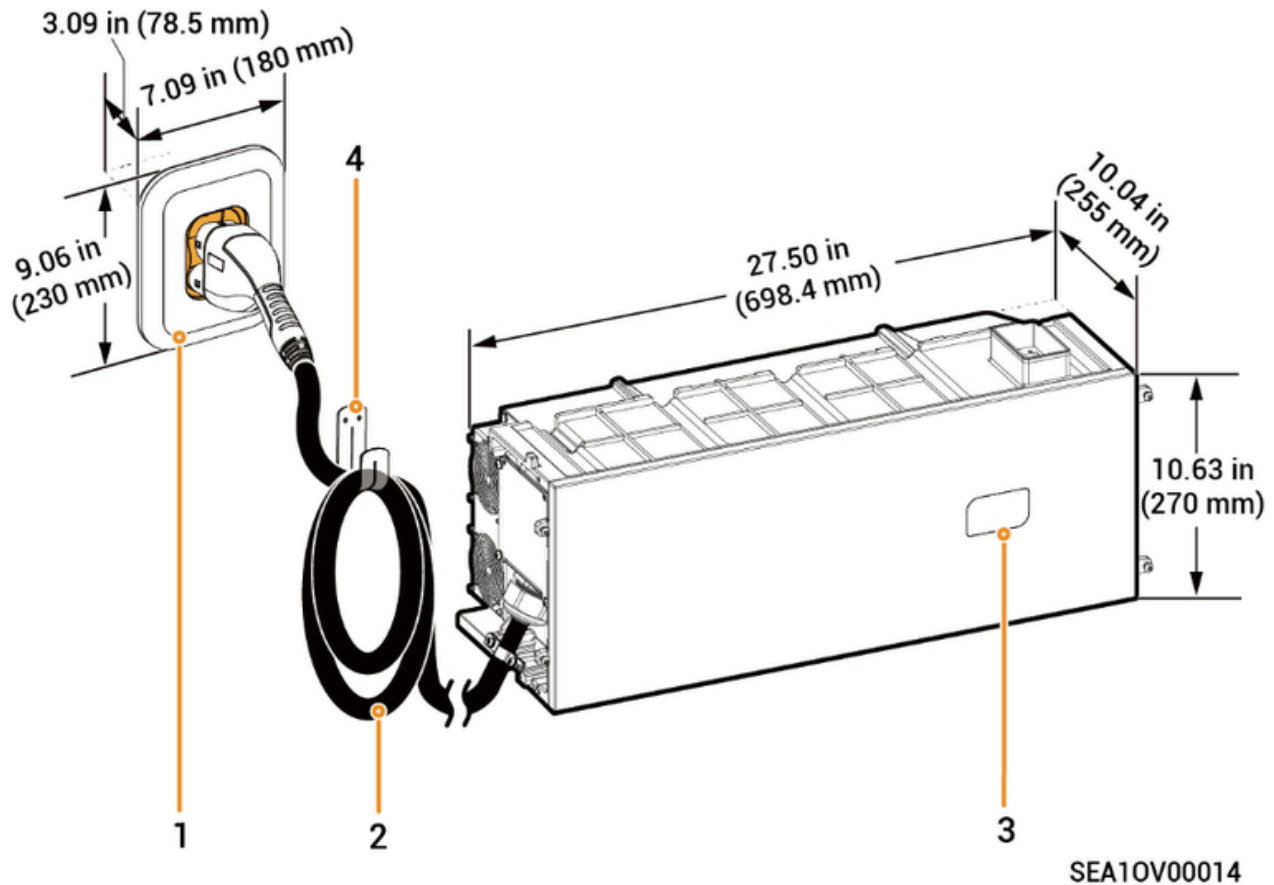

S/N	Description
1	Charging connector holder for placing the charging connector
2	Charging connector cable
3	RFID card reading area
4	Cable holder for storing the charging cable

SigenStor EVDC 12 (7.5GBT, 10GBT), SigenStor EVDC 25 (7.5GBT, 10GBT)

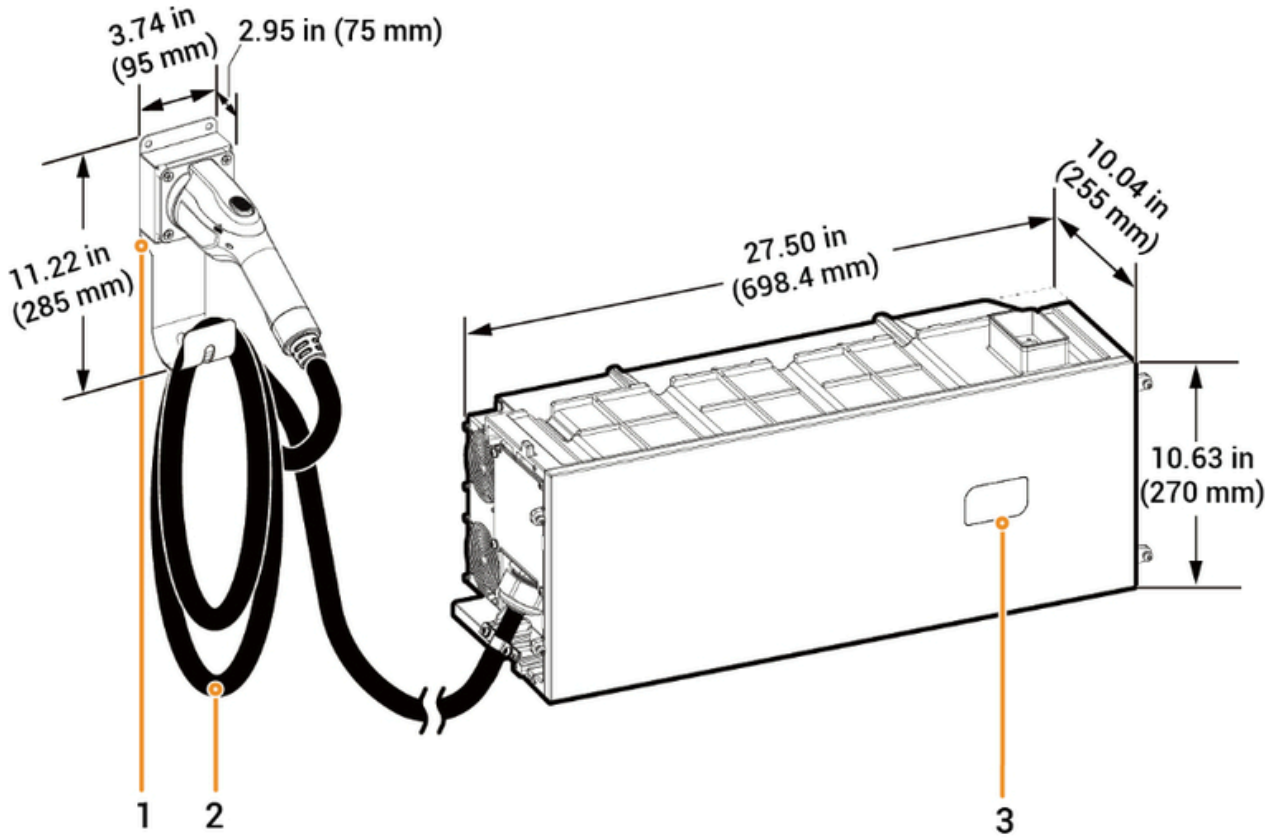

SEA10V00014

S/N	Description
1	Charging connector holder for placing the charging connector
2	Charging connector cable
3	RFID card reading area

Label Description

Symbol	Definitions
	<p>Danger! High Voltage</p> <p>High voltage exists inside the equipment when powered on. Do not open the casing when the equipment is running. Any maintenance or servicing operations must be performed by trained and skilled electrical engineers.</p>
	<p>Warning! Life at risk.</p> <p>The equipment has potential hazards after running. Take proper protection when operating the equipment.</p>
	<p>After the equipment is powered off, the discharge of internal components is delayed. Wait 10 minutes until the equipment is fully discharged according to the label time.</p>
	<p>Warning! Risk of burns.</p> <p>The surface of the heat dissipation area is hot when the equipment is running. Do not touch it to avoid burns.</p>
	<p>Please refer to the instructions to operate the equipment.</p>
	<p>Earthing mark</p>

Typical System Wiring

(PV) Storage and Charging System Wiring

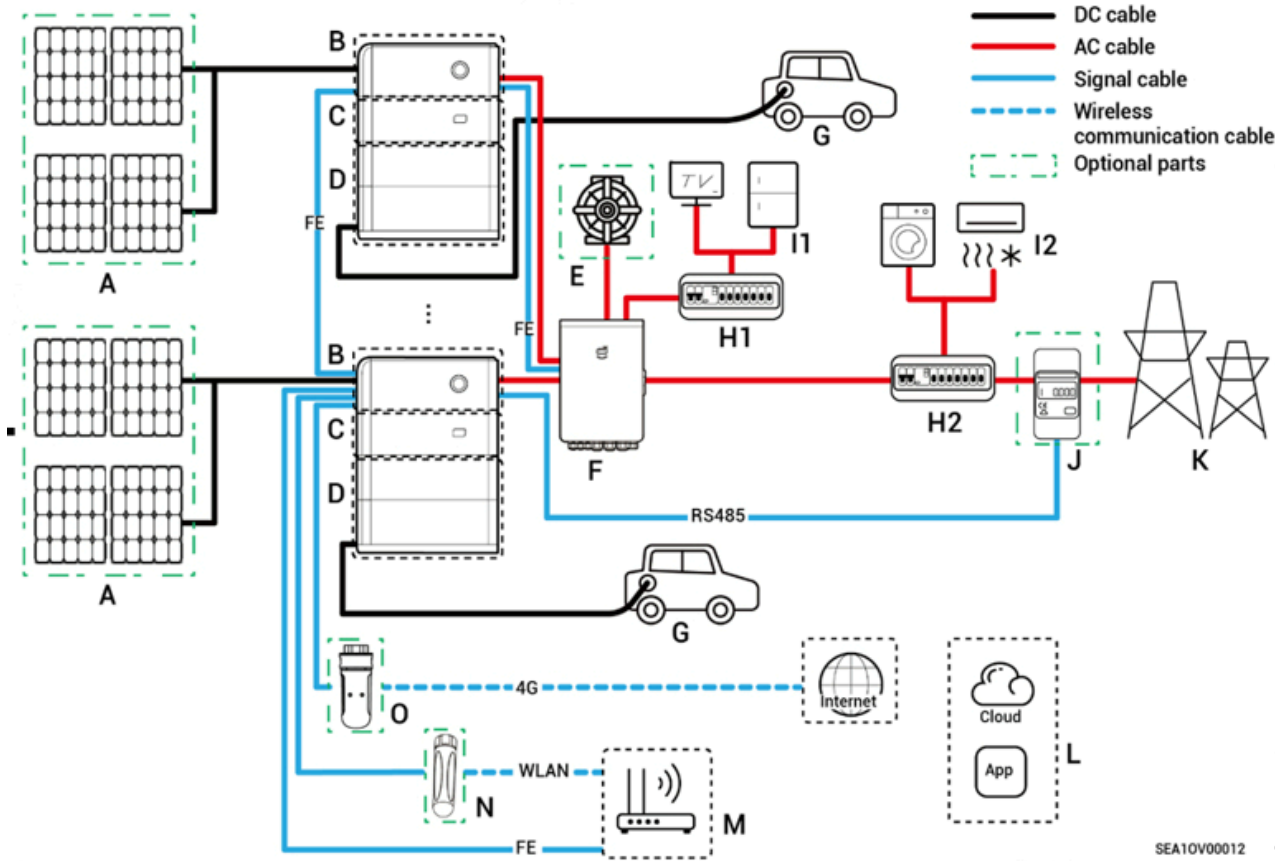

SEA10V00012

No.	Description	No.	Description	No.	Description
A	Solar Panel	B	SigenStor EC/ Sigen Hybrid	C	SigenStor EVDC
D	SigenStor BAT	E	Diesel Generator	F	Gateway
G	Vehicle	H1	Backup Power Distribution Panel	H2	Non-backup Power Distribution Panel
			Non-backup		

I1	Backup Power Equipment	I2	Power Equipment	J	Power Sensor
K	Power Grid	L	mySigen	M	Router
N	Antenna	O	CommMod		

Tips

- J features data collection from grid-connected points to realize zero power grid connection. For partial backup, J can be left un-configured. In the case of partial backup + zero-power grid connection control, J is configured.
- As a backup energy source for long-term off-grid applications, the diesel generator can work in tandem with the Gateway to provide a smooth transition between PV, energy storage, and diesel power generation.
- If H2 (Non-backup Power Distribution Panel) features leakage protection, it is recommended that the rated residual operating current be greater than or equal to the number of inverters × 100 mA.
- If I1 (Backup Power Equipment) experiences leakage, it may pose a risk of electric shock. In order to avoid this hazard, a residual current device (RCD) must be installed between the F (Gateway) and the I1 (Backup Power Equipment).
- It is recommended to use Fast Ethernet and WLAN for communication with inverters. When free 4G traffic of Sigen CommMod runs out, users must top up their accounts or replace an SIM card.

PV and Charging System Wiring

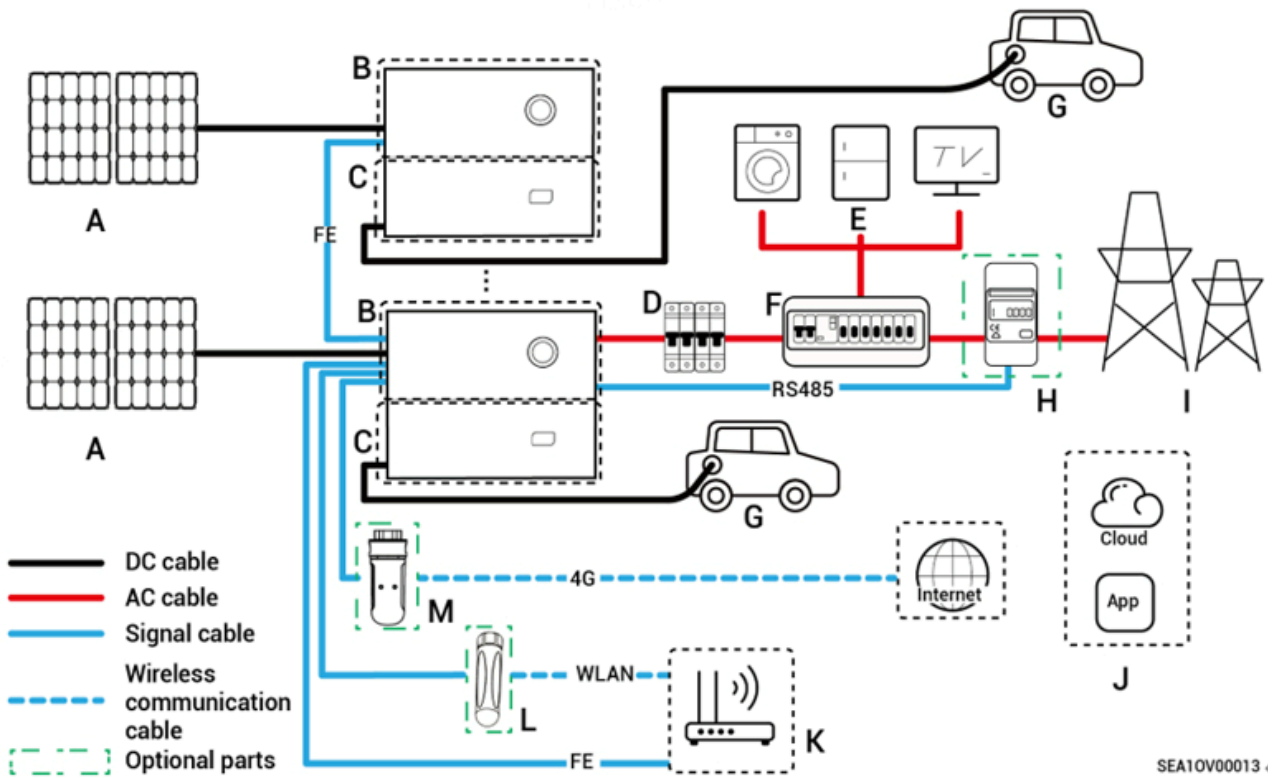

No.	Description	No.	Description	No.	Description
A	Solar Panel	B	Sigen Hybrid	C	SigenStor EVDC
D	AC switch	E	Power Equipment	F	Distribution Panel
G	Vehicle	H	Power Sensor	I	Power Grid
J	mySigen	K	Router	L	Antenna
M	CommMod				

Tips

- If F (Distribution Panel) features leakage protection, it is recommended that the rated residual operating current be greater than or equal to the number of inverters × 100 mA.
- It is recommended to use Fast Ethernet and WLAN for communication with inverters. When free 4G traffic of Sigen CommMod runs out, users must top up their accounts or replace an SIM card.

Location Requirements

Tips

- Before installing the equipment, please be sure to carefully read the following installation requirements. The company will not be liable for any functional abnormalities or damages arising from the operation of the equipment if the installation requirements are not followed, even in cases leading to personal safety incidents.
- During actual installation, the selection of installation location should comply with local firefighting, environmental protection regulations, and other relevant laws. The specific installation location planning should be subject to the installer or engineering, procurement, and construction (EPC) contracts.

Installation Environment Requirements

- Do not install the equipment in smoky, flammable, or explosive environment.
- Avoid exposing the equipment to direct sunlight, rain, standing water, snow, or dust. It is suggested to install the equipment in a sheltered place. Take preventive measures in operating areas prone to natural disasters such as floods, mudslides, earthquakes, and typhoons.
- Do not install the equipment in an environment with strong electromagnetic interference.
- The temperature and humidity of the installation environment should meet equipment requirements.
- The equipment should be installed in an area that is at least 1640.42 ft (500 m) away from corrosion sources that may result in salt damage or acid damage. Corrosion sources include but are not limited to seaside, thermal power plants, chemical plants, smelters, coal plants, rubber plants, and electroplating plants.
- In areas with good marine environments (such as Norway, where the nearshore salinity is ≤ 28 psu), the mounting distance of the device from the coastline can be appropriately relaxed to ≥ 656.17 ft (200 m).

- If the outer surface of the device is damaged, please repaint the device in time.

Installation Position Requirements

- Do not tilt the equipment or place it upside down. Ensure that the equipment is horizontally installed.
- Do not install the equipment in places easily touched by children.
- Do not install the equipment in a place with fire hazards or is prone to moisturizing.
- The equipment produces sound when it is operating. Please install the equipment in a place with appropriate distance at which there is no impact to daily work and life.
- Do not install the equipment in a sealed, poorly ventilated location without fire protection measures and inaccessible for firefighters.
- The equipment is hot when it is operating. If the equipment is installed indoors, please ensure good indoor ventilation and avoid significant indoor temperature rise by more than 37.4°F (3°C) while the equipment is operating. Otherwise, the equipment will be derated.
- Do not install the equipment in mobile scenarios such as recreational vehicles, cruise ships, and trains.
- It is recommended to install the equipment in a location where you can easily access, install, operate, and maintain it, and view the indicator status.
- Do not place the equipment in the vehicle passage when installed in a garage to avoid collisions.
- Install the equipment near the parking space. Refer to the figure for the installation distance.

Mounting surface

- Do not install the equipment on a flammable base. If this cannot be avoided, add a fire barrier between the equipment and the flammable base.

- The installation base should meet the load-bearing requirement. Solid brick-concrete structures, concrete walls, and floors are recommended.
- The installation base should be flat, and the installation area should meet the installation space requirements.
- No plumbing or electrical alignments are allowed inside the installation base to avoid potential drilling hazards during equipment installation.

SigenStor EVDC can only be installed underneath the inverter.

Relative humidity
5% to 95%RH

Ambient temperature
-22°F to 140°F
(-30°C to 60°C)

Heat source
(140°F/60°C)
distance

IP66

SEA1SF00002

Model	R (ft)	R (m)
SigenStor EVDC 12 5S2, SigenStor EVDC 25 5S2	15.91	4.85
SigenStor EVDC 12 (7.5S2, 7.5GBT)	24.11	7.35
SigenStor EVDC 25 (7.5S2, 7.5GBT)	24.11	7.35
SigenStor EVDC 12 (10S2, 10GBT)	32.32	9.85
SigenStor EVDC 25 (10S2, 10GBT)	32.32	9.85

Model	R (ft)	R (m)
SigenStor EVDC 12 5S2, SigenStor EVDC 25 5S2	$=16.4 - N \times 0.958$	$=5 - N \times 0.292$
SigenStor EVDC 12 (7.5S2, 7.5GBT)	$=24.61 - N \times 0.958$	$=7.5 - N \times 0.292$
SigenStor EVDC 25 (7.5S2, 7.5GBT)	$=24.61 - N \times 0.958$	$=7.5 - N \times 0.292$
SigenStor EVDC 12 (10S2, 10GBT)	$=32.81 - N \times 0.958$	$=10 - N \times 0.292$
SigenStor EVDC 25 (10S2, 10GBT)	$=32.81 - N \times 0.958$	$=10 - N \times 0.292$

Tips

There will be errors in the actual distance under different installation environments, and the figure is for reference only.

Equipment Installation and Connection







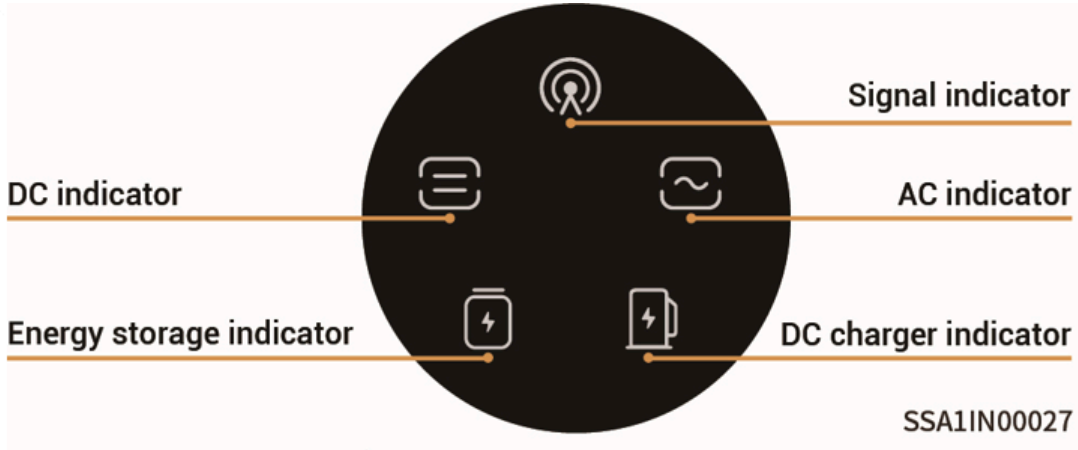

Equipment installation and connection must only be completed by the installer certified by the Company. For more information, refer to ***Sigen EV DC Charging Module Installation Guide***.

How to Use

LED Indicator Status

The status of SigenStor EVDC is indicated by the DC charger indicator on the front of the inverter.



Indicator	Color	Status	Status of SigenStor EVDC
		Off	Not powered on.
		Steady on	Powered on but the charging connector not connected to the vehicle.
		Steady on	<ul style="list-style-type: none"> The charging connector connected to the vehicle. Charging completed.
		Blink quickly	Charging starts, and the equipment is ready for charging ^[Note] .
		Blink	Charging.
		Steady on	Alarming.
		Steady on	Equipment failure.

Note: After the user starts charging by swiping the card, setting the App, or bypassing authentication, wait for more than 30 s until a "beep" sound gives out. The equipment starts charging. If the user or vehicle actively stops charging or the equipment is malfunctioning during the wait period and four "beep" sounds give out, the charging process stops prematurely.

mySigen App Download and Login

1. Download the app.



2. Provide your email account to the installer for signing up.
3. After signing up your account, the installer will ask you to activate your account.
4. Please check the email sent from the "sigencloud" account in your inbox, set your initial password, and activate your account.
5. Log in to the app.

Single SigenStor Scenario

Binding Sigen RFID Card

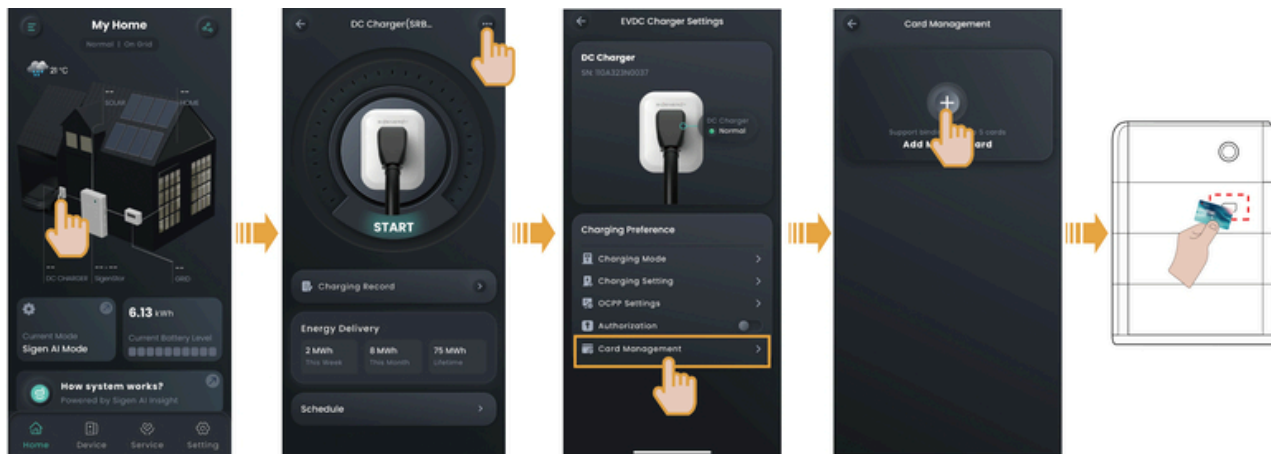

SEA1CM00051

Tips

If an error occurs when you bind the Sigen RFID Card, you can click  and delete the Sigen RFID Card on the "Card Management" page.

Use of Equipment

SigenStor EVDC supports App authenticated charging, Sigen RFID card authenticated, unauthenticated charging and scheduled charging.

Caution

Please carefully read vehicle-related precautions and requirements before charging vehicles.

App authenticated or Sigen RFID card authenticated charging (Recommended)

1. Install the charging connector in place.
2. Start charging on the equipment.

- **Method 1: App authenticated charging**

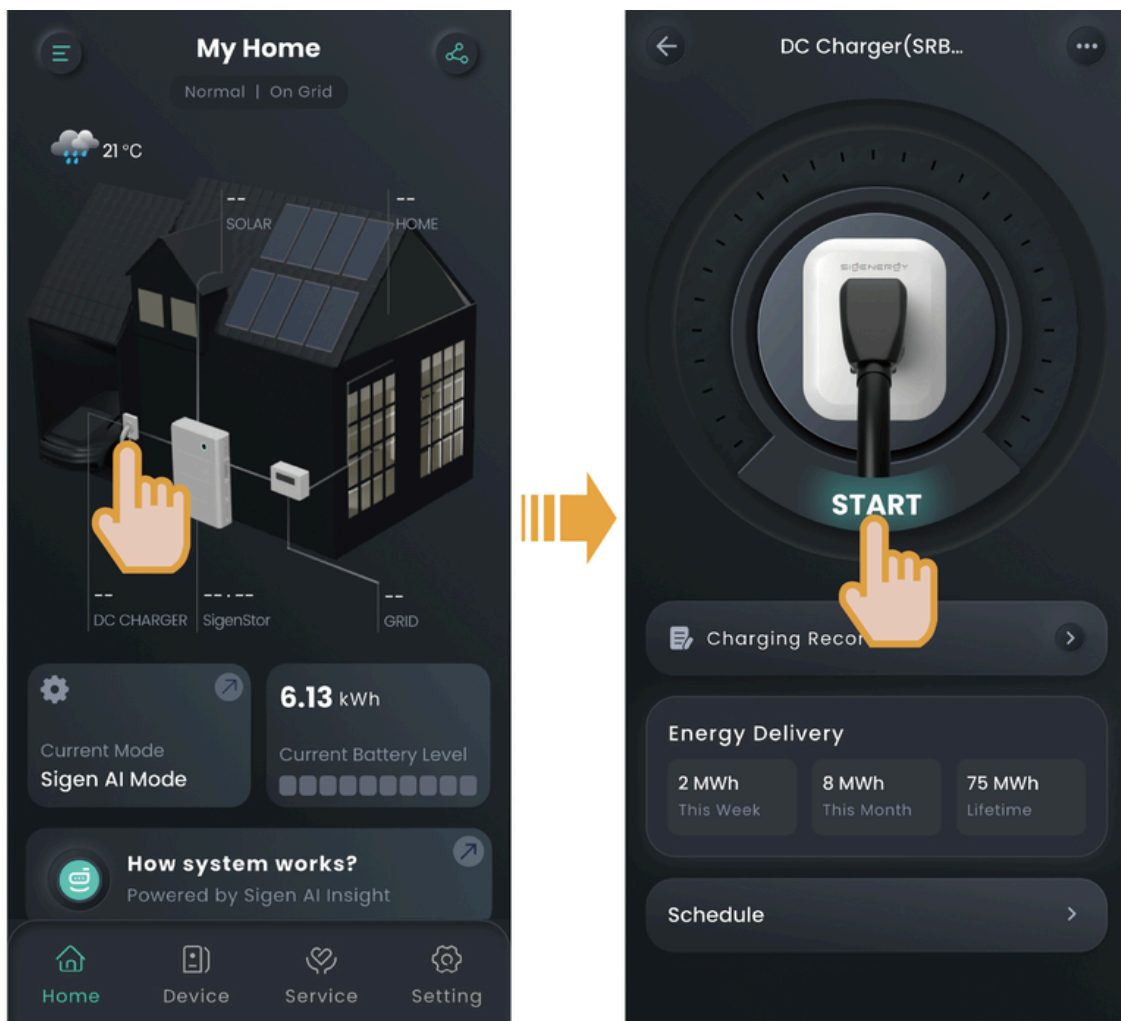

SEA1CM00051

- **Method 2: Sigen RFID card authenticated charging**

Swipe the Sigen RFID Card.

Tips

- **When you use the App or RFID card to start charging the equipment, it will perform a quick self-test, establish communication with the vehicle, and begin charging after about 30s to 40s. Please be patient and do not operate on the equipment, such as operating on the App, repeatedly swiping the card, or re-plugging the charging connector during this period.**
- **If the vehicle cannot be charged, try to re-plug the charging connector, ensure the charging connector is properly connected to the vehicle, and then restart the charging.**

Scheduled Charging

If your vehicle supports scheduled charging, you can add a charging time range.

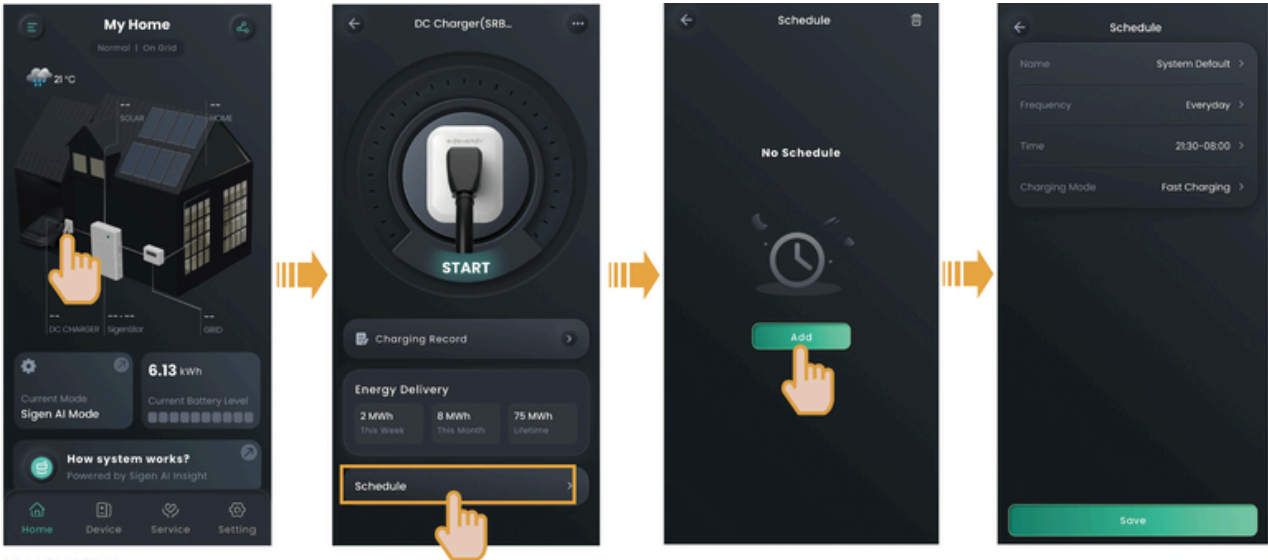

SEA1CM00051

Tips

- **Add the time range available for charging, during which the system will automatically start charging when a vehicle meets charging conditions (the charging connector is installed, and the vehicle is ready to be charged).**
- **When adding a time range, you can set the charging mode for each time range (for an explanation of the charging mode, see [Charging Mode Settings](#)). The system will prioritize the execution of charging mode according to the scheduled command. During the unscheduled time ranges, the charging mode will be executed according to the commands in the setting menu shown in the [Charging Mode Settings](#).**
- **The system will not start charging or will automatically stop charging if the current time is not within the set time range. To start charging, use the App authenticated charging mode or RFID card authenticated charging mode, or change the time range available for charging.**

Unauthenticated Charging Mode

1. Turn "Authentication" off, that is, .



SEA1CM00051

2. Install the charging connector in place.

Tips

- **It should be noted that when the unauthenticated charging mode is enabled, other vehicles can use this equipment for charging.**
- **When you use the App or RFID card to start charging the equipment, it will perform a quick self-test, establish communication with the vehicle, and begin charging after about 30s to 40s. Please be patient and do not operate on the equipment, such as operating on the App, repeatedly swiping the card, or re-plugging the charging connector during this period.**
- **If the vehicle cannot be charged, try to re-plug the charging connector, ensure the charging connector is properly connected to the vehicle, and then restart the charging.**

Stop Charging

Charging completed

The equipment will automatically stop charging when the vehicle is fully charged.

During charging

- **Method 1: During charging**

Read your Sigen RFID Card to stop charging.

- **Method 2: App authenticated**

Stop charging from "Home" →  → "Stop".

Warning

- **If the charging connector is locked because SigenStor EVDC 12 (7.5GBT, 10GBT) or SigenStor EVDC 25 (7.5GBT, 10GBT) stops charging upon fault, you can press the button shown in the figure to unlock the charging connector.**

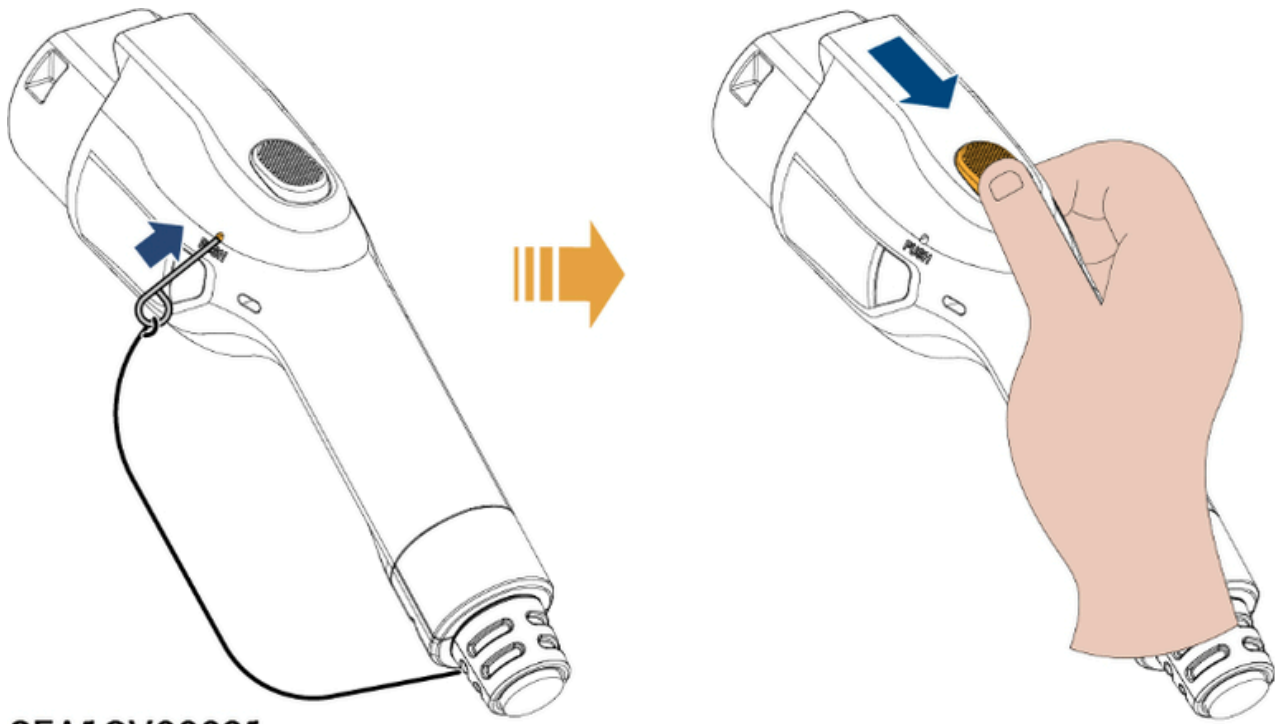

SEA10V00021

- **When the equipment is charging normally or the charging connector has metal damage, do not perform the steps shown in the figure.**

Charging Settings



SEA1CM00051

Charging Mode Settings

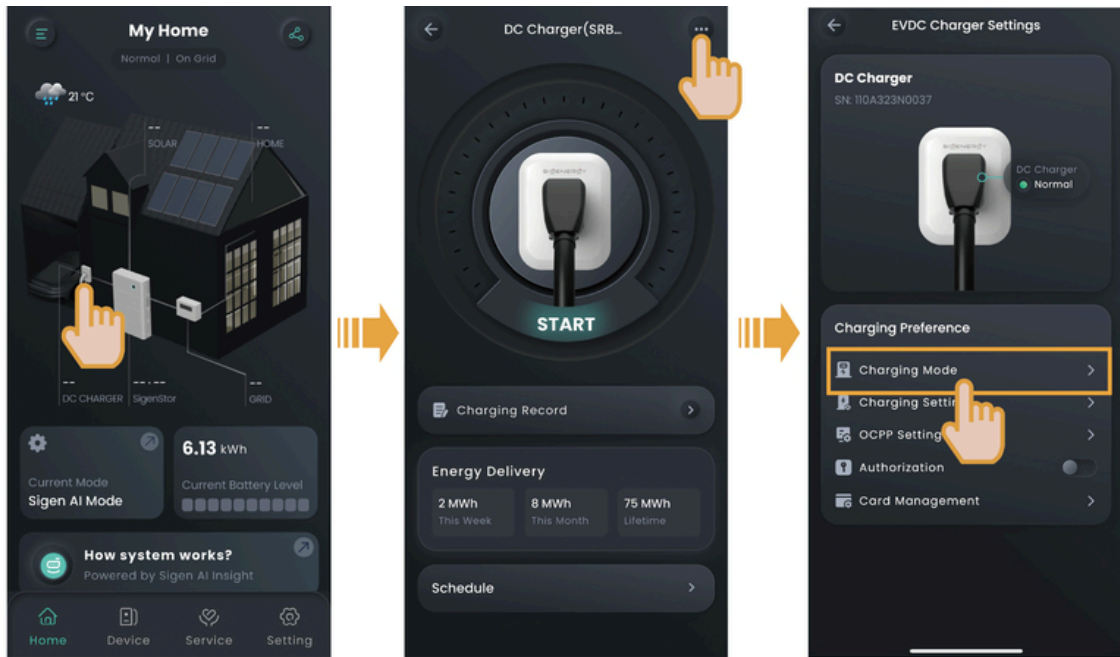

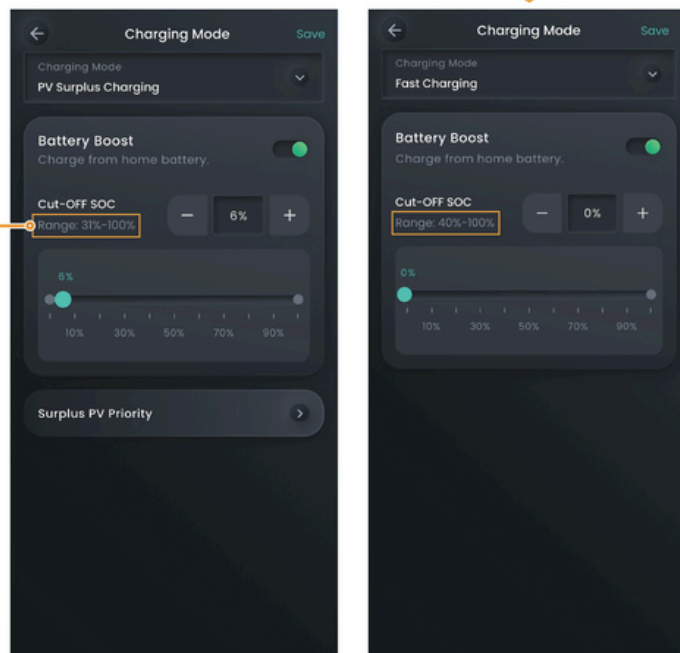

SEA1CM00051

This indicates the recommended settings range. The system dynamically displays optimal values based on the power station's real-time operating conditions.



Fast Charging

- SigenStor EVDC charges the vehicle quickly to the "Vehicle Charging Cut-off SOC" value (see [Charging Settings](#)) at the maximum charging power (the value set for "Charging power allowed for EVDC"), which is the fastest charging speed.

- In this mode, the default priority of the charging power source of SigenStor EVDC is: PV power → discharging power of battery pack → grid input power. You can set whether the battery pack is to be discharged through "Battery Boost". When set to , the battery is allowed to discharge power to SigenStor EVDC to charge the vehicle, and the discharge cutoff SOC can be set. When set to  or the battery is discharged to the set cut-off SOC, SigenStor EVDC is not allowed to draw charging power from the battery pack.

For example: Set the "Working Mode" of SigenStor to "Maximum Self-consumption". SigenStor contains 2 battery packs, each with a rated discharging power of 4 kW, while SigenStor EVDC has a rated charging power of 25 kW. You can set "Battery Boost" to  and the discharge cut-off SOC to 0%. Power distribution under different lighting conditions:

PV power	Battery pack power	Consumed power of load	Compensating power of grid	DC charging power
0 kW	Discharge: 8 kW	6 kW	23 kW	25 kW
23 kW	Discharge: 8 kW	6 kW	0 kW	25 kW
31 kW	0 kW	6 kW	0 kW	25 kW
35 kW	Charge: 4 kW	6 kW	0 kW	25 kW

PV Surplus Charging

Tips

SigenStor EVDC cannot start charging in this mode at nighttime, please use this mode during the daytime.

- When the generated PV power meets the power demand of loads, the surplus PV power is used to charge the device. You can set the priority of using the surplus PV power by dragging the device under the "Surplus PV Priority" menu (the priority is from top to bottom).

- When a device that uses the surplus PV power is set to SigenStor EVDC taking priority over the battery pack, and "Battery Boost" is set to , the battery pack is allowed to discharge, and the surplus PV power and discharging power of battery pack are both supplied to the SigenStor EVDC to charge the vehicle. When the battery pack is discharged to the set cut-off SOC, the battery pack stops discharging.

For example: Set the "Working Mode" of SigenStor to "Maximum Self-consumption". SigenStor contains 2 battery packs, each with a rated discharging power of 4 kW, while SigenStor EVDC has a rated charging power of 25 kW. "Battery Boost" is set to . Power distribution under different lighting conditions:

PV power	Battery pack power	Consumed power of load	Compensating power of grid	DC charging power
0 kW	Discharge: 6 kW	6 kW	0 kW	0 kW
6 kW	0 kW	6 kW	0 kW	0 kW
16 kW	0 kW	6 kW	0 kW	10 kW
31 kW	0 kW	6 kW	0 kW	25 kW
35 kW	Charge: 4 kW	6 kW	0 kW	25 kW

Tips

"Battery Boost" is only used to set whether the battery pack discharges power to the SigenStor EVDC.

OCPP Settings

If you want to manage the SigenStor EVDC through a third-party platform, you can authorize it by configuring the OCPP settings.

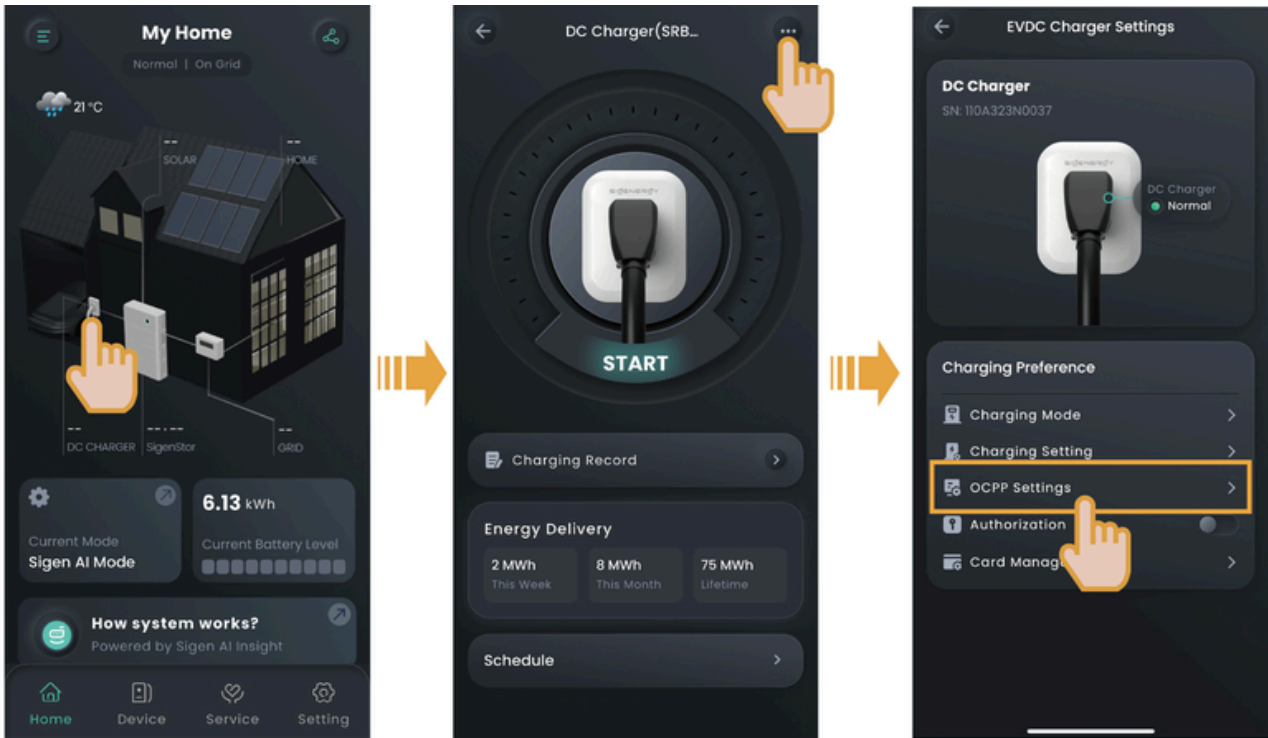

SEA1CM00051

Multiple SigenStor Parallel Scenarios

Binding Sigen RFID Card

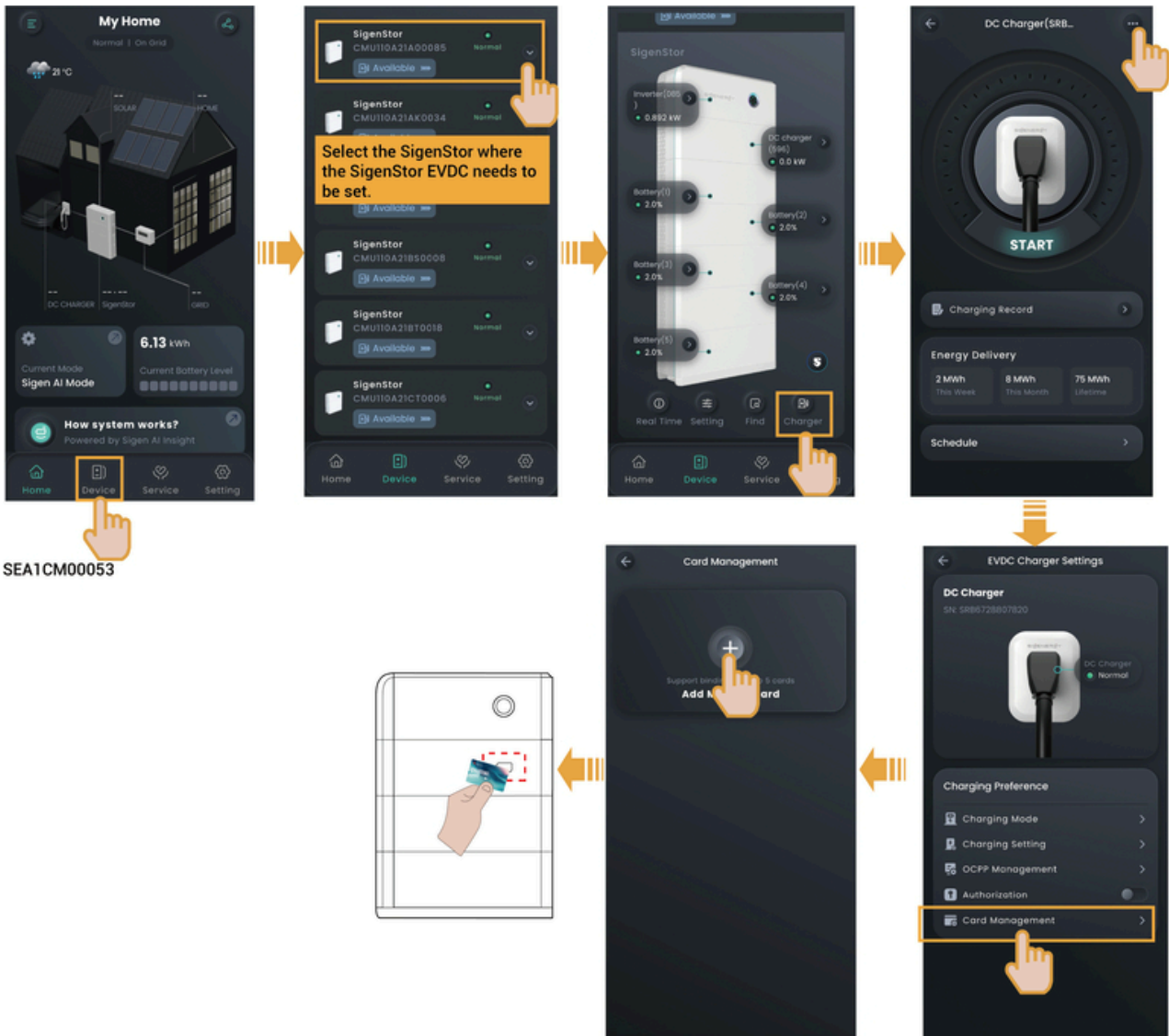

Tips

If an error occurs when you bind the Sigen RFID Card, you can click  and delete the Sigen RFID Card on the "Card Management" page.

Use of Equipment

SigenStor EVDC supports App authenticated charging, Sigen RFID card authenticated, and unauthenticated charging.

Caution

Please carefully read vehicle-related precautions and requirements before charging vehicles.

App authenticated or Sigen RFID card authenticated charging (Recommended)

1. Install the charging connector in place.
2. Start charging on the equipment.

• Method 1: App authenticated charging

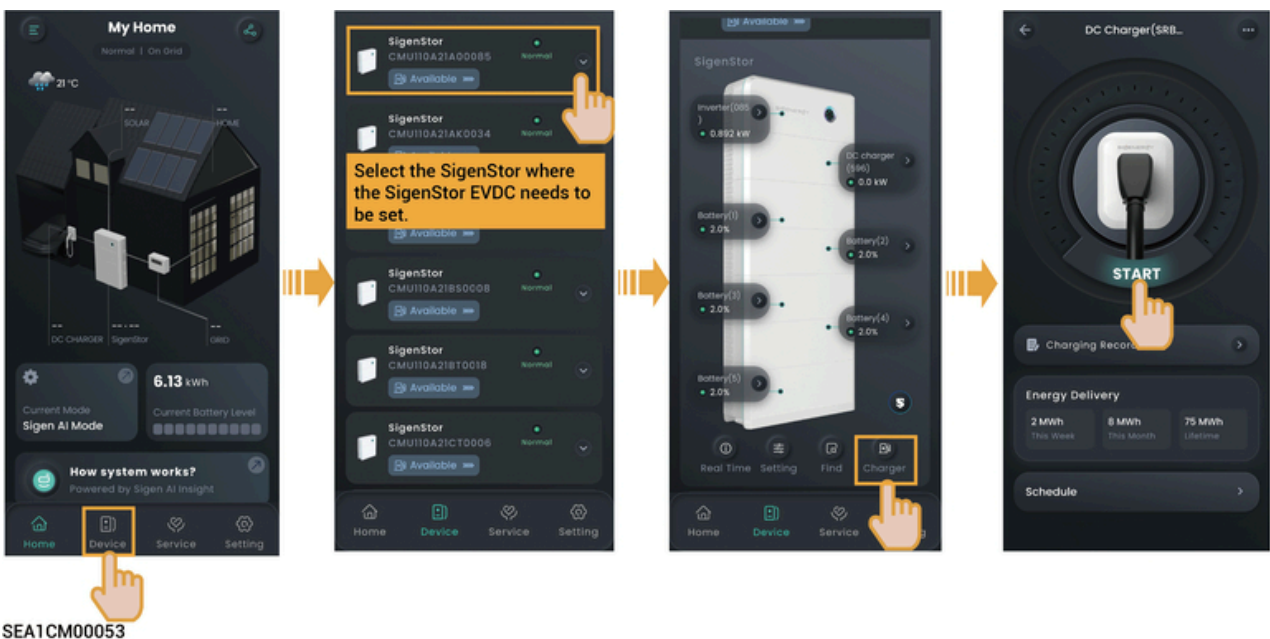

• Method 2: Sigen RFID card authenticated charging

Swipe the Sigen RFID Card.

Tips

- When you use the App or RFID card to start charging the equipment, it will perform a quick self-test, establish communication with the vehicle, and begin charging after about 30s to 40s. Please be patient and do not operate on the equipment, such as operating on the App, repeatedly swiping the card, or re-plugging the charging connector during this period.

- **If the vehicle cannot be charged, try to re-plug the charging connector, ensure the charging connector is properly connected to the vehicle, and then restart the charging.**

Scheduled Charging

If your vehicle supports scheduled charging, you can add a charging time range.

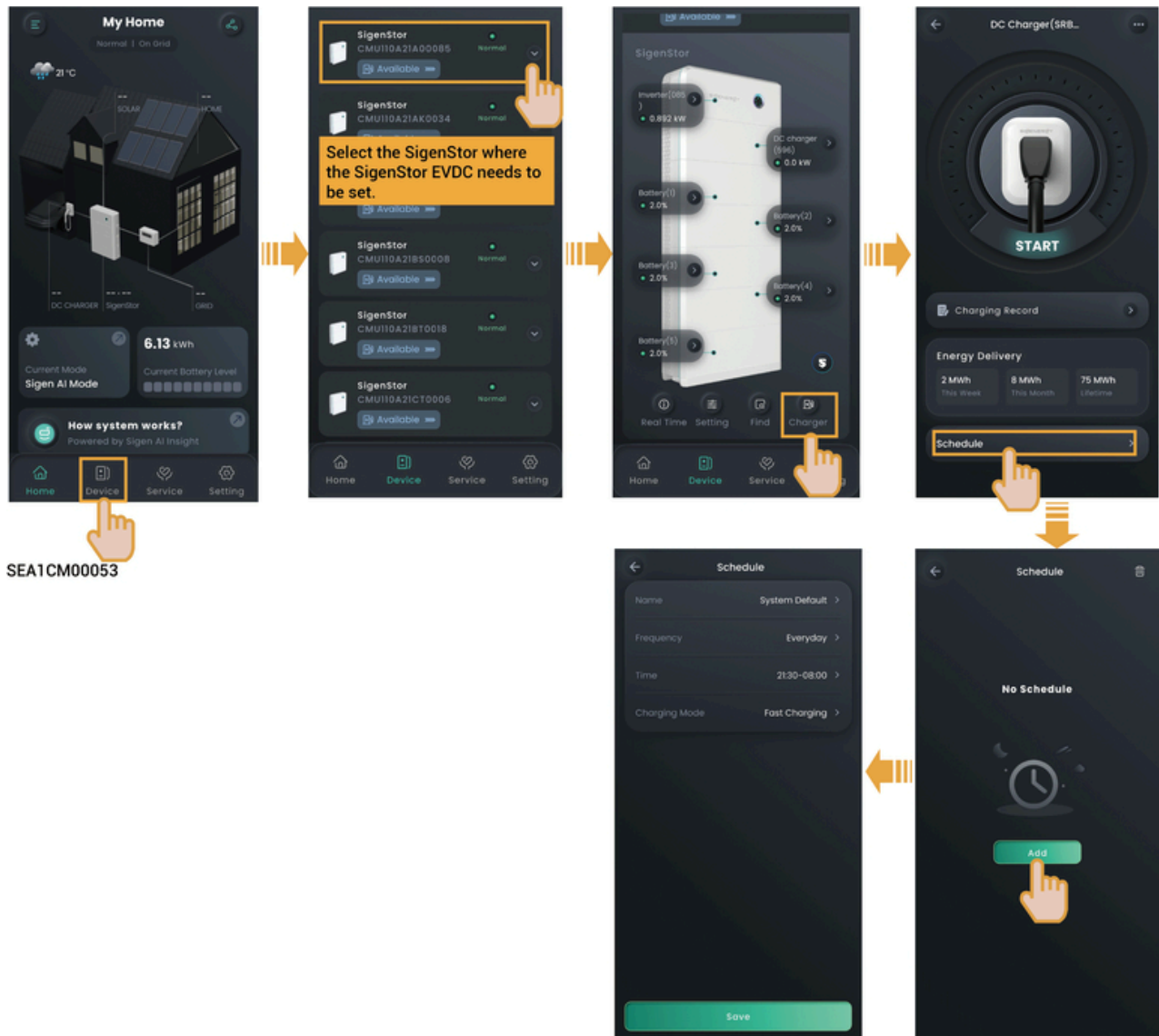

Tips

- **Add the time range available for charging, during which the system will automatically start charging when a vehicle meets charging conditions (the charging connector is installed, and the vehicle is ready to be charged).**
- **When adding a time range, you can set the charging mode for each time range (for an explanation of the charging mode, see [Charging Mode](#)**

Settings). The system will prioritize the execution of charging mode according to the scheduled command. During the unscheduled time ranges, the charging mode will be executed according to the commands in the setting menu shown in the **Charging Mode Settings**.

- **The system will not start charging or will automatically stop charging if the current time is not within the set time range. To start charging, use the App authenticated charging mode or RFID card authenticated charging mode, or change the time range available for charging.**

Unauthenticated Charging Mode

1. Turn "Authentication" off, that is, .

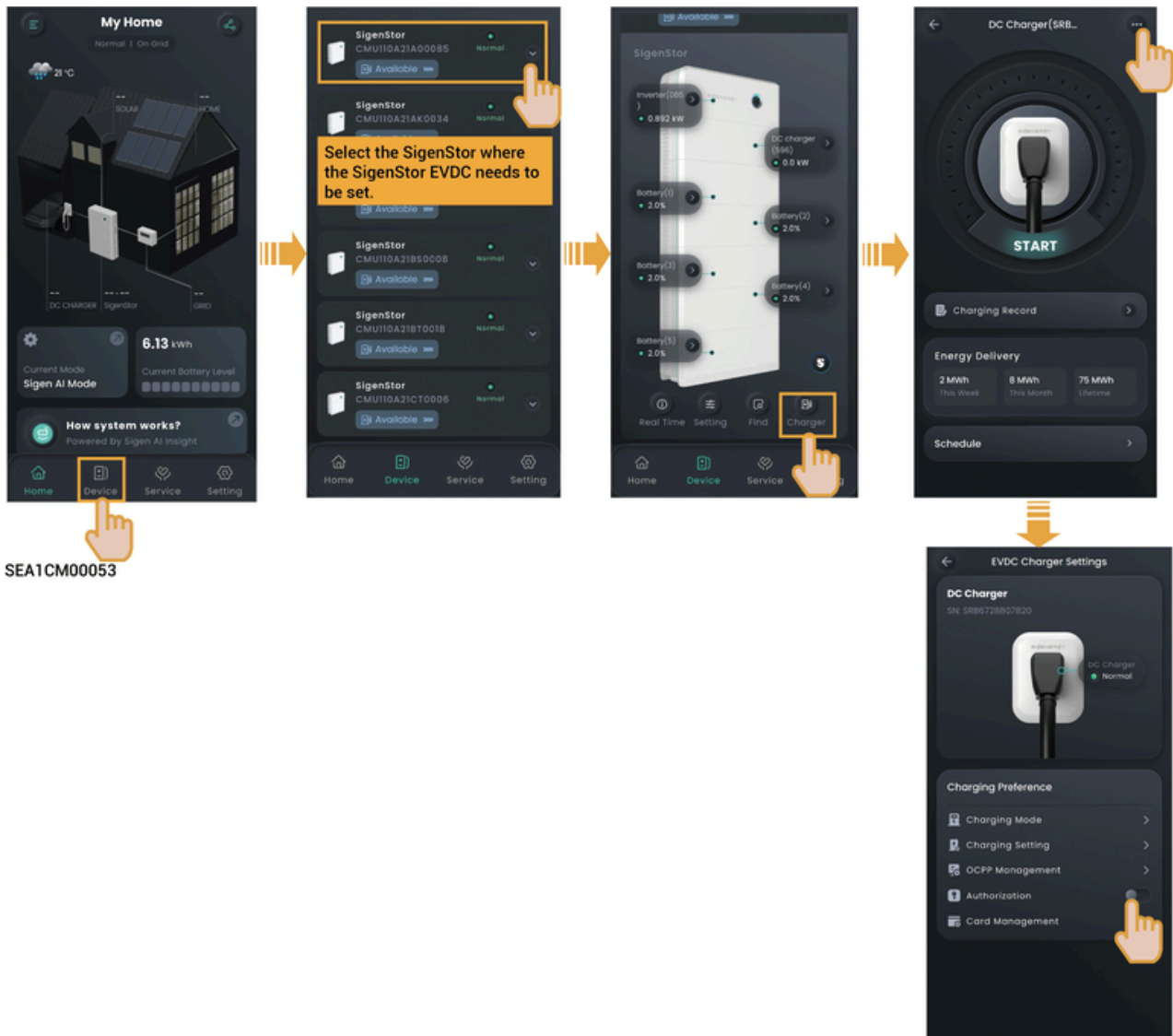

2. Install the charging connector in place.

Tips

- It should be noted that when the unauthenticated charging mode is enabled, other vehicles can use this equipment for charging.
- When you use the App or RFID card to start charging the equipment, it will perform a quick self-test, establish communication with the vehicle, and begin charging after about 30s to 40s. Please be patient and do not

operate on the equipment, such as operating on the App, repeatedly swiping the card, or re-plugging the charging connector during this period.

- **If the vehicle cannot be charged, try to re-plug the charging connector, ensure the charging connector is properly connected to the vehicle, and then restart the charging.**

Stop Charging

Charging completed

The equipment will automatically stop charging when the vehicle is fully charged.

During charging

- **During charging**

Read your Sigen RFID Card to stop charging.

- **Method 2: App authenticated**

Stop charging from "Home" → "Charger" → "Stop".



Warning

- **If the charging connector is locked because SigenStor EVDC 12 (7.5GBT, 10GBT) or SigenStor EVDC 25 (7.5GBT, 10GBT) stops charging upon fault, you can press the button shown in the figure to unlock the charging connector.**

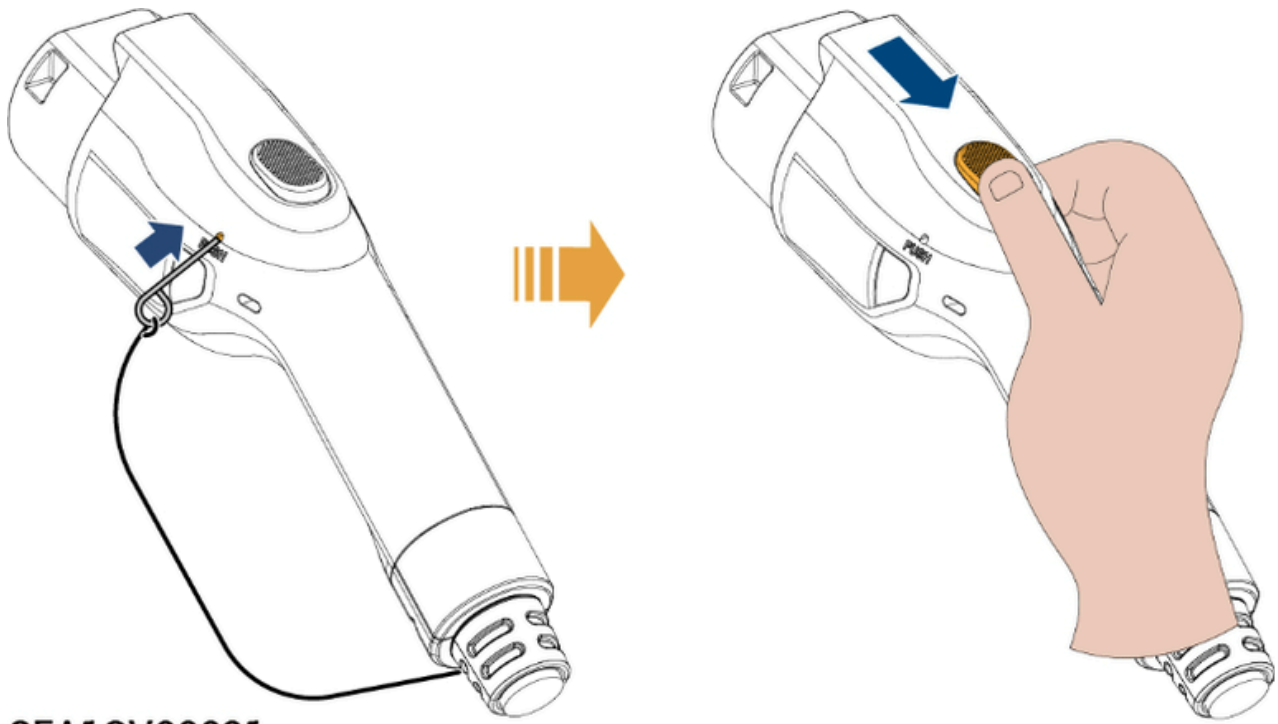

SEA10V00021

- **When the equipment is charging normally or the charging connector has metal damage, do not perform the steps shown in the figure.**

Charging Settings

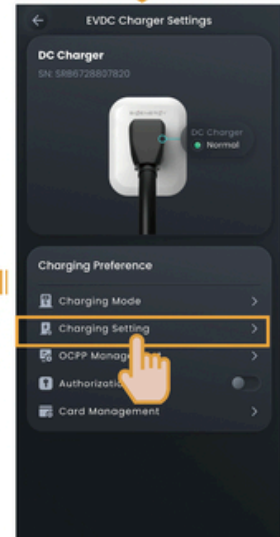
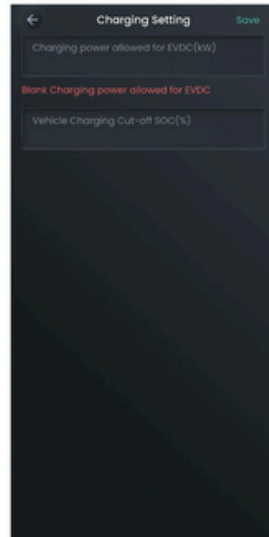
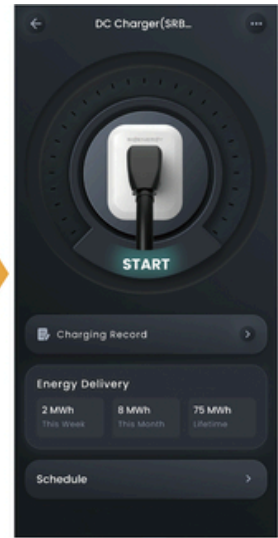
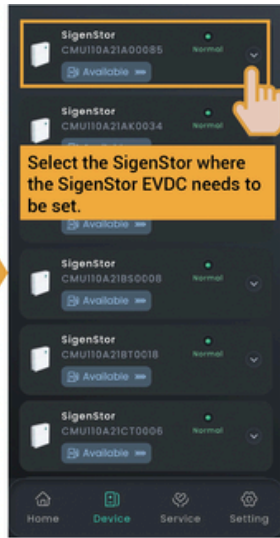

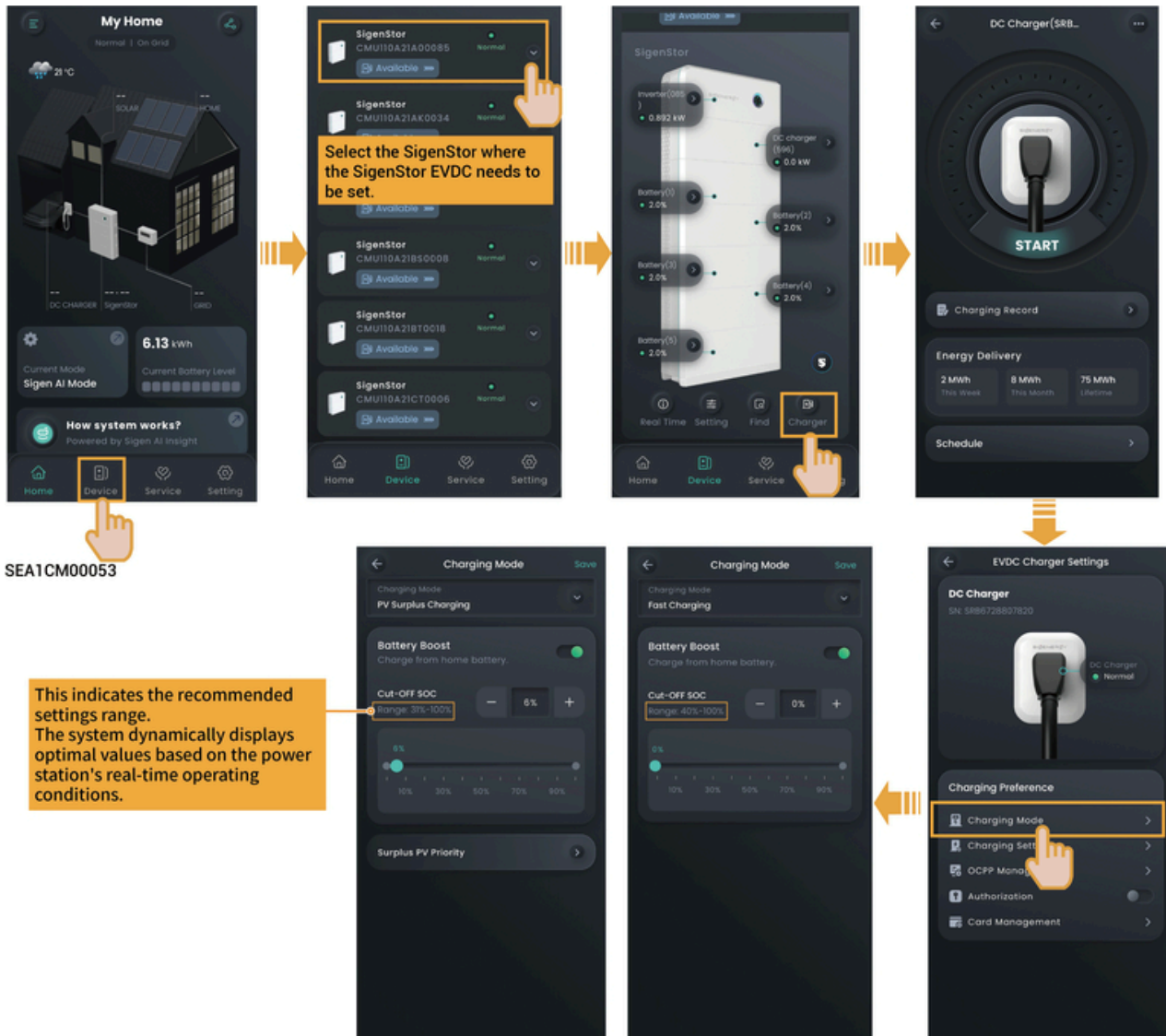

Charging Mode Settings



Fast Charging

- SigenStor EVDC charges the vehicle quickly to the "Vehicle Charging Cut-off SOC" value (see [Charging Settings](#)) at the maximum charging power (the value set for "Charging Power allowed for EVDC"), which is the fastest charging speed.
- In this mode, the default priority of the charging power source of SigenStor EVDC is: PV power → discharging power of battery pack → grid input power. You can set whether the battery pack is to be discharged through "Battery Boost". When set to , the battery is allowed to discharge power to SigenStor EVDC to charge the vehicle, and the discharge cutoff SOC can be

set. When set to  or the battery is discharged to the set cut-off SOC, SigenStor EVDC is not allowed to draw charging power from the battery pack.

For example: Set the "Working Mode" of SigenStor to "Maximum Self-consumption". SigenStor contains 2 battery packs, each with a rated discharging power of 4 kW, while SigenStor EVDC has a rated charging power of 25 kW. You can set "Battery Boost" to  and the discharge cut-off SOC to 0%. Power distribution under different lighting conditions:

PV power	Battery pack power	Consumed power of load	Compensating power of grid	DC charging power
0 kW	Discharge: 8 kW	6 kW	23 kW	25 kW
23 kW	Discharge: 8 kW	6 kW	0 kW	25 kW
31 kW	0 kW	6 kW	0 kW	25 kW
35 kW	Charge: 4 kW	6 kW	0 kW	25 kW

PV Surplus Charging

Tips

SigenStor EVDC cannot start charging in this mode at nighttime, please use this mode during the daytime.

- When the generated PV power meets the power demand of loads, the surplus PV power is used to charge the device. You can set the priority of using the surplus PV power by dragging the device under the "Surplus PV Priority" menu (the priority is from top to bottom).
- When a device that uses the surplus PV power is set to SigenStor EVDC taking priority over the battery pack, and "Battery Boost" is set to , the battery pack is allowed to discharge, and the surplus PV power and discharging power of battery pack are both supplied to the SigenStor EVDC

to charge the vehicle. When the battery pack is discharged to the set cut-off SOC, the battery pack stops discharging.

For example: Set the "Working Mode" of SigenStor to "Maximum Self-consumption". SigenStor contains 2 battery packs, each with a rated discharging power of 4 kW, while SigenStor EVDC has a rated charging power of 25 kW. "Battery Boost" is set to . Power distribution under different lighting conditions:

PV power	Battery pack power	Consumed power of load	Compensating power of grid	DC charging power
0 kW	Discharge: 6 kW	6 kW	0 kW	0 kW
6 kW	0 kW	6 kW	0 kW	0 kW
16 kW	0 kW	6 kW	0 kW	10 kW
31 kW	0 kW	6 kW	0 kW	25 kW
35 kW	Charge: 4 kW	6 kW	0 kW	25 kW

Tips

"Battery Boost" is only used to set whether the battery pack discharges power to the SigenStor EVDC.

OCPP Settings

If you want to manage the SigenStor EVDC through a third-party platform, you can authorize it by configuring the OCPP settings.



SEA1CM00053



Other Settings of mySigen App

For more information about the app settings, refer to ***mySigen App User Manual***.

Routine Maintenance

To ensure the long-term operation of the equipment, you are advised to perform routine maintenance according to this section.

Inspection content	Inspection method	Power off or not	Maintenance cycle
System cleaning	Regularly check the equipment for blocking out or dust contamination. If so, clean it up. Do not use tools that may cause electric shock or insulation damage, such as wire brushes during the cleaning process.	Yes	Once every three months.
System operating state	<ul style="list-style-type: none"> • Check whether the equipment is damaged or deformed. • Listen for any abnormal noises during the operation of the equipment. • When the equipment is operating, check whether the equipment parameters are correctly set. 	No	Once every six months.

Technical Parameter

For details about equipment parameters, see the Data sheets of the product.