

# User Manual

## DC Charger

IDC180E



---

# All Rights Reserved

## **All Rights Reserved**

No part of this document can be reproduced in any form or by any means without the prior written permission of Sungrow Power Supply Co., Ltd (hereinafter "SUNGROW").

## **Trademarks**

**SUNGROW** and other SUNGROW trademarks used in this manual are owned by SUNGROW.

All other trademarks or registered trademarks mentioned in this manual are owned by their respective owners.

## **Software Licenses**

- It is prohibited to use data contained in firmware or software developed by SUNGROW, in part or in full, for commercial purposes by any means.
- It is prohibited to perform reverse engineering, cracking, or any other operations that compromise the original program design of the software developed by SUNGROW.

# About This Manual

## Declaration

To ensure the safe use of the product, please read through the below information carefully:

1. The warranty period agreed for this product is subject to the contract.
2. This manual is intended for personnel who are responsible for product installation and other work on the product. Users must have certain electrical and mechanical expertise, and be familiar with the electrical and mechanical schematics and the characteristics of electronic components. SUNGROW shall not be held liable for any personal injury or financial loss arising from the installation operation carried out by non-qualified personnel or not in compliance with the safety instructions specified in this manual.
3. The content of this manual, including the pictures, marks, and symbols used herein, is all owned by SUNGROW. No part of this manual may be reproduced by any non-internal staff without the prior written authorization of SUNGROW.
4. The manual may be updated and revised from time to time, however, there still might be slight deviations from the real product or errors. In such cases, the actual product you have purchased should take precedence. You can find the latest version of the user manual on the company website, or reach your sales for it.
5. To ensure the safety of the installation personnel, the product, and the system, follow strictly the safety instructions specified in this manual when installing the product. SUNGROW shall not be held liable for any personal injury or financial loss arising from failure to follow the instructions specified in this manual.
6. If maintenance on or alteration to this product is needed, please contact SUNGROW customer service in advance. The copyright of this user manual belongs to SUNGROW, and any rights not expressly granted are reserved. The content of the manual is subject to change without notice and the actual up-to-date product shall prevail.

## Valid for

Product Model	Product Aliases
IDC180E	Charger, "the device/product"

## Target Group

This manual is intended for qualified technical persons who are responsible for the installation, operation, and maintenance of the product, as well as people who use the product for charging. Installation must only be performed by qualified technical persons, and qualified technical persons must be:

- Have certain electrical wiring, electronic, and mechanical expertise, and be familiar with electrical and mechanical schematics;

- Have received professional training in the installation and commissioning of electrical equipment;
- Be able to respond quickly and effectively to dangers or emergencies that may occur during the process of installation and commissioning;
- Be familiar with applicable local standards and specifications of the country/region where the project is located;
- Read through this manual carefully and have a good understanding of the relevant safety instructions.

### How to Use This Manual

Read through this manual carefully before using the product, and keep it properly in an easy-to-reach place. The manual may be updated and revised from time to time, however, there still might be slight deviations from the real product or errors. In such cases, the actual product you have purchased should take precedence. You can also download the latest version of the user manual at [support.sungrowpower.com](http://support.sungrowpower.com).

### Symbols in the Manual

To ensure the safe and efficient use of the product, the manual provides relevant safety information, which are highlighted using relevant symbols. Symbols that may appear in this manual are listed below, but not all. Please read carefully for better use of this manual.

#### **DANGER**

Indicates an imminently hazardous situation which, if not avoided, will result in death or serious injury.

#### **WARNING**

Indicates a moderately hazardous situation which, if not avoided, will result in death or serious injury.

#### **CAUTION**

Indicates a slightly hazardous situation which, if not avoided, may result in minor or moderate injury.

#### **NOTICE**

Indicates a potential hazard which, if not avoided, will result in device malfunction or property damage.



Indicates supplementary information, emphasis on specific points, or tips related to the use of the product that might help to solve your problems or save your time.

# Contents

---

All Rights Reserved.....	I
About This Manual.....	II
<b>1 Safety Instructions.....</b>	<b>1</b>
1.1 Safety Signs on Product.....	1
1.2 Packaging, Transport, and Storage.....	2
1.3 Installation Safety.....	3
1.4 Electrical Safety.....	4
1.5 Operation Safety.....	5
1.6 Maintenance Safety.....	6
1.7 Disposal Safety.....	7
<b>2 Product Description.....</b>	<b>8</b>
2.1 About the EV Charging System.....	8
2.2 Product Overview.....	9
2.3 Application Scenarios.....	10
2.4 Operating Principle.....	11
2.5 Marks on the Product.....	12
2.6 Product Exterior.....	14
2.7 Internal Structure.....	15
2.8 Indicators.....	16
2.9 Charging Cable Specifications.....	17
<b>3 Installation.....</b>	<b>19</b>
3.1 Installation Requirements.....	19
3.2 Installation Tools.....	21
3.3 Packing List.....	22
3.4 Foundation Building.....	24
3.5 Charger Moving and Handling.....	26
3.5.1 Handle with Crane.....	26
3.5.2 Handle with Forklift.....	28
3.6 Electrical Connection.....	28
3.6.1 Preparation Before Wiring.....	28
3.6.2 Crimp OT/DT terminal.....	30
3.6.3 Protective Grounding Cable Connection.....	32
3.6.4 AC Cable Connection.....	33
3.6.5 Communication Interfaces.....	36

3.6.6 Communication Cable Connection.....	38
<b>4 Commissioning.....</b>	<b>40</b>
4.1 Inspection Before Commissioning.....	40
4.2 Commissioning Procedure.....	41
<b>5 LCD Touch Screen.....</b>	<b>44</b>
5.1 Start Charging.....	44
5.1.1 Select an Authentication Method.....	45
5.1.2 Select a Charging Connector.....	49
5.1.3 Plug Connector for Charging.....	50
5.1.4 End a Charging Process.....	52
5.2 Other Functions.....	53
5.2.1 Switch Between Connectors.....	53
5.2.2 Change System Language.....	54
5.2.3 Emergency Stop.....	54
5.2.4 Device Fault Diagnosis.....	54
5.2.5 Network Connection Diagnosis.....	55
<b>6 iEnergyCharge App.....</b>	<b>56</b>
6.1 Download and Installation.....	56
6.2 Sign-up and Log in.....	56
6.3 Add a Charger.....	57
<b>7 Routine Inspection.....</b>	<b>58</b>
7.1 Inspection Instructions.....	58
7.2 Routine Inspection.....	58
<b>8 Troubleshooting and Maintenance.....</b>	<b>61</b>
8.1 Troubleshooting.....	61
8.2 Power Off Charger.....	65
8.3 Replace Power Unit.....	66
8.4 Routine Dust Removal.....	67
<b>9 Appendix.....</b>	<b>69</b>
9.1 Technical Data.....	69
9.2 Quality Assurance.....	72
9.3 Contact Information.....	72

# 1 Safety Instructions

Follow strictly the relevant safety instructions during the process of product installation, commissioning, operation, and maintenance. Improper use or misoperation may result in:

- Injury to or death of the operator or other people.
- Damage to the product, or to the property that belongs to the operator or a third party.

Strictly follow the safety instructions stated in the manual to avoid the hazards mentioned above.



- Safety instructions in this manual should only serve as a supplement and not all-encompassing regarding all the norms that need to be followed. All work should be carried out considering the actual situation on the site.
- SUNGROW shall not be held liable for any damage caused by violation of general safe operation requirements, safety standards, and the safety instructions specified in this manual.
- Product installation, operation, and maintenance should be conducted in compliance with applicable local laws, regulations, and specifications. Safety instructions in this manual should only be a supplement to the local laws, regulations, and specifications.

## 1.1 Safety Signs on Product

To ensure users' personal and property safety, warning signs are provided on the product, which should be observed at all times.

**Table 1-1 Safety Signs on the Product**

Symbols	Description
	Burn hazard due to the hot surface that may exceed 60°C.
	Disconnect the device from all the external power sources before maintenance.
	Danger to life due to high voltages! Only qualified personnel can open and maintain the device.

## 1.2 Packaging, Transport, and Storage

### Packaging

- The product is packed in a cardboard box with orientation markings that provide loading and unloading instructions.
- Use brushed film to wrap the product tightly, put foam guards around it for protection, and then put it in the cardboard box.

### Transport

- All work related to transport must be carried out in compliance with the applicable local laws and regulations of the country/region.
- Do not turn the product upside down during transport.
- Measures should be taken to fasten the goods during transport, so as to avoid damages to product packaging due to strong shaking or bumping.
- Carry out an inspection upon receiving the delivery. In case of any damage to the goods during transport, contact your transport service provider and SUNGROW for negotiation.

### Storage

- The packaged product should be stored indoors in places with a relative humidity of 5% to 95% and ambient temperature of -40°C to 70°C.
- The place where the product is stored should be kept dry, clean, and well-ventilated, protected from hazardous gases.
- Do not store the product in a place where corrosives are kept.

### Unpacking and Inspection

#### NOTICE

Non-qualified personnel are forbidden from disassembling the product or moving its components.

- Non-qualified personnel are forbidden from disassembling the product or moving its components.
- Check if the product you have received matches the order you placed.
- Check if the items packed in the box matches the packing list.
- Inspect the product for external damages or damages to its structural parts.
- Check if the safety signs, warning labels, and the nameplate on the product are all legible.
- In case of any problem with the above-mentioned inspection items, do not proceed with installation and contact SUNGROW in time.

## 1.3 Installation Safety

Improper installation operation may result in personal injuries, while poor operating environments may affect the charging efficiency. Therefore, installation personnel must read through the instructions specified in this section carefully before installing the product.

### Installation Notice

- All work related to installation must be conducted in compliance with the applicable local laws and regulations of the country/region.
- Proceed with the subsequent work only if the qualified personnel designated by SUNGROW confirm that the environment where the product is to be installed meets the requirements after an assessment.
- Perform installation only if the product is intact without any signs of damage.
- Installation must be performed by qualified personnel who wear proper personal protective equipment.
- Ensure all electrical connections of the product have been disconnected before installation.
- Before installation, inspect the products and tools to be used and ensure they have all undergone regular maintenance.
- Where hole drilling is required during installation, avoid the internal water pipes and electrical wires when drilling.
- Install the product in a well-ventilated place.
- Do not install the product in an environment with flammables, explosives, or smoke.
- Stop the installation in the event of severe weather such heavy rain, heavy fog, or strong wind.

### Handling Notice

- Installation personnel should wear protective equipment such as anti-impact shoes and safety gloves when handling the product to ensure their own safety.
- When handling the product, get prepared for carrying its weight and keep the balance to prevent it from tilting or falling.
- Do not let go of the product during handling, unless it has been fastened securely.
- The sealed wood crate or tray, upon its arrival on the site, must be loaded/unloaded and handled with a crane or forklift that has sufficient load capacity and is operated by qualified personnel.

### Notice for Handling with a Crane

- Use only specialized cranes that are operated by qualified personnel.
- The load capacity of the crane should meet the requirements of the product's specification.
- The slings must all have a tensile strength and length that meet the requirements.
- The lifting rings on the top of the product are firmly attached.
- No one is allowed to stay under the product when it is lifted up.

- When rotating the crane for unloading, keep it rotating at a low speed. Keep the product steady and as close to the ground as possible.
- Do not shake the slings during handling.
- Do not keep the product lifted up for a long period of time.
- Do not drag the product along any surface.

#### **Notice for Handling with a Forklift**

- Use only specialized forklifts that are operated by qualified personnel.
- The carrying capacity of the forklift should meet the requirements of the product's specification.
- Make sure there are no obstacles, slopes, or other unevenness along the moving path of the product.

## **1.4 Electrical Safety**

Improper wiring may result in personal injuries. Hence, installation personnel must read through the wiring instructions carefully before proceeding with this work.

#### **Wiring Notice**

#### **DANGER**

- Electrical connection must be performed by qualified personnel who wear personal protective equipment.
  - Be sure to use specialized insulated tools when performing electrical connection.
- 
- All work related to wiring must be conducted in compliance with the applicable local laws and regulations of the country/region.
  - Wiring must be done in compliance with the applicable local grid regulations and relevant safety instructions specified for the product.
  - The specification of cables used should meet the relevant requirements. The cables should be properly insulated and firmly connected.
  - Observe the warning signs on the product, and perform operations by strictly following the corresponding safety instructions.
  - Before electrical connection, make sure the product is not damaged. Otherwise, it may cause danger.
  - Before electrical connection, make sure the product's switches and all switches connected to it are turned "OFF"; otherwise, it may lead to electric shocks.
  - Before electrical connection, be sure to test with a measuring instrument and confirm the cables are voltage-free.
  - Improper wiring may cause damage to the product and such damages will not be covered by warranty.

## 1.5 Operation Safety

There is high voltage inside the product when it is running, and improper operation may cause personal injuries or property damages. Please perform operations by strictly following the safety instructions specified in this manual and other relevant documents when charging EVs.

### Operation Notice

#### DANGER

- Do not touch any live part of the product when it is running; otherwise, it may lead to electrical shocks.
  - Do not touch any wiring terminal on the product when it is running; otherwise, it may lead to electrical shocks.
  - Do not remove any part or component from the product when it is running; otherwise, it may lead to electrical shocks.
- 
- Operations must all be performed in compliance with the applicable local laws and regulations of the country/region.
  - Do not use an extension cable when connecting the EV to the dispenser.
  - Do not bend, squeeze, or crush the charging connector, which may result in mechanical damage.
  - Only EVs can be connected to the charging dispenser. Do not connect any other devices for charging (e.g., electric tools).
  - Make sure the charging connector does not come into contact with heat, dirt, or water.
  - Please handle the charging connector gently. Plug or unplug the connector neatly at one go, and do not shake it.
  - Start charging only when the car sits perfectly still. Do not start the car in the middle of a charging process.
  - If the product is not covered by a rainproof shield, please charge with caution in the event of a thunderstorm.
  - Do not use the dispenser when its charging connector or cable is defective, frayed, cracked, or in case of exposed wires. Contact SUNGROW if you have found any of the above issues.
  - Do not plug or unplug any connector of the dispenser during the charging process.
  - During the charging process, do not let children go near or use the dispenser, so as to prevent them from getting hurt.
  - During the charging process, do not touch any hot part of the product (e.g., air outlet for heat dissipation); otherwise, it may cause burns.
  - After charging, insert the charging connector back into the holder on the dispenser, so as to avoid the ingress of water or sand into the connector. Also, put away the cable in time and keep it in a place out of the vehicle's reach so that it will not get run over.
  - In case of anything abnormal during use, press the emergency stop button immediately and cut off the power supply.

## 1.6 Maintenance Safety

There is high voltage inside the product when it is running, and improper maintenance operation may cause personal injuries or property damages. Therefore, it is necessary to power off the product before maintenance and perform operations by strictly following the safety instructions specified in this manual and other relevant documents.

### Maintenance Notice

#### DANGER

- Only when no current or voltage is present, qualified personnel, who wear protective equipment, can perform maintenance.
  - Do not touch the pins inside the charging connector when it is powered on.
- 
- All work related to maintenance must be done in compliance with the applicable local laws and regulations of the country/region.
  - Perform maintenance only when you have a good understanding of this manual and appropriate tools and testing instruments.
  - It is required to inspect the charging connector for damages on a regular basis and check if its enclosure is in a good state and supporting facilities are all in readiness.
  - Keep the charging connector clean and dry. Wipe it off using a clean dry cloth in case of any dirt.
  - Wait at least 10 minutes after the product stops running. Proceed with maintenance after confirming the voltage has lowered to a safe level.
  - Even if the product has stopped running, it may still be hot and cause burns. Perform operations on the product wearing protective gloves after it cools down.
  - Before maintenance, be sure to check the warning labels inside the product and follow the corresponding instructions.
  - Before maintenance, make sure the product, the external devices connected to it, and the electrical connections are in a safe state.
  - During the maintenance process, prevent irrelevant personnel from entering the site, whenever possible. Set up temporary warning signs or fence off an area to keep irrelevant personnel away and avoid accidents.
  - Maintenance should be performed by following the electrostatic protection rules.
  - Stop maintenance in the event of extreme weather.
  - Only after faults that may affect its safety performance are all removed, the product can be powered on again.
  - For the product that has a long downtime, a thorough and detailed inspection must be carried out before powering it on again. Only after it is inspected and tested by qualified personnel, it can be powered and put into operation again.
  - To minimize the risk of electric shocks, do not perform maintenance operations that are not specified in this manual. If needed, please contact SUNGROW for maintenance and repair services. Otherwise, damages caused therefrom will not be covered by the warranty.

## 1.7 Disposal Safety

Please dispose of the decommissioned product strictly in accordance with applicable local regulations and standards to avoid property damages or personal injuries.

### **Disposal Notice**

- All work related to product disposal must be done in compliance with the applicable local laws and regulations of the country/region.
- Ensure the safety signs, warning labels, and the nameplate on the product are all legible before disposal.

## 2 Product Description



The image shown here is for reference only. The actual product received may differ. Changes may be made without prior notice.

### 2.1 About the EV Charging System

As electric vehicles (EVs) are gaining greater popularity, the EV charging demand is now witnessing constant growth. The EV charging system is constituted by the EV, charger, AC grid, and charging management system, as shown in the figure below. It is used to satisfy the demand for EV charging.

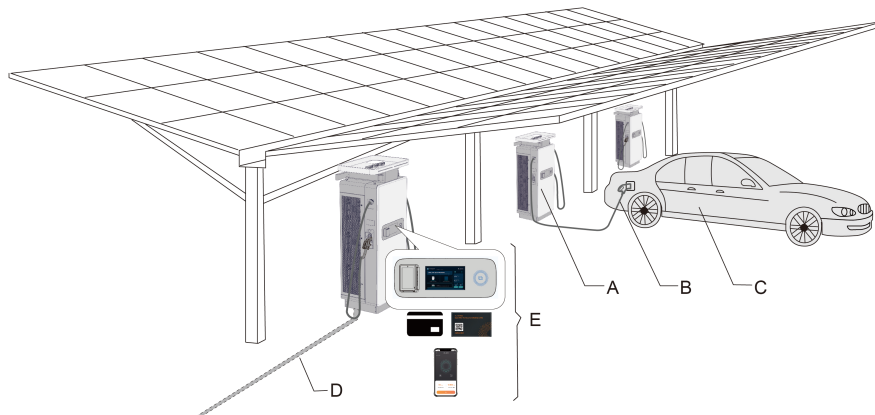

Figure 2-1 EV Charging System

Table 2-1 EV Charging System Composition

No.	Name	Description
A	Charger	Device used to charge the EV.
B	Charging connector	Used to charge the EV with power from the charger.
C	Electric vehicle (EV)	EV to be charged. It has a power battery inside. The EV charging system is actually used to charge the power battery inside the vehicle.

No.	Name	Description
D	AC grid input	Power source for the EV charging system, which is used to supply the charger.
E	Charging management system	Charger operation and management system for users. With this system, users can look for their chargers, start/stop charging, and view charging data, etc.

### Charger Type

A charger is a device used in the EV charging system to charge the vehicles. There are two types of charger, based on its charging methods:

- AC charger: It supplies the EV with AC power. The AC charger itself is not capable of charging the EV and should work in conjunction with the OBC (onboard charger) inside the EV to charge the vehicle. The charging takes a longer time when using an AC charger.
- DC charger: It supplies the EV with DC power. A DC charger does not need to be used with an OBC as it can charge the EV directly. The charging takes a shorter time when using a DC charger.

## 2.2 Product Overview

IDC180E is an integrated DC charger, with a rated power of 180kW, manufactured by SUNGROW. It is mainly used in public charging stations for quick EV charging.

The IDC180E charger is equipped with an LCD display. Except for charging their cars, users can also view the charging data, set the parameters, and perform fault diagnosis, etc. For details, see [5 LCD Touch Screen](#).

### Product Model

The product model of the 180kW DC charger is IDC180E. Here is the detailed description:

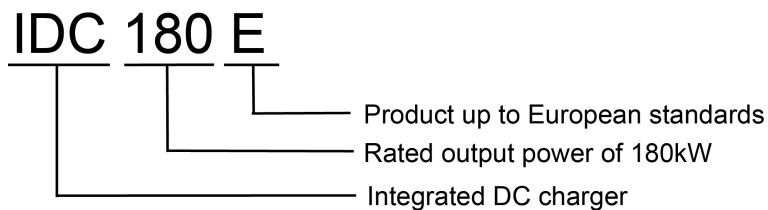

### Features

- Maximum output voltage up to 1000V , compatible with most vehicle models of today and tomorrow.

- High ingress protection rating (IP65), suitable for use in harsh environments.
- Protected against the ingress of moisture, dust, and salt spray into the device, which hence lowers the overall failure rate.
- Adopt the independent air duct design. With electronic components isolated from the outside world, the reliability and service life of the components are greatly improved, as well as the reliability of the device as a whole.
- No dust-proof fabric, no need for dust-proof fabric maintenance on the air inlet/outlet. All components and parts are selected in line with strict requirements, and the whole device runs on a refined control system. The overall failure rate is rather low, thus no regular device maintenance is required.

## 2.3 Application Scenarios

The IDC180E charger is mainly used in public charging stations for quick EV charging.

For ease of charger operation and management, two charging scenarios are provided for users to choose:

- Near-end charging: Operate the charger using an RFID card, a credit card, or its LCD display.
- Remote charging: Operate the charger through the third-party operation platform.

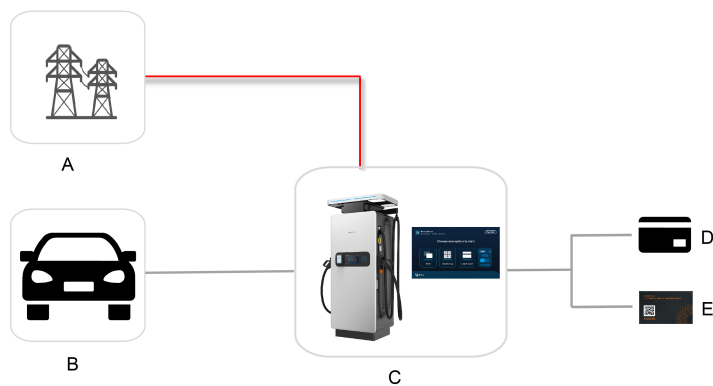

**Figure 2-2 Near-end Charging**

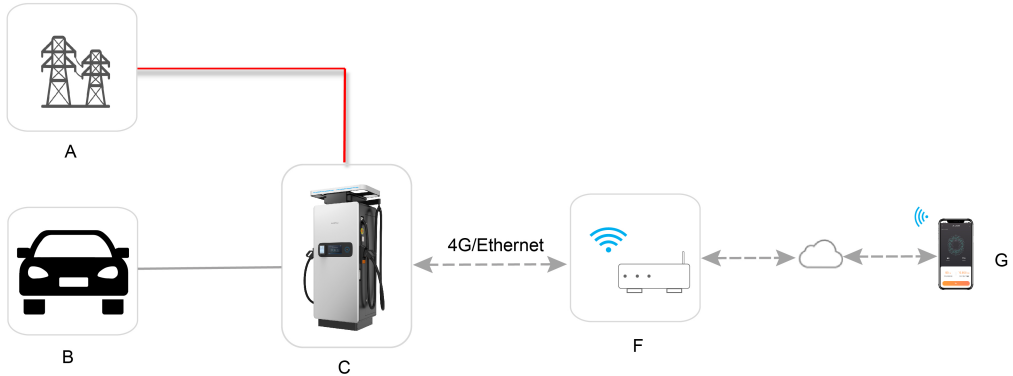

**Figure 2-3 Remote Charging**







No.	Item	Description
A	Grid	The use of IDC180E is supported in grids adopting TN-S, TN-CS, and TT earthing systems.
B	EV	—
C	Charger	IDC180E
D	Credit card	Users can start charging using IDC180E with a credit card.
E	RFID card	Users can start charging using IDC180E with an RFID card.
F	Communication base station/router	Provides stable 4G/WLAN networks for the charger.
G	Third-party operation platform	Charger operation and management platform for users.

## 2.4 Operating Principle

IDC180E is an integrated charger equipped with two charging connectors. The two charging connectors can be used separately or together at the same time. The product is composed of six 30kW charging power units and one charging control system. The charging control system is constituted by one main control unit (TCU) and two sub-control units (one for each charging connector). During charging, the output power of the charging connector A and B is:

- Connector A in use only: 180 kW (A) + 0 kW (B)
- Connectors A and B both in use: 90 kW (A) + 90 kW (B)
- Connector B in use only: 0 kW (A) + 180 kW (B)



Marks	Description
	Do not dispose of the device together with household waste.
	Read the user manual before maintenance!
	Burn hazard due to the hot surface that may exceed 60°C.
	Disconnect the device from all external power sources before maintenance!
	Danger to life due to high voltages! Only qualified personnel can open and maintain the device.
	Do not touch live parts until 10 minutes after disconnection from the sources.

## 2.6 Product Exterior

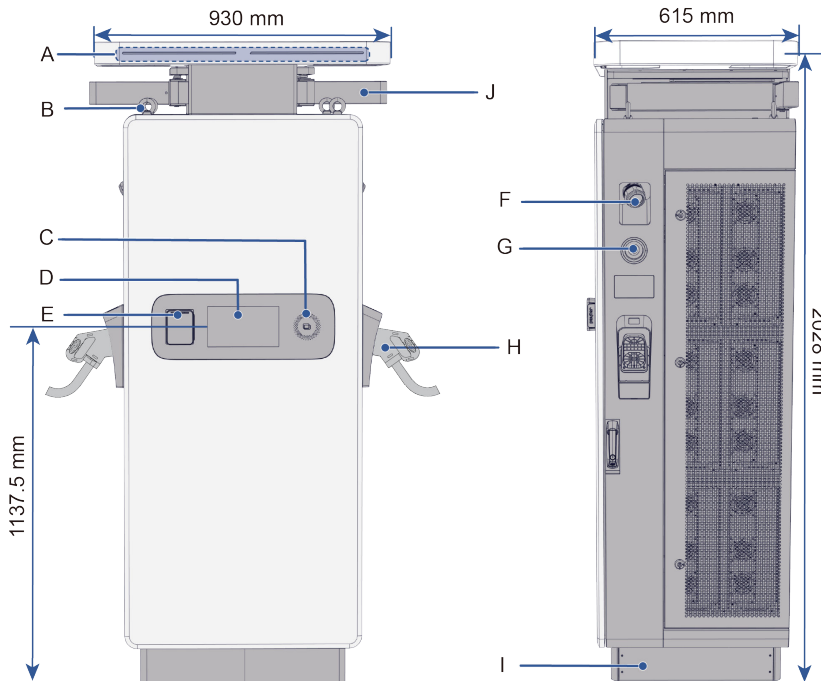

**Table 2-3 Dimensions and Weight**

Model	Dimensions	Weight
IDC180E	2028 mm x 930 mm x 615 mm	≤500 kg

**Table 2-4 Product Exterior and Interfaces**

Mark	Description
A	Top indicators
B	Lifting rings
C	Energy Star-Ring (RFID card reader)
D	LCD touch screen
E	Credit card reader <input type="checkbox"/> Optional <input type="checkbox"/>
F	Cable outlet
G	Emergency stop button
H	Charging connector
I	Base

Mark	Description
J	Cantilever

### 2.7 Internal Structure

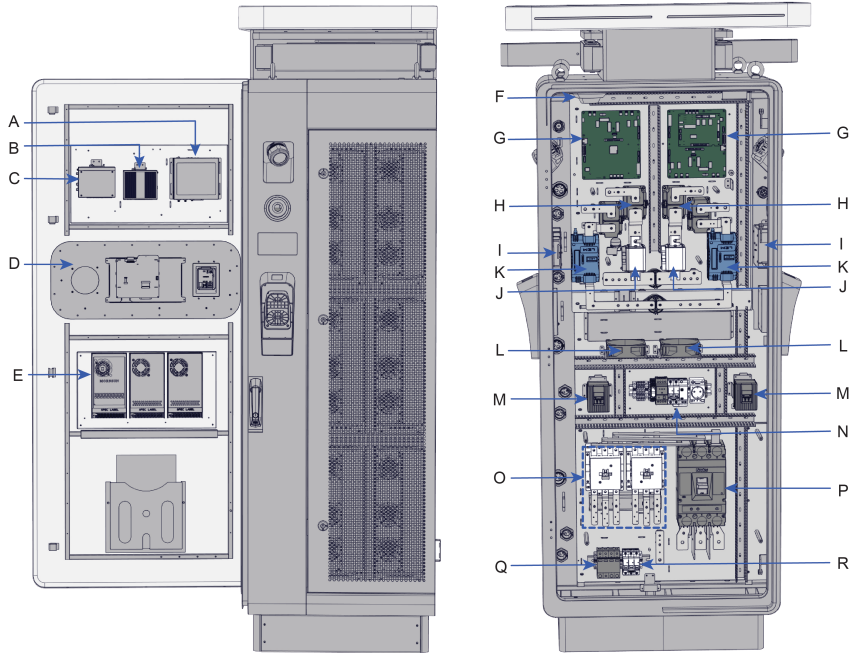

Table 2-5 Internal Structure

No.	Name
A	Toll control unit
B	Switch
C	4G router
D	LCD screen assembly
E	Switch mode power supply
F	Smoke detector
G	Charging control board
H	DC contactor
I	Meter <input type="checkbox"/> Optional <input type="checkbox"/>

No.	Name
J	Fuse
K	Shunt
L	Fan
M	Heater
N	MCB (miniature circuit breaker)
O	AC contactor
P	MCCB (molded case circuit breaker)
Q	SPD
R	circuit breaker

## 2.8 Indicators

IDC180E is equipped with two types of indicators, the top indicators, and the Energy Star-Ring on the front. The left and right top indicators indicate the status of the left and right charging connectors separately, and the Energy Star-Ring indicates the overall status of the charger.

**Table 2-6 Indicator Description**

Indicator	Indicator Status	Charger Status	Remark
Top Indicators	Steady green	The charging connector is in the standby state	Normal. The left and right indicators are independent of each other.
	Breathing blue	The charging connector is being used for charging	Normal. The left and right indicators are independent of each other.
	Steady blue	Fully charged	Normal. The left and right indicators are independent of each other.
	Steady red	Fault	Abnormal. The left and right indicators are independent of each other.

Indicator	Indicator Status	Charger Status	Remark
Energy Star-Ring	Blink blue	Waiting for the user to swipe a card and start charging	Normal.
	Steady blue	The charger is working normally	Normal.
	Steady red	There is a fault with the charger	Abnormal. If there is a fault with only one of the charging connectors, the indicator will still be steady blue.

## 2.9 Charging Cable Specifications

### Cable Working Radius

The standard charging cables included in the cable management system are 5 meters in length. The actual working radius of the cables is 3.6 meters, as shown in the figures below:

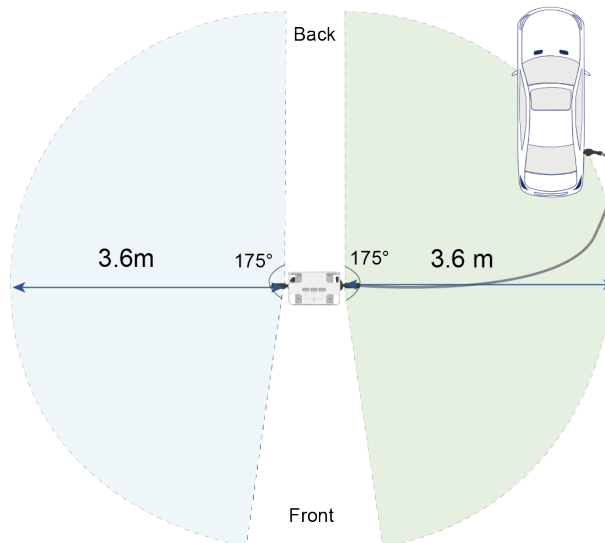
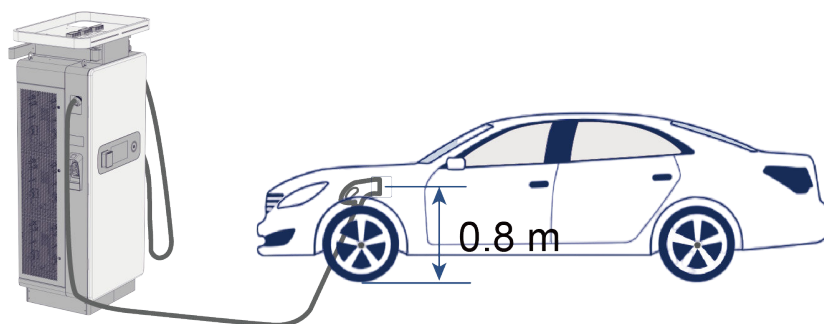

**Figure 2-5 Actual working radius of the 5-meter cable**



Ensure that there are no sharp objects within the working radius of the cable to prevent damage to its insulation and ensure proper functioning.

The 3.6-meter working radii are based on the scenario where the EV's charging port is 0.8 meters above the ground.



**i** The cable management system can effectively prevent damage caused by the cable dragging on the ground.

## 3 Installation



- Installation is supplied from a dedicated power transformer or generator, and which is not connected to low voltage (LV) overhead power lines.
- Installation is physically separated from residential environments by distance greater than 30 m or by a structure which acts as a barrier to radiated phenomena.
- This equipment complies with the disturbance voltage limit of high-power electronic systems and equipment with a rated input power of >75 kVA, and provides corresponding installation measures for installers in this manual.

### 3.1 Installation Requirements

#### Installation Environment Requirements

The device should be installed in an environment that meets the following requirements:

- The place where the device is installed must be free from flammables and explosives.
- Do not install the device in a place with corrosives such as corrosive gas and organic solvent, etc.
- The place where the device is installed and operates should be free from strong vibration, strong impact, and strong electromagnetic field interference. The external magnetic field strength should not exceed 0.5 mT.
- The place where the device is installed must be free from mediums carrying explosion hazards, without hazardous gas or conductive mediums, which may corrode the metal or damage the insulation, around it.
- Please consult SUNGROW before installing the device outdoors in areas prone to salt damage, which mainly are coastal areas within 500 meters of the coast. The sedimentation amount of salt spray is correlated to the characteristics of the seawater, sea winds, precipitation, air humidity, topography, and forest coverage in the adjacent sea areas, and there are substantial differences between different coastal areas.
- Please install the device in a place with proper temperature and humidity. The allowable temperature and humidity range are shown in the figure below:
- Please install the device in a place with proper temperature and humidity. The allowable temperature and humidity range are shown in the figure below:

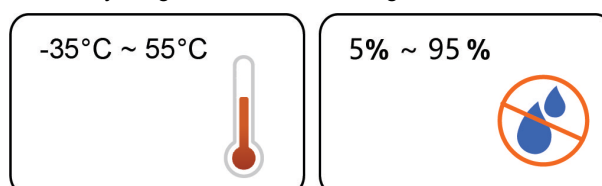

When the ambient temperature is above 45°C, it's recommended to add shading for extra protection.

- Do not install the device in dusty and smoky environments.
- It is suggested to install the device in a place with shelter, so as to prevent it from getting impacted by direct sunlight or severe weather (e.g., snow, rain, and lightning). The device will derate in high temperatures for self-protection. If installed in a place directly exposed to sunlight, as the temperature rises, the device may witness power reduction.
- Install the device in a well-ventilated place to ensure good heat dissipation.
- This device is not intended for use in residential environments and may not provide adequate protection to radio reception in such environments.
- It is recommended that the product be installed outside a 50-meter range from residential areas. When geographical conditions do not allow for a 50-meter range, noise reduction measures can be taken. For specific plans, please consult the station designers.

### Installation Space Requirements

To ensure good heat dissipation and easy maintenance, the minimum space between the device and the objects around it should not be smaller than that specified by the requirements.

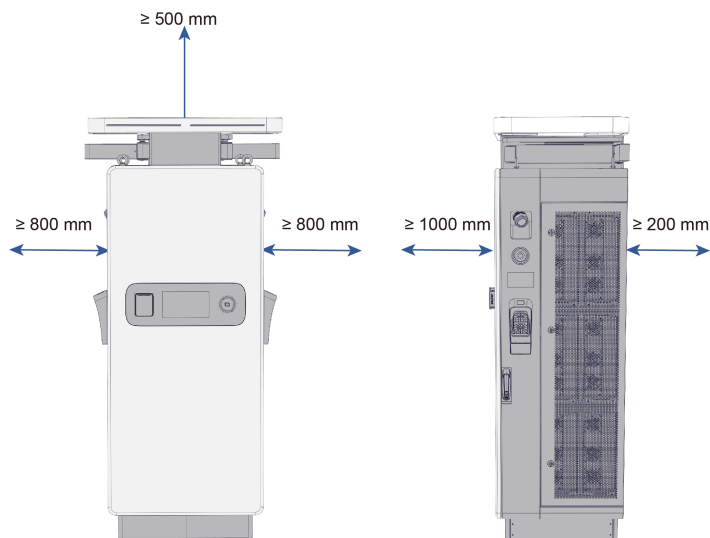
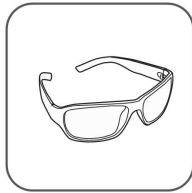

**Figure 3-1 Space Requirements for Installation**

To protect the device from direct sunlight, rain, and snow and extend its service life, it is recommended to set a rainproof shed for the device.

## 3.2 Installation Tools

Installation tools to be used include but are not limited to those listed below. If necessary, use other auxiliary tools on site.



Goggles



Safety gloves



Safety shoes



Anti-static wrist  
strap



Phillips  
screwdriver  
M6,M8,M10



Slotted  
screwdriver

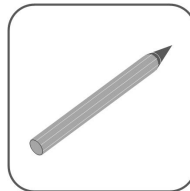

Marker



Safety helmet

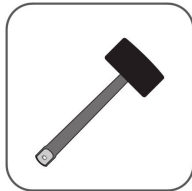

Rubber mallet



Socket wrench set  
(M6, M8, M10,  
M12)



Wire cutter



Wire stripper

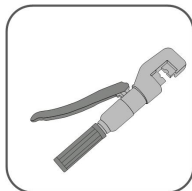

Hydraulic plier

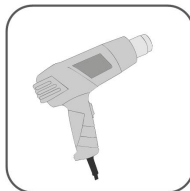

Heat gun

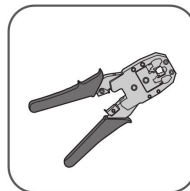

RJ45 crimping  
tool

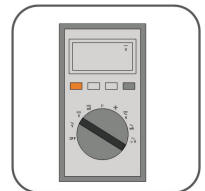

Multimeter

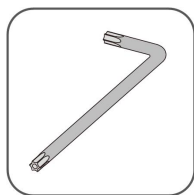

Allen wrench  
(T30)



Hammer drill  
(φ16)



Vacuum cleaner



Scissors

### 3.3 Packing List

The product has undergone thorough tests and strict inspections before delivery. However, as it may still get damaged during transport, please carry out an inspection carefully before installation.

- Inspect the packaging for any damages.
- Unpack and inspect the items inside for any damages.
- Be careful not to damage the product while using tools for unpacking.

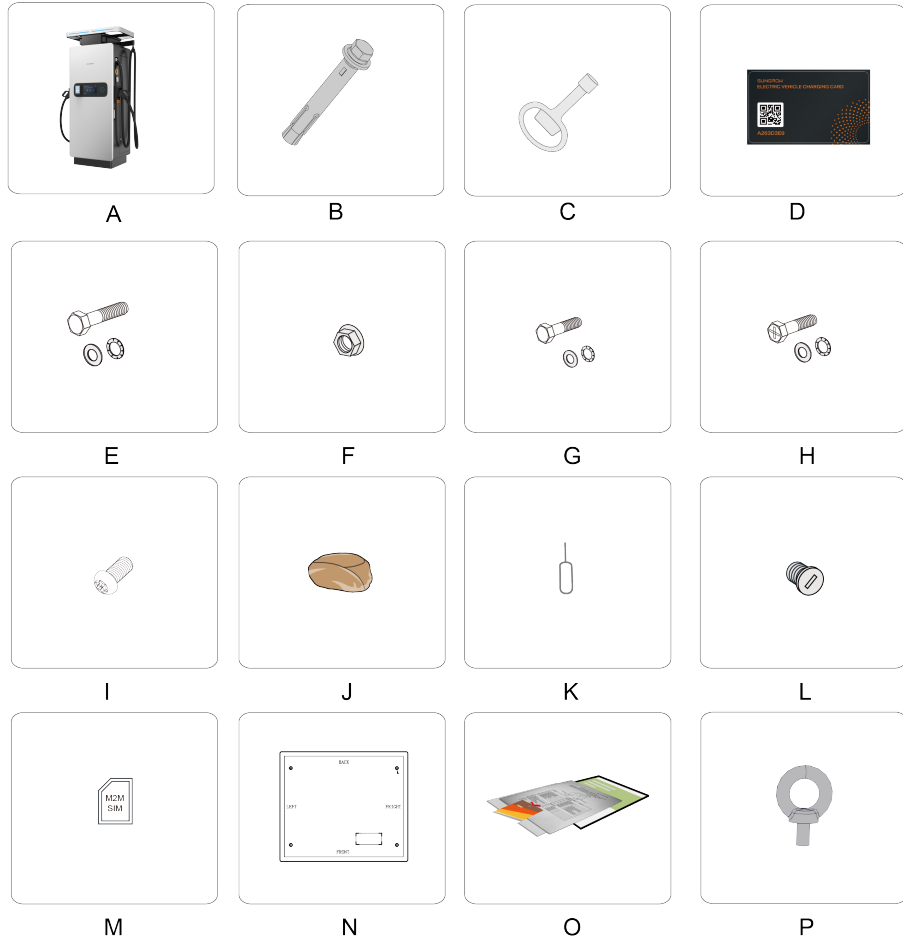

No.	Name	Quantity	Description
A	Floor-standing DC charger	1	IDC180E
B	M12×100 Expansion bolt	4	Used to fix the charger to the foundation
C	Door key	4	Used to open the front door and the left and right side doors
D	RFID card	2	Used to start charging
E	M10×25 bolt assembly	6	Used to secure the AC A, B, C phase wires and the external grounding to the terminals

No	Name	Quantity	Description
F	M10 hex flange nut	4	Used in conjunction with M10×25, to secure the AC A, B, C phase wires to the terminals
G	M8×16 bolt assembly	3	Used to secure the AC N and PE wires to the terminals
H	M6×16 bolt assembly	3	Used to secure the AC N and PE wires to the terminals
I	M5×12	3	Used to fix the cover plate at the charger bottom
J	Fireproof mud	1	Used to seal off the AC cable inlet
K	ejector pin	1	Used to install the SIM card
L	Waterproof plug	4	Used to seal off the corresponding holes accordingly after the lifting rings are removed
M	M2M_2FF 4G IoT SIM card	1	Used for communication. It should be installed inside the TCU
N	Mounting template	1	Used to determine the location of holes to be drilled on the foundation
O	Documents	-	Quick Installation Guide, certificate of conformity, warranty card, test report, packing list
P	Lifting Rings	4	Used for hoisting and transporting the charger.

In case of any damages or missing items, do not install the device. Contact your transport service provider or SUNGROW, and provide relevant photos for follow-up services.

## 3.4 Foundation Building

### Background Information

Considering its heavy weight, please fit the DC charger on a solid brick or concrete foundation to ensure its stable operation. The requirements for foundation building are as follows:

- The soil on the installation site should have a certain degree of density. It is recommended that the relative density of soil on the installation site be at least 98%. In case the soil on the site is loose, take relevant measures to make sure the foundation is stable.

- The bottom of the foundation pit must be compacted, filled and made even, so that it can provide sufficient and effective support for the product.
- The foundation should be higher than the horizontal ground to protect the product base and interior from rain erosion.
- The cross-sectional area and height of the foundation should meet the requirements.
- Cable laying should be taken into consideration when building the foundation.
- Pre-bury the conduit at the foundation bottom, according to the location of the cable inlet provided on the product.
- A drainage system is required, so as to prevent the bottom or internal components of the product from being soaked during the rainy season or a heavy rainfall.

### Preparation

- Expansion bolts: 4 pcs.

**Step 1** Set up a foundation according to the charger's dimensions.

- Build the foundation by referring to the figure below. It is recommended to keep the foundation 200 mm higher than the horizontal ground, and 100 mm larger than the charger dimensions on the front, back, left, and right.
- As shown in the figure, drill the hole for cable laying at the specified position on the foundation. The diameter of the pre-buried conduit is suggested to be 120 mm.

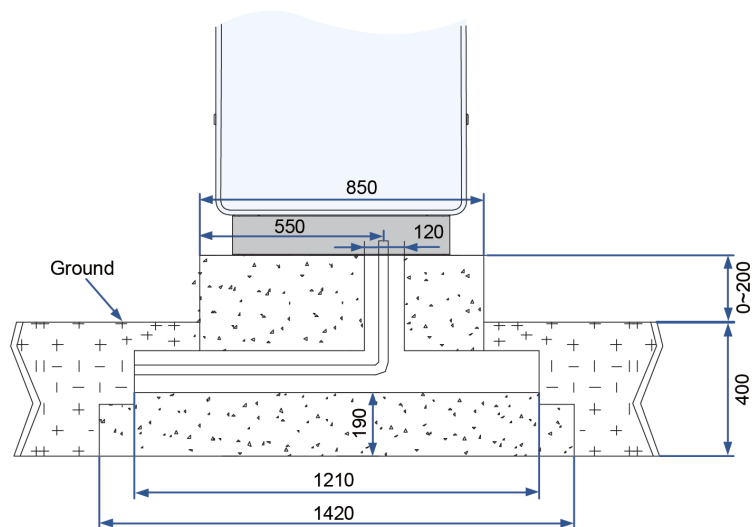

**Figure 3-2 Foundation Dimensions (mm)**

- Drill holes for expansion bolts at the specified positions on the foundation by referring to the figure below (diameter:  $\varnothing 16$ ; depth: 120 mm; specification: M12 $\times$ 100).



- When rotating the crane for unloading, keep it rotating at a low speed. Keep the product steady and as close to the ground as possible.
- Do not shake the slings during handling.
- Do not keep the product lifted up for a long period of time.
- Do not drag the product along any surface.

### Tools

Item	Requirement	Source
Crane	Load carrying capacity $\geq 3000$ kg.	Prepared by users
Slings	2 slings; each has a lifting capacity of $\geq 600$ kg. The length between the lifting ring and crane hook should be $\geq 800$ mm.	Prepared by users

**Step 1** Take out the lifting rings included in the shipping accessories and install them securely at the four corner positions on the top of the charger enclosure. Ensure the installation is firm and stable.

**Step 2** Attach the steel wire ropes to the lifting rings on the top of the charger, as shown in the figure below.

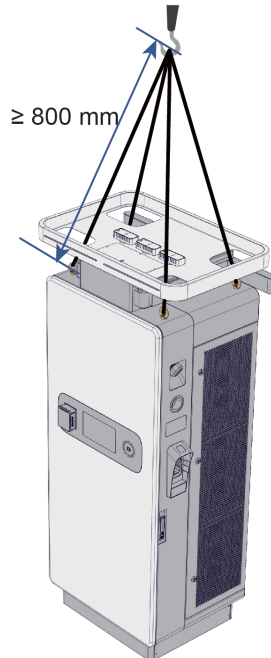

**Step 3** Hoist the charger vertically and smoothly. Make sure it is always held steady and does not tilt.

**Step 4** Suspend hoisting when the charger is lifted 100 mm off the floor. Then, check if the connection between the sling and the charger is secure and if the stress is evenly applied to the lifting points.

**Step 5** After the charger is moved over the top of foundation, lower it down steadily.

**Step 6** When the charger is fully in contact with the foundation surface, remove the wire ropes.  
--End

### 3.5.2 Handle with Forklift

#### Requirements for Handling

Read through the information below if you are about to handle the charger with a forklift.

- Use only specialized forklifts that are operated by qualified personnel.
- The carrying capacity of the forklift should meet the requirements of the product's specification.
- Make sure there are no obstacles, slopes, or other unevenness along the moving path of the product.

**Step 1** Remove the front and back sealing plates from the bottom of the charger.

**Step 2** Adjust the spacing between and height of the forklift's forks, and drive slowly forward until the forks are fully inserted under the bottom of the charger.

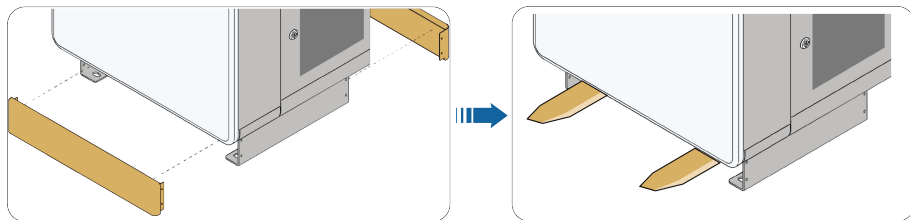

**Step 3** Pick up the charger slowly, and drive the forklift to the charger foundation at a constant speed.

**Step 4** Adjust the height of the forklift's forks until the charger is aligned with the foundation.

**Step 5** When the charger is fully in contact with the foundation surface, move away the forks slowly.  
--End

## 3.6 Electrical Connection

### 3.6.1 Preparation Before Wiring

Before proceeding with the electrical connection, prepare the cables, terminals, SIM card, and other items that are required. Cables required include the AC cable, grounding cable, and communication cable.

## Cable Specifications

Cables used for the charger should be prepared separately by users. Recommended cable specifications are listed in the table below.

**Table 3-1 Cable Specifications**

Cable	Type	Cross-sectional area (mm <sup>2</sup> )	Crimp terminal
AC cable	Outdoor five-core copper cable	L1, L2, L3, N wire: 150 mm <sup>2</sup> PE wire: 95 mm <sup>2</sup>	L1, L2, L3, N wire: SC150-10 PE wire: SC95-8
	Outdoor five-core aluminum cable <sup>(1)</sup>	L1, L2, L3, N wire: 240 mm <sup>2</sup> PE wire: 120 mm <sup>2</sup>	L1, L2, L3, N wire: SC240-10 PE wire: SC120-8
External protective grounding cable	Outdoor single-core copper cable	50 mm <sup>2</sup>	SC50-8
Communication cable	Straight-through network cable	8-core Cat5e or Cat6 Ethernet cable	-

Note(1): A copper to aluminum adapter terminal or a copper-aluminum transition connector is required when an aluminum cable is used. For details, refer to [Aluminum Cable Requirements \(Cross-sectional area ≤ 240 mm<sup>2</sup>\)](#) or [Aluminum Cable Requirements \(Cross-sectional area >240 mm<sup>2</sup>\)](#) according to the cross-sectional area of aluminum cables.



- All cable specifications listed in this manual are recommended values. Users must select appropriate cables based on actual conditions and ensure compliance with local regulations and safety standards.
- To avoid wiring errors that may cause device malfunction, it is recommended to clearly label both ends of each cable (e.g., using adhesive labels) before cable routing, and to double-check all connections before and after wiring.

## Requirements for OT/DT/SC Terminal

After the cable is led through the AC cable inlet, crimp the terminals onto the wires, so as to ensure reliable connections. Poor contact may lead to overheating or even safety incidents.

OT/DT/SC terminals (not included in the scope of delivery) are required for fixing the AC cable to the terminal block. Please prepare OT/DT/SC terminals by following the requirements below.

### OT/DT/SC Terminals of AC Cable

Specification of AC L1/L2/L3 Wires: M10

Specification of AC N/PE Wires: M8

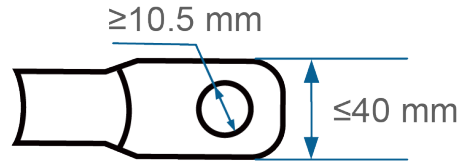

Figure 3-4 Terminal size requirements

### OT/DT/SC Terminals of external Protective Grounding Cable

Specification: M8

## 3.6.2 Crimp OT/DT terminal

### Crimp OT/DT terminal

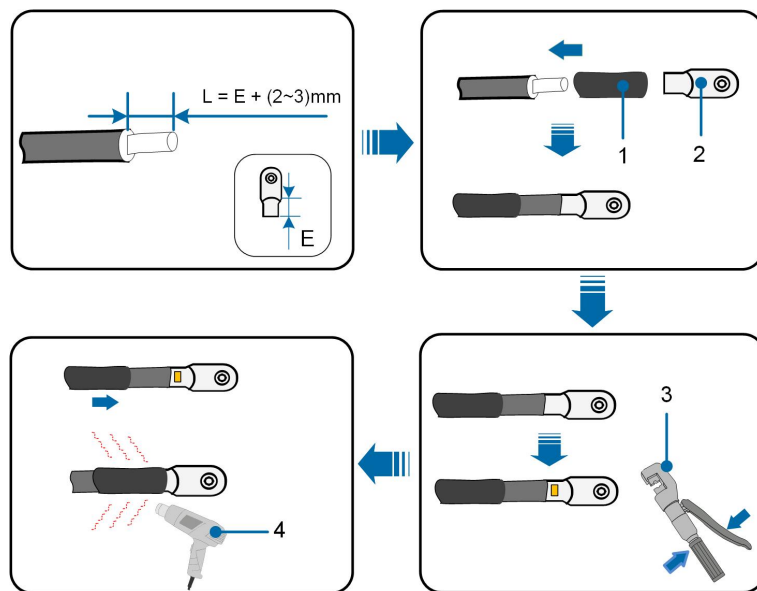

1. Heat shrink tubing

2. OT/DT terminal

3. Hydraulic pliers

4. Heat gun

### Aluminum Cable Requirements (Cross-sectional area $\leq 240 \text{ mm}^2$ )

If an Aluminum cable is selected, use a copper to Aluminum adapter terminal to avoid direct contact between the copper bar and the Aluminum cable.

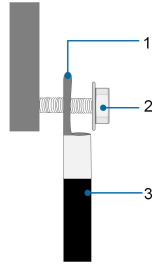

**Figure 3-5 Aluminum Cable Connection**

- |  |               |                   |
|--|---------------|-------------------|
| 1. Copper to Aluminum adapter terminal | 2. Flange nut | 3. Aluminum cable |
|--|---------------|-------------------|

**NOTICE**

Ensure that the selected terminal can directly contact with the copper bar. If there are any problems, contact the terminal manufacturer.  
 Ensure that the copper bar is not in direct contact with the aluminum wire. Otherwise, electrochemical corrosion may occur, impairing the reliability of electrical connection.

**Aluminum Cable Requirements (Cross-sectional area >240 mm<sup>2</sup>)**

When installing aluminum-core AC cables with a cross-sectional area exceeding 240 mm<sup>2</sup> in high-temperature environments, use a copper-aluminum transition connector compatible with the actual cable specifications. This converts the aluminum core cable to a copper core cable of  $\leq 240$  mm<sup>2</sup> to ensure smooth routing through the cable entry. The copper-aluminum transition connector and copper core cable are not provided and must be prepared by the user.

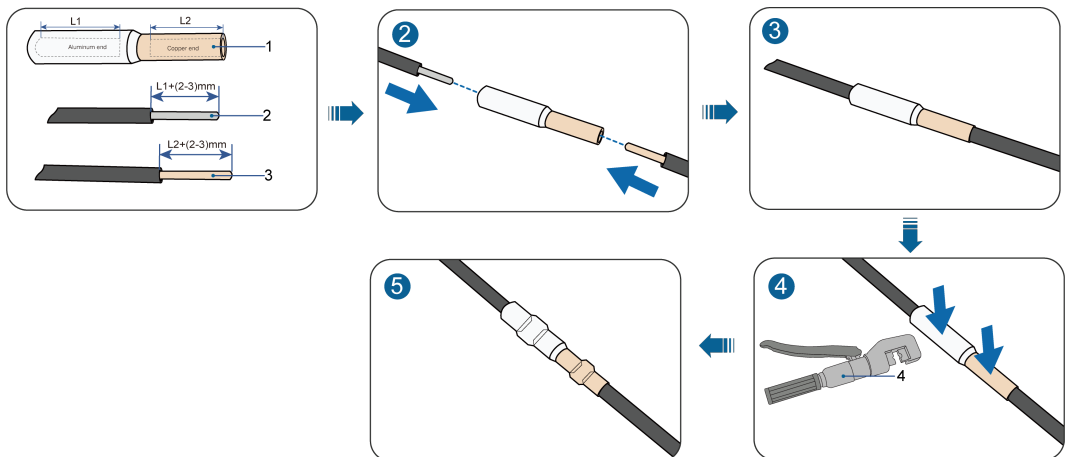

- |   |                        |
|---|------------------------|
| 1. Copper-Aluminum transition connector | 2. Aluminum core cable |
| 3. Copper core cable                    | 4. Hydraulic pliers    |



After crimping, test the connection by applying adequate pulling force to both ends of the cable to confirm secure attachment.

### 3.6.3 Protective Grounding Cable Connection

Non-current carrying metal parts and device enclosures in the electric power system should all be grounded.

The copper bar provided on the back of the charger is used for grounding. Make sure the external protective grounding cable is connected to the copper bar on the charger bottom on one side, and to ground on the other side. The grounding cable and OT/DT terminal should be prepared separately by users.

**Step 1** Make sure the charger's MCCB is set to "OFF".

**Step 2** Use wire strippers to strip the protective layer and insulating layer of the grounding cable by a proper length, by referring to the figure below.

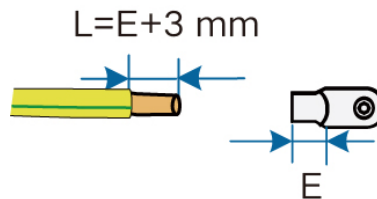

**Step 3** Prepare the cable by crimping the OT/DT terminal, as shown in the below figure.

- a. First, put the heat-shrink tubing on the stripped grounding cable;
- b. Crimp the OT/DT terminal on the cable;
- c. Finally, slide the heat-shrink tubing to cover the connection point of the cable and terminal. Then, heat the tubing to make it shrink, until it is tight against the cable underneath it.

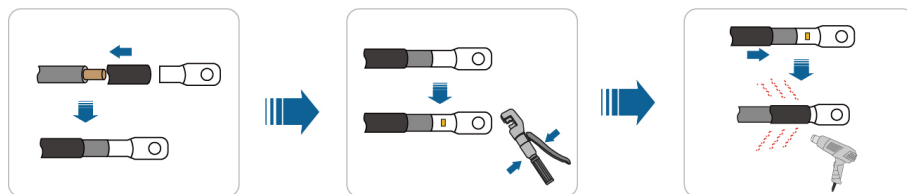

**Step 4** Connect the prepared grounding cable to the grounding copper bar on the back of the charger.

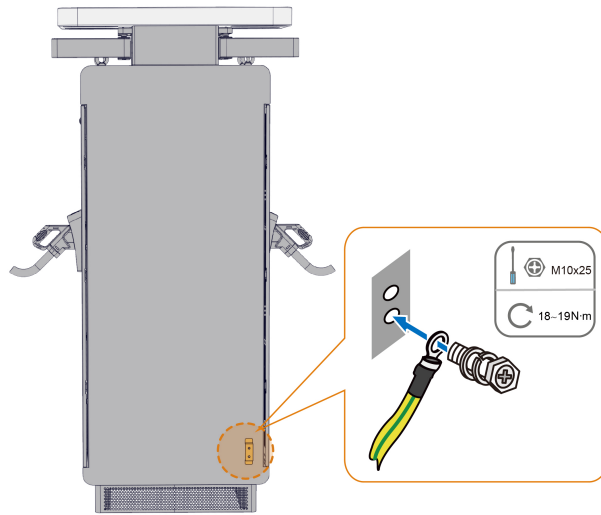

**Step 5** Make sure the grounding cable is properly and firmly connected.

**i** Two grounding copper bars are provided on the back of the charger. Please use one of them to ground the charger.

--End

### 3.6.4 AC Cable Connection

The AC cable is used to connect the charger to the grid, so that the grid can supply power to the charger.

#### Background Information

The use of IDC180E is supported in grids adopting TN-S, TN-C-S, and TT earthing systems. Where the TT system is adopted, the ground electrode should be pre-buried at a depth of over 1 meter.

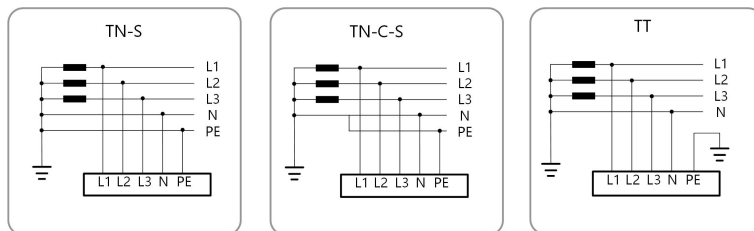

**Figure 3-6 Earthing Systems**

### **⚠ DANGER**

- Do not connect the AC cable when the device is powered on; otherwise, it may lead to personal injury.
- Do not power the charger before the AC cable connection and cable laying are all completed.



The wire colors in the figures in this manual are for reference only. Please select cables according to local cable codes.

**Step 1** Make sure the charger's MCCB is set to "OFF".

**Step 2** Open the cabinet door with the key included in the accessories.

**Step 3** Remove the screws on the waterproof sealing plate, and take the plate down.

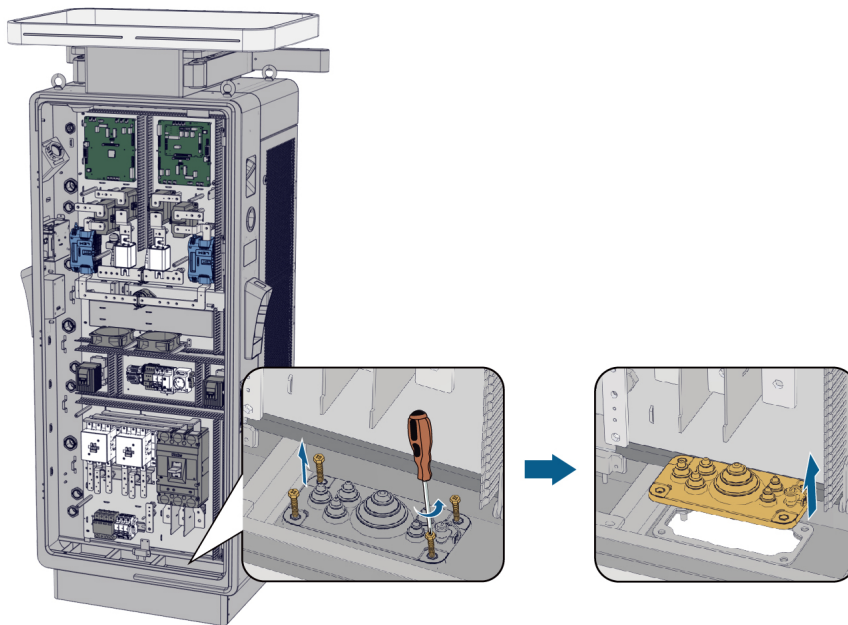

**Step 4** Trim the seal to make an opening, which should be done properly according to the outer diameter of the AC cable.

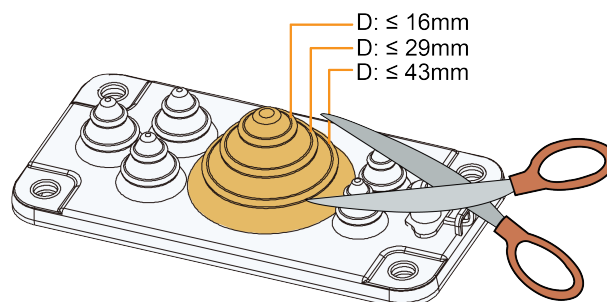

**Step 5** Use wire strippers to strip the protective layer and insulating layer of the AC cable wires by an appropriate length, by referring to the figure below.

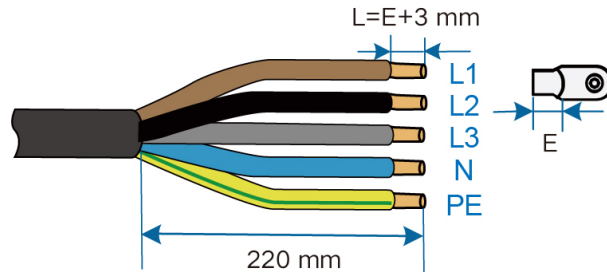

**Step 6** Crimp the OT/DT terminals onto the wires by referring to the instructions shown in the figure.

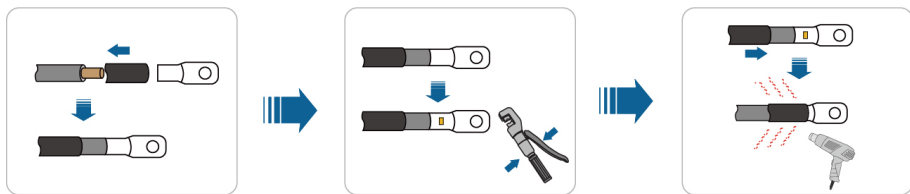

**Step 7** Lead the stripped AC cable through the cable hole on the foundation and into the AC cable inlet on the charger. Then lead it through the waterproof sealing plate.

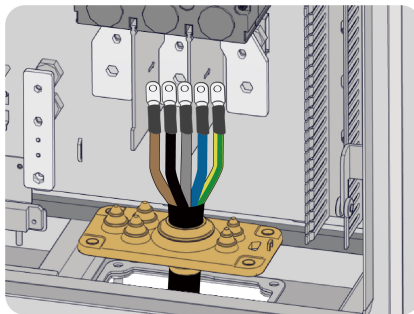

**Step 8** Mount the waterproof sealing plate back on the AC cable inlet of the charger, using the screws that are removed before.

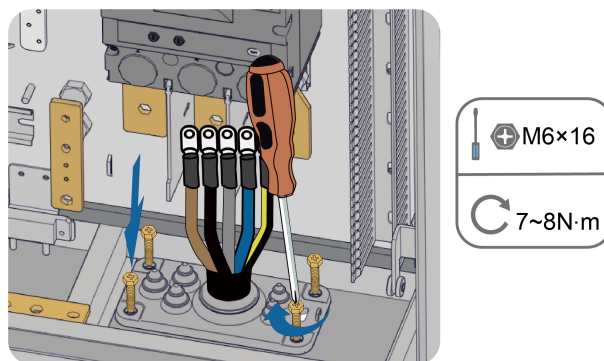

**NOTICE**

If you do not use the waterproof sealing plate that comes with the product, please seal off the cable inlets using fireproof mud or polyurethane foam.

**Step 9** Use a socket wrench to fix the wires onto the corresponding terminals.

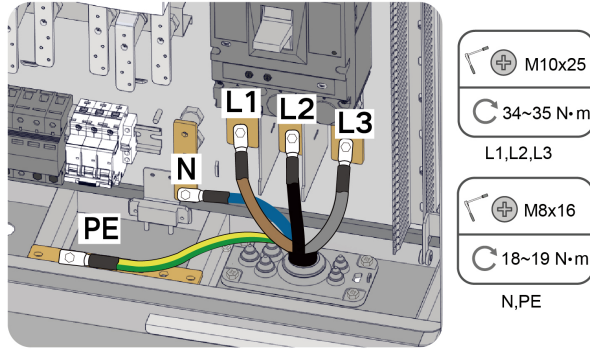

--End

### 3.6.5 Communication Interfaces

The charging management platform is a cloud platform incorporating functions of monitoring, operation, and management. Users can manage and maintain their devices on this platform, with functions such as charging authorization, order management, and remote fault troubleshooting. The device communicates with the charging management platform over the OCPP protocol. OCPP (Open Charge Point Protocol) defines the protocol standard for network interconnection between the charger and the charging management platform.

**Table 3-2 Hardware Interfaces**

Interfaces	Visible	Use Case
Ethernet interface	Y	Network Communication
4G Communication Slot	Y	4G Communication
Wifi interface	N	Communication via WiFi

**Table 3-3 Supported Communication Protocols**

Protocols	Description
HTTP+TLS	OCPP server connection; WiFi module and App connection
LTE	4G SIM card communication
Modbus	Communication based on MbedTLS

The charger operates a web service via port 8089, providing a browser-based interactive management interface. Users can access this interface to perform system management tasks, including login, network configuration, device status monitoring, OCPP protocol settings, certificate management, charging parameter configuration, system reboot, SSH service management, and data traffic monitoring.

The IDC180E can communicate with the charging management platform over 4G and Ethernet networks. The parameters required for each type of network connection are detailed in the table below.

**Table 3-4 Supported Network Connection Methods**

Communication Method	Technical Data	Connection Method
4G	Frequency Band: <ul style="list-style-type: none"> <li>• LET-FDD: Band 1/3/7/8/20/28A</li> <li>• LTE- TDD: Band 38/40/41</li> <li>• WCDMA: Band 1/8</li> <li>• GSM: Band 3/8</li> </ul> Transmitting Power: <ul style="list-style-type: none"> <li>• LET-FDD (Band 1/3/7/8/20/28A): 23dBm-2dB/23dBm+2dB</li> <li>• LTE-TDD (Band 38/39/40): 23dBm-2dB/23dBm+2dB</li> <li>• GSM (Band 3): 26dBm</li> <li>• GSM (Band 8):</li> </ul>	SIM card
Ethernet	Rate (Mbit/s): 10/100 self-adaptive	Ethernet port

During high network traffic conditions, the device will enter a protection mode and activate rate limiting measures. There are three types of protection mechanisms:

- IP-Based request rate limiting
 

Each accessing IP address is assigned a separate token bucket. Up to 10 tokens are replenished per minute, with a maximum capacity of 60 tokens. Each API request consumes one token. Once the tokens are depleted, any further requests from that IP will be directly rejected.
- Global request rate limiting
 

The system maintains a global token bucket to limit the total number of requests from all IP addresses. The global limit is set at 200 requests per minute. Any requests exceeding this limit will be uniformly rejected to prevent system overload.
- IP blacklisting mechanism
 

If an IP address repeatedly triggers request denials within a short period (i.e., continues sending requests after exhausting its tokens), the system will blacklist the IP. While blacklisted, the IP address will be denied access to all API endpoints for 5 minutes.

After the ban period ends, the system will automatically remove the IP from the blacklist, allowing access to resume.

#### Network Traffic Monitoring Panel Overview

- Start/Stop toggle: Activates or halts network monitoring.
- Monitoring indicator (green): Indicates that network monitoring is active.
- Update interval: Sets the refresh interval for the displayed data.
- Black terminal window: Displays real-time connection and traffic statistics for the current network interface (e.g., wlo1).
- Host name (port/service if enabled): Displays the hostname or IP address of the connected devices.
- => / <= Symbols: Indicate the direction of data transmission (send/receive).
- Last 2 s / 10 s / 40 s: Shows the amount of data transmitted in the past 2, 10, and 40 seconds, respectively.
- Cumulative: Displays the total traffic since monitoring activation.



Hereby, Sungrow Power Supply Co.,Ltd. declares that this radio equipment is in compliance with Directive 2014/53/EU.

### 3.6.6 Communication Cable Connection

#### NOTICE

- If you choose to connect to the internet via 4G, you will need to install a SIM card in the device. Please purchase the SIM card yourself.
- It is recommended to use a SIM card with a data plan of 500MB per month. Once the monthly data is exhausted, the device's internet connection will be disconnected. Please purchase additional data in a timely manner to restore the network connection.

The charger supports 4G and Ethernet communication, the former is a wireless communication technology while the later requires wiring. A SIM card is required to enable the 4G function on the charger; connecting the charger to a router through a communication cable is required to allow for Ethernet communication.

#### Materials required:

- SIM card: M2M SIM card, 2FF 25mm\*15mm in size.
- Recommended communication cable: 8-core Cat5e or Cat6 Ethernet cable.

\*The SIM card and communication cable should be prepared separately by the customer.

**Step 1** If you are about to adopt the wired network connection, you can follow the steps below to connect the Ethernet cable to the network port close to the charger's cabinet door.

- a. Make sure the charger's power switch is set to "OFF".
- b. Remove the sealing plug from the network port on the sealing plate.

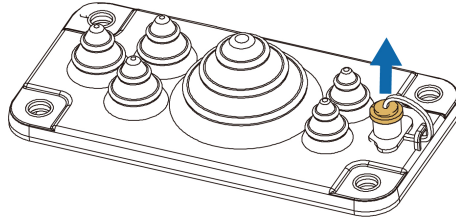

- c. Lead the Ethernet cable through the cable hole on the foundation and into the AC cable inlet on the charger. Then lead it through the waterproof sealing plate.
- d. Insert the RJ45 plug of the Ethernet cable into the network port on the charger, by referring to the instructions shown in the figure.

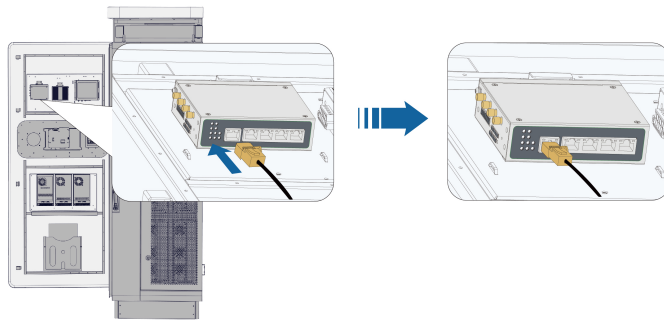

- e. Upon hearing an audible “click”, pull the network cable gently backward and make sure the connection is secure.
- f. To remove the network cable, press the tab on the RJ45 plug and pull the cable out.

**Step 2** If you are about to adopt the wireless network connection, you can follow the steps below to install the SIM card into the card slot on the inside of the charger's cabinet door.

- a. Use the ejector pin to pop open the SIM card tray.
- b. Put the SIM card on the card tray and align it with the card slot on the charger, following the direction indicated in the figure below.

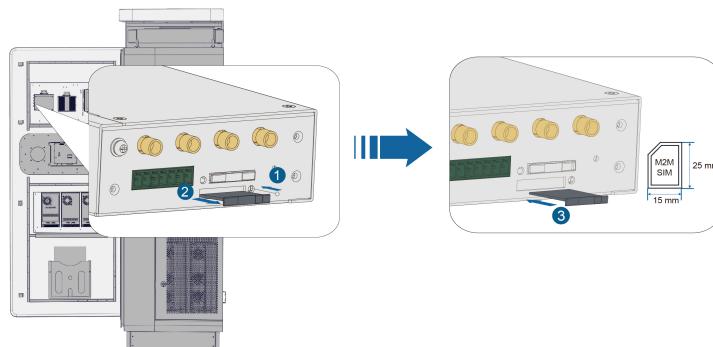

- c. Push the SIM card tray gently into the slot until it is in place. Do not exert too much pressure, so as to avoid card deformation or damage.

--End

# 4 Commissioning

## 4.1 Inspection Before Commissioning

To ensure safe use, please perform the following inspections on the device before powering it on.

**⚠ CAUTION**

Do not power the device unless the inspections are completed.

**Table 4-1 Inspection Items**

Item	Methods/ Tools	Requirements
Device inspection	Visual Inspection	<ul style="list-style-type: none"><li>• No visible scratch on or deformation on the enclosure.</li><li>• No paint peeling on the exterior.</li><li>• The parts and components of the device are secure and reliable, and the nameplate and marks are all legible.</li><li>• The device is installed in an environment where heat can be well dissipated, without any clutter piled on its top or around it.</li></ul>
Charging connector inspection	Visual Inspection	<ul style="list-style-type: none"><li>• No wet spots or foreign matters on the charging connector.</li><li>• The charging cable is intact.</li></ul>
Power supply cable inspection	Multimeter/ screwdriver	<ul style="list-style-type: none"><li>• The three-phase power supply cable is securely attached to the MCCB.</li><li>• The grounding cable is securely and properly connected to allow for effective grounding.</li><li>• The screws for the input cable are fastened.</li><li>• Check if there is short-circuit in the AC/DC circuits using a multimeter.</li><li>• Check if the supply voltage is within the input voltage range allowed for the device using a multimeter.</li></ul>

Item	Methods/ Tools	Requirements
Electric vehicle (EV) inspection	Visual Inspection	<ul style="list-style-type: none"> <li>The EV is parked in the designated place.</li> <li>The EV sits perfectly still.</li> </ul>

## 4.2 Commissioning Procedure

Perform commissioning first before using the charger to charge the EV. At the first commissioning upon powering on, users can check whether the charger has been properly installed and whether the charger software can function properly. Before powering on and commissioning, make sure all pre-commissioning inspection items meet the requirements.

### **⚠ DANGER**

- Do not touch any live part of the product when it is running; otherwise, it may lead to electrical shocks.
- Do not touch any wiring terminal on the product when it is running; otherwise, it may lead to electrical shocks.
- Do not remove any part or component from the product when it is running; otherwise, it may lead to electrical shocks.

**Step 1** Switch on the AC circuit breaker between the charger and the grid.

**Step 2** As per the instructions in the figure, switch on the circuit breakers.

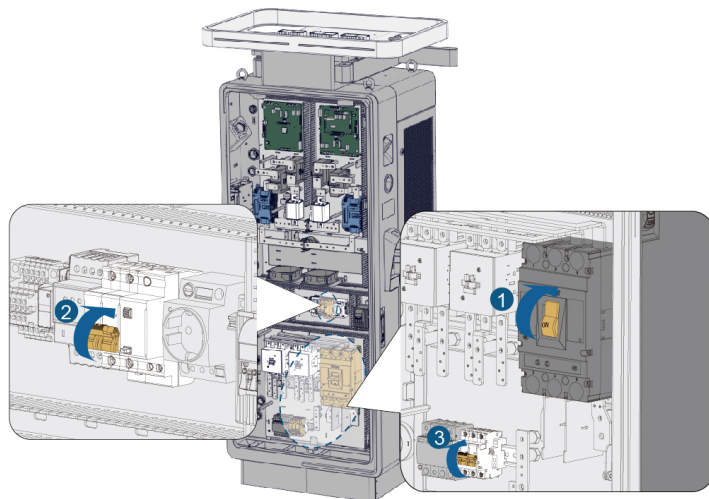

- Step 3** Close the door of the charger. Check the indicators. If the top indicator is steady green, the charging connector is in standby mode; if the Energy Star-Ring is steady blue, the charger is working normally.
- Step 4** Then check the LCD screen. The system will run a self-check, which takes about 30 seconds.

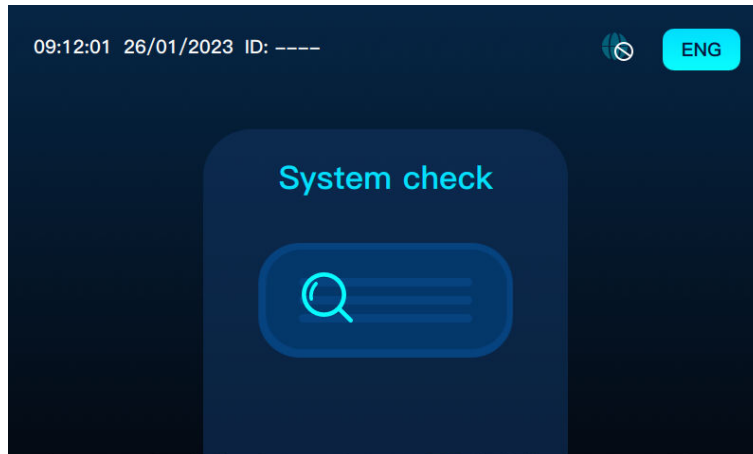

- Step 5** After the system check is finished, you can touch any area on the screen to enter the initial view.
- Step 6** Enter the factory mode. For details, see [#unique\\_40](#).
- Step 7** The first time the charger is started, you will need to complete the network configuration and OCPP configuration for the charger. For details, see [#unique\\_41](#) and [#unique\\_42](#).
- Step 8** After completing the configuration, restart the charger. You need to wait 30s after switching off the miniature circuit breaker and then switch it on again.
- Step 9** At this time, you will go to the interface for charging method selection, where you can select a charging method as needed.

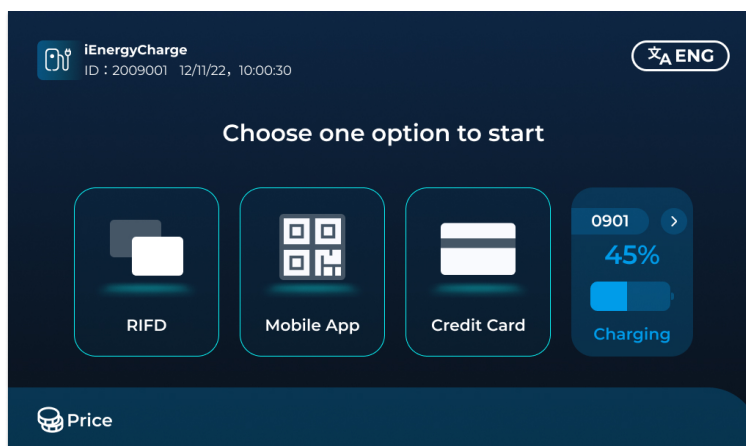

- Step 10** Taking the RFID card as an example, if you choose "RFID", the Energy Star-Ring on the device will blink blue, waiting for you to tap a card over the reader. Upon detecting the

card, the system will verify its validity. If it is valid, a successful authentication notification will show up, and you will then go to the interface for charging connector selection.

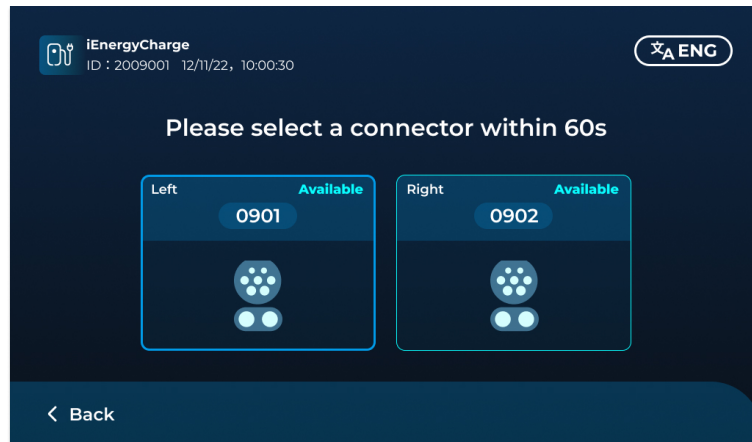

- Step 11** Take down the charging connector you have selected, and plug it into the charging port on the EV. Make sure the connection is secure.
- Step 12** After the charging is completed, insert the charging connector back into the charger, and prevent it from getting in contact with heat, dirt, or water.



In case of an emergency, you can press the emergency stop button on the side of the charger to stop charging immediately.

--End

---

## 5 LCD Touch Screen

### 5.1 Start Charging

The charger's touch screen serves as an interface for human-machine interaction. You can perform various operations on the device via the touch screen, e.g., starting or stopping charging, viewing the charging data, and performing fault diagnosis.

The flow chart of a charging session is shown as follows:

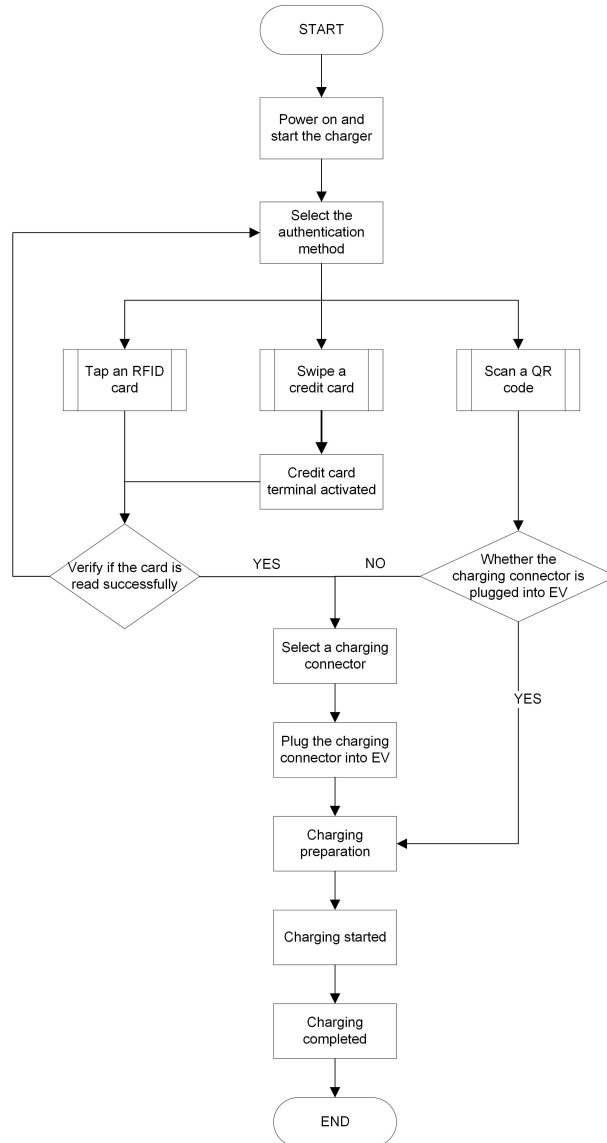

### 5.1.1 Select an Authentication Method

When powered on for the first time, the system will run a self-check automatically, and then show the interface for authentication method selection if nothing abnormal.

Three authentication methods are available for this device. You may choose based on your actual needs:

- RFID card
- Credit card
- QR Code

**Step 1** Once the system check is completed, you will go to the home page. Different authentication methods lead to different charging processes.

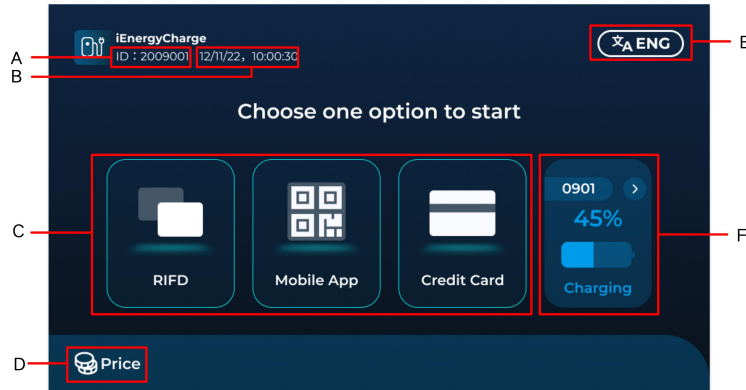

**Table 5-1 Home Page Introduction**

No.	Description
A	Charger ID, an unique identifier for the charger.
B	Current date and time.
C	Indicates the available authentication methods. You can select the RFID card, QR code, or credit card by tapping their icons here.
D	Indicates the price. The default price and member price will be shown.
E	Language switch button.
F	<p>Indicates the status of the charging connectors. The status of connectors A and B will be shown separately. You can tap  to switch between them. The status of the charging connector includes:</p> <ul style="list-style-type: none"> <li>• Available: The connector is currently available.</li> <li>• Connected: The connector has been connected to the EV.</li> <li>• Preparing: The charging is in preparation.</li> <li>• Charging: The connector is being used for charging.</li> <li>• Stopping: The connector has stopped charging.</li> <li>• Complete: The connector has finished charging.</li> <li>• Fault: The charging connector is not available due to a fault.</li> <li>• Disable: The charging connector has been disabled.</li> </ul>

**Step 2** By tapping **RFID**, you will go into the process of charging the EV with an RFID card.

- a. In this process, the system will verify if you have tapped a card over the reader. Upon detecting the card, the system will verify its validity. If it is valid, a successful authentication notification will show up, and you will then go to the interface for charging connector selection.



- b. If the authentication fails as the card is not activated or gets demagnetized, a failed authentication notification will show on the screen. You can tap **Back** to go to the previous step and select another authentication method.

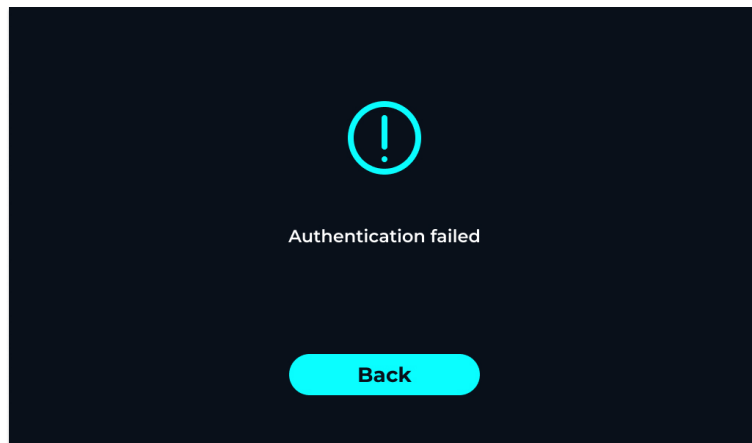

**Step 3** By tapping **Credit Card**, you will go into the process of charging the EV with a credit card.

- a. In this process, the credit card terminal will be activated by the system. Then, a message will show up, reminding you to swipe your credit card for authentication by following the instructions. If authentication has passed, you will go to the interface for selecting a charging connector.



- b. If the authentication fails as the card is not activated or gets demagnetized, you can tap **Credit Card** to go to the previous step and select another authentication method.

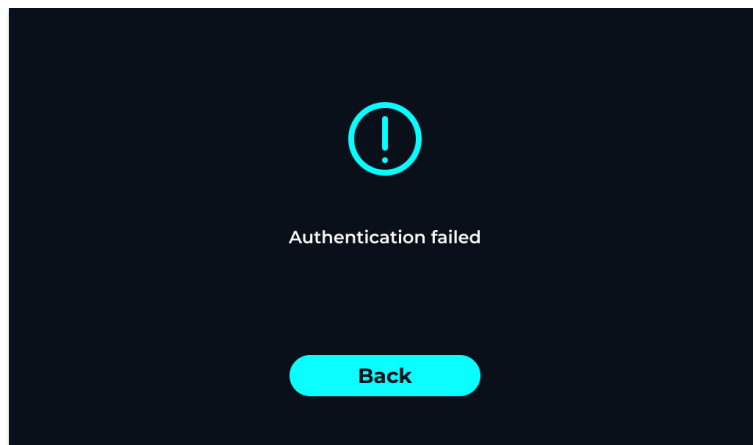

- Step 4** By tapping **Mobile App**, you will go into the process of charging by scanning a QR Code. In this process, you can use the App of the third-party operation platform on your phone to scan the QR code, or enter the charger ID, and then go to the interface for selecting a charging connector.

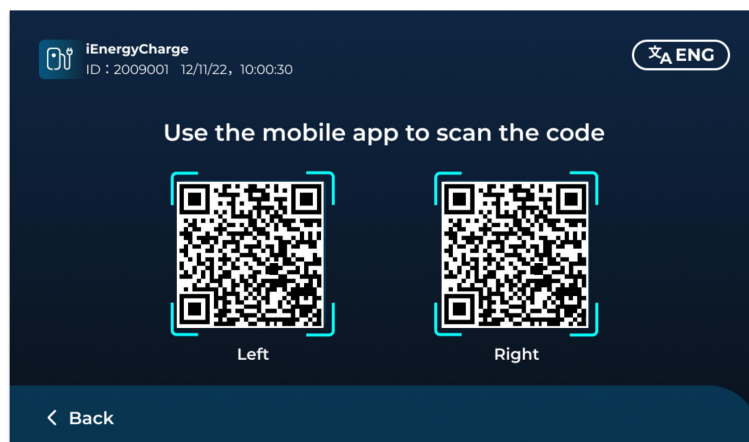

--End

### 5.1.2 Select a Charging Connector

The charger is equipped with two charging connectors and they can be used at the same time. You can select one according to the connector status.

The status of the charging connector includes:

- Available: The connector is currently available and not connected to any EV.
- Connected: The connector is available and has been connected to the EV.
- Occupied: The connector is now occupied. For a charging connector in the "Preparing", "Charging", "Stopping", or "Complete" state, its status here will show as "Occupied" and it will not be available for use.
- Unavailable: The connector is currently not available. For a charging connector in the "Fault" and "Disable" state, its status here will show as "Unavailable" and it will not be available for use.

**Step 1** Tap an RFID card or swipe a credit card. If the card is verified to be valid by the system, you will go to the interface for selecting a charging connector. The interface is shown below.

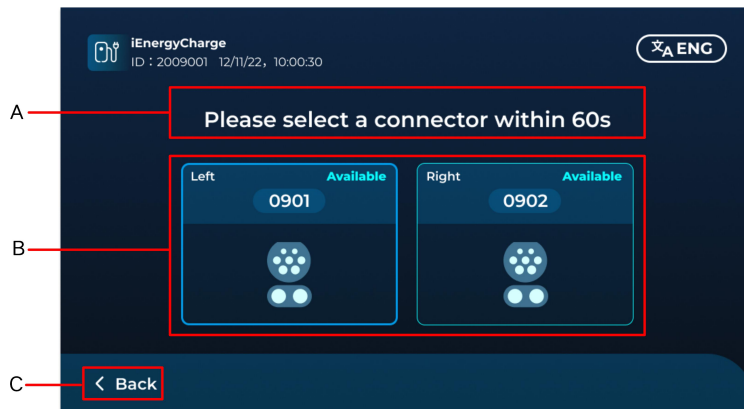

**Table 5-2 Interface for Selecting a Charging Connector**

No.	Description
A	A notice for users to select a connector within a certain period of time, with a countdown provided. After the countdown ends, the current charging session will be canceled and you will be directed back to the home page.
B	Shows the charging connectors and their status. The status of the charging connector includes: <ul style="list-style-type: none"> <li>• Available: The connector is currently available, not connected to any EV.</li> <li>• Connected: The connector is available and has been connected to an EV.</li> </ul>

No.	Description
•	Occupied: The connector is now occupied. In this case, the current charging power and the time spent in charging, in the format of HH:MM (hour:minute), will be shown on the screen.
•	Unavailable: The connector is currently not available.
C	Cancel the current charging session and go back to the interface for authentication method selection.

**Step 2** You can select a connector that is “Available” or “Connected” before the countdown ends, and then go to the interface for plugging in the connector.

**Step 3** If you want to quit selecting a connector before the countdown ends, tap **Back** to cancel the current charging session. You will then go back to the interface for authentication method selection.

**Step 4** If you have not selected any connector when the countdown ends, the system will automatically cancel the current session and go back to the interface for authentication method selection.

--End

### 5.1.3 Plug Connector for Charging

Please note the following items when plugging in the charging connector:

#### NOTICE

- Plug or unplug the charging connector neatly at one go. Do not shake it.
- Do not bend or squeeze the charging connector, which may result in mechanical damage.
- Do not pull out the charging connector in the middle of a charging process.

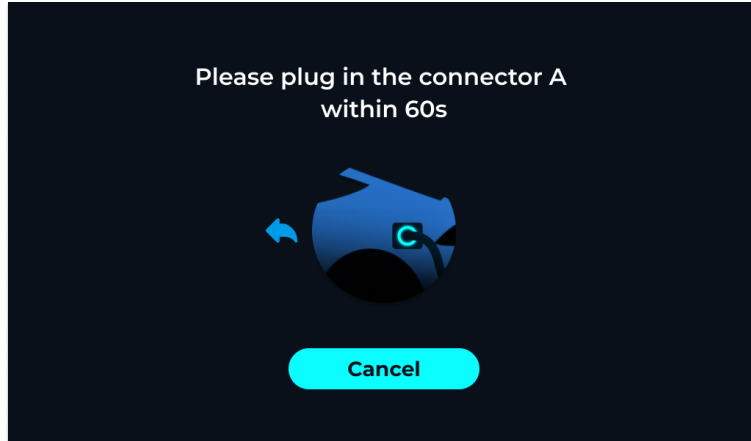

**Step 1** After a connector is selected, a notice will appear on the screen, asking you to plug in the connector within a specific period of time, as shown below. By tapping **Cancel**, you can quit this process and go back to the interface for charging connector selection.

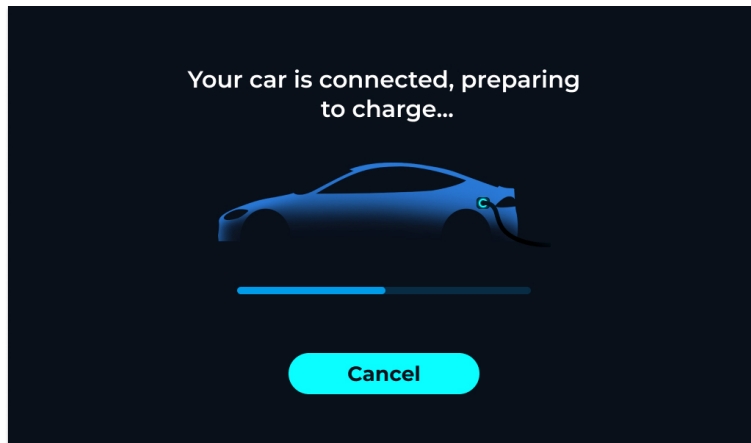

**Step 2** Plug in the connector before the end of the countdown. Upon detecting that the connector is plugged into the port, the system will go into the preparation process. You will see the below interface. By tapping **Cancel**, you can quit the process immediately.



**Step 3** Once prepared, the charging process will be started. You will then see the below interface.

The charging information will be shown on this interface. You can tap  and  to switch between the two views. See the table below for more details.

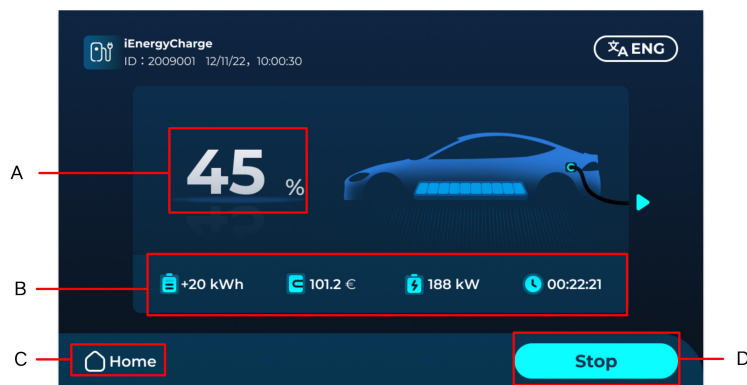

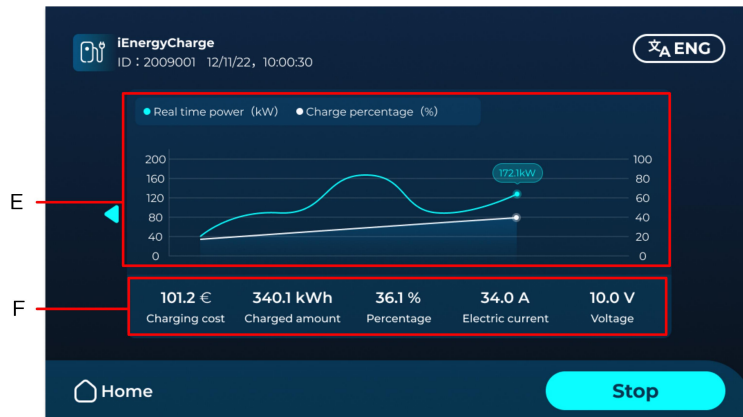

**Table 5-3 Charging View**

No.	Description
A	Progress of charging (%).
B	Charging details, including the charging power (kW), charging cost, power delivered (kWh), and time spent in charging (HH:MM:SS).
C	<b>Home</b> button. You can tap this button to go to the home page without stopping the charging process.
D	Stop charging button. You can tap this button, confirm your action by swiping a card, and go to the interface for ending the charging process.
E	A chart that shows the real-time charging power and progress.
F	Charging details, including the charging cost, amount of power delivered (kWh), charging progress (%), charging current (A), and charging voltage (V).

**Step 4** You may tap **Stop** in the middle of a charging process to stop charging immediately. Otherwise, the system will stop charging automatically when the EV is fully charged.

--End

#### 5.1.4 End a Charging Process

You can stop charging in the middle of a charging process manually, or wait for the system to stop charging automatically when the EV is fully charged.



Pull out the charging connector after the charging session has ended; otherwise, the connector will stay in the "Complete" state and cannot be selected again.

**Step 1** When the EV is fully charged, or if you stop charging manually, the below interface will be shown.

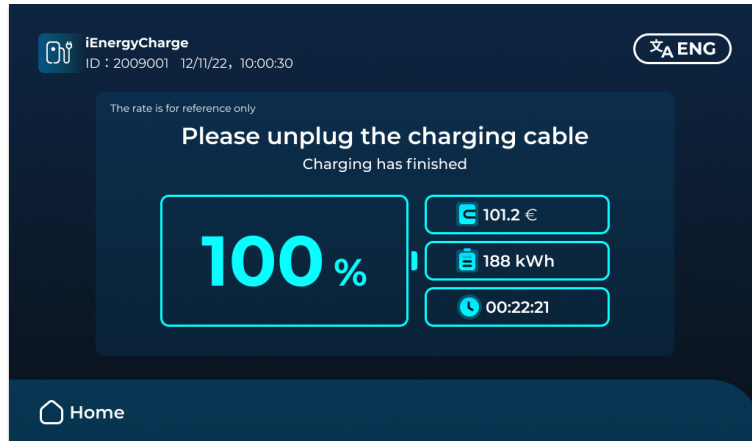

**Step 2** You can tap **Home** to go back to the home page.

--End

## 5.2 Other Functions

### 5.2.1 Switch Between Connectors

The charger's two charging connectors can be used at the same time for two independent charging sessions. Therefore, there might be two charging sessions running in the system. After finishing the settings for one connector, you can tap **Home** to go back to the home page and start setting up another one. You will only leave the current process, without stopping charging.

**Step 1** On the charging view, tap **Home** to go back to the home page, and start another charging session using the other connector.

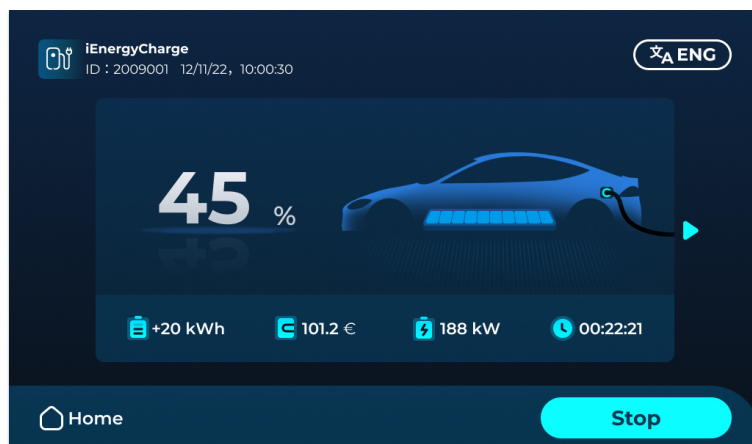



If you started charging with an RFID or credit card, you can swipe your card on the authentication method selection interface. Then, the system will go back to the previous charging session.

--End

### 5.2.2 Change System Language

The system supports languages including English, Dutch, German, French, Spanish, Norwegian, and Italian, with English as the default system language. You can switch to another language as needed.

**Step 1** Tap the language switch button at the top right on any interface, and all supported languages will be displayed on the screen, as shown below.

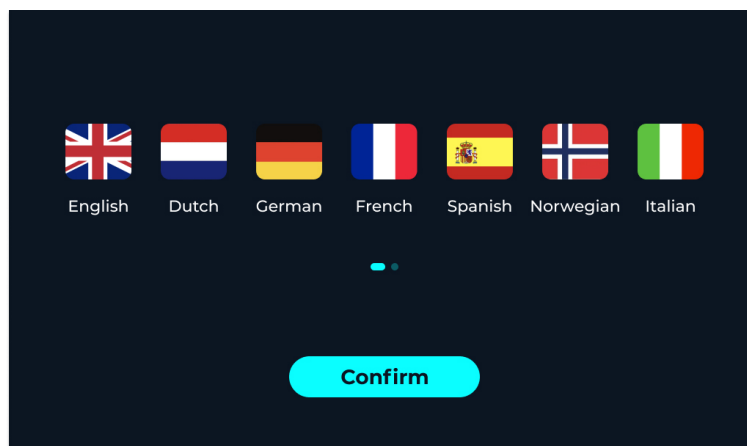

**Step 2** Select a new language and tap **Confirm**. The system language will then be changed.

--End

### 5.2.3 Emergency Stop

In case the charging process has to be stopped midway due to an emergency or a fault, press the emergency stop button on the side of the charger to stop charging immediately. The device will not work once the emergency stop button is pressed.

**Step 1** Press the emergency stop button on the side of the charger, and the charger will stop running.

**Step 2** After the emergency or fault is cleared, you can reset the emergency stop button and get the charger restored to normal status.

--End

### 5.2.4 Device Fault Diagnosis

When the system detects a device failure, the device will enter the fault state. The device cannot work in the fault state, and will not react when you plug in the charging connector.

**Step 1** When the system detects a charger failure, the charger will enter the fault state. And the detailed information about the fault will be shown on the screen.

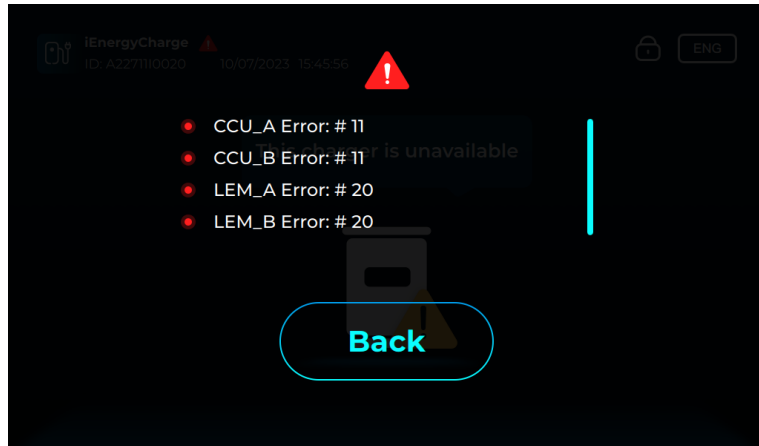

**Step 2** You can tap **Back** to close the details window. By tapping the red fault icon , you can re-open the details window to check the fault information.

--End

### 5.2.5 Network Connection Diagnosis

OCPP defines the protocol standard for network interconnection between the charger and the charging management platform. The device accesses to OCPP via network connection. In case of a network error, the device cannot access to OCPP.

Network error may arise no matter which state the device is in. A network error icon will show on the screen in case of anything abnormal with the network, and disappears after the network has restored to normal status. The abnormal status includes:

- Network connection is normal, but the device cannot access to OCPP.

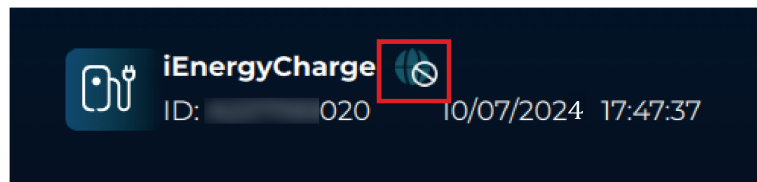

- No network connection, and the device cannot access to OCPP.

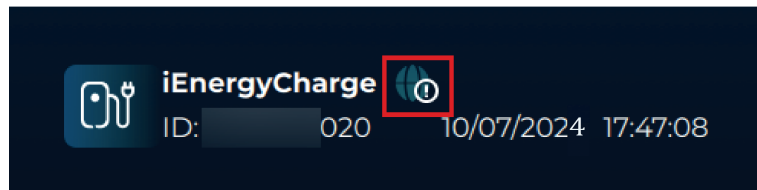

## 6 iEnergyCharge App

iEnergyCharge App is a tool that allows users to operate and manage their EV chargers. Users can complete account settings and charger configuration, manage charge cards, operate the charger, and reach customer service on the App.



Depending on the version of iEnergyCharge you are using, the user interface might be slightly different.

### 6.1 Download and Installation

#### Operating System:

- Android 6.0 or later
- iOS 11 or later

#### Option 1

Download the App from the below application stores and install it on your device:

- Google Play
- App Store

#### Option 2

Scan the QR code below, and download and install the App by following the onscreen instructions.



### 6.2 Sign-up and Log in

**Step 1** Open the iEnergyCharge App, and tap **Sign up**.

**Step 2** Enter an email address, and tap **Next**.

**Step 3** Find the verification code sent by the system in your email inbox. Then, go back to the App, enter the verification code, and tap **Next**.

**Step 4** Enter a password, and the sign-up process is now completed. You will then go to the App's **Home** screen.

--End

## 6.3 Add a Charger

To add a charger to your account on the iEnergyCharge App for operation and management.

**Step 1** Tap **Add device** on the **Home** screen. You may scan the QR code on the side of the charger, or enter the charger S/N to add a charger to your account.

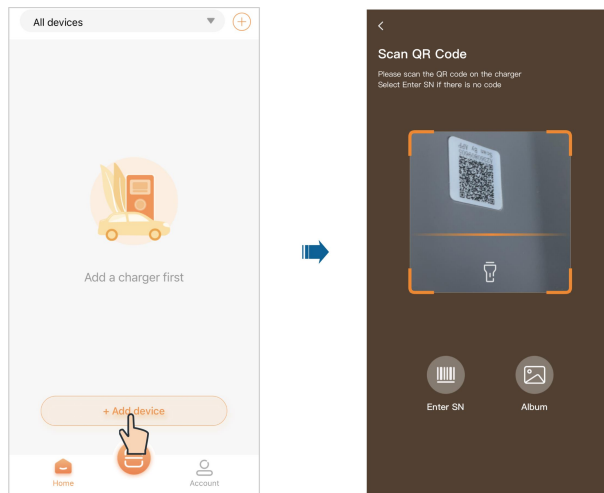

--End

For more detailed information regarding the use of iEnergyCharge App, see [iEnergyCharge User Manual](#). You can also open the App and choose **Account > Settings > User Manual** to view the manual.

# 7 Routine Inspection

## 7.1 Inspection Instructions

It is suggested to perform regular inspections on the device, so as to extend its service life. The inspection interval should be determined with on-site conditions taken into consideration. In case the device works in extreme weather conditions, be sure to shorten the inspection interval and increase inspection frequency.

- Before inspection, power off the charger. For details, see [8.2 Power Off Charger](#). Then, you may open the cover plate for inspection.
- In case of a fault with the device, contact your local service provider or manufacturer immediately. Do not open the device without permission.
- If some devices need to be replaced during the inspection, please contact SUNGROW.
- Losses caused by failing to perform inspections in compliance with the instructions specified in this manual will not be covered by the warranty.
- Do not perform inspections on the device on rainy, humid, or windy days. SUNGROW shall not be held liable for any possible outcome resulted from inspections in such weather conditions.
- To reduce the risk of electric shocks, do not perform inspections that are not specified in this manual. If needed, please contact SUNGROW for inspection and repair services. Otherwise, damages caused therefrom will not be covered by the warranty.

## 7.2 Routine Inspection

It is recommended to perform routine inspections on the device once every 6 months. However, the actual inspection interval is subject to the operating environment.

Inspection Item	Inspection Method	Recommended Inspection Interval
Device exterior	<ul style="list-style-type: none"><li>• Check if there is any deformation with the enclosure of the device.</li><li>• Check if there is paint peeling on the exterior of the device.</li><li>• Check if the nameplate and marks on the device are all legible.</li><li>• Check if there is anything abnormal with the exterior of peripheral</li></ul>	Once every 6 months

Inspection Item	Inspection Method	Recommended Inspection Interval
	<p>components such as the charging connector holder and antenna.</p>	
Device structure	<ul style="list-style-type: none"> <li>• Check if the parts and components of the device are secure and reliable.</li> <li>• Check if there is any damage to the internal power units, main control board, auxiliary low-voltage power supply, charging interface, and power supply interface.</li> <li>• Clean the dust-proof fabric and dirt and dust inside the device, and check if there is any wet spot.</li> </ul>	Once every 6 months
Charging connector and charging cable	<ul style="list-style-type: none"> <li>• Check the charging connector for any foreign matters. Ensure the pins inside the connector are clean without dirt. Clean off the foreign matters, if any, in time.</li> <li>• Check the charging connector and charging cable for deficiency, crack, abrasion, damage, wire exposure, etc.</li> <li>• If the charging connector freezes to the dispenser, it is recommended to carefully remove the ice with a cordless heat gun and a plastic scraper. During the heating process, please ensure that the temperature does not exceed 60°C and continuously move the heat gun back and forth to prevent damage to the charging connector or cable due to overheating.</li> </ul>	Once every 6 months
Electrical connections	<ul style="list-style-type: none"> <li>• Check if the electrical line is burnt or has aged and if the fixing screws are loose.</li> <li>• Check whether the grounding cable is properly connected to allow for reliable grounding.</li> <li>• Check the cables for deficiency, crack, abrasion, damage, wire exposure, etc.</li> </ul>	Once every 6 months

Inspection Item	Inspection Method	Recommended Inspection Interval
	<ul style="list-style-type: none"> <li>Other inspection items can be arranged based on the actual situation on the site.</li> </ul>	
LCD screen	<ul style="list-style-type: none"> <li>Check the display of the screen for broken or cracks.</li> <li>Check the brightness of the screen and whether the display definition is normal.</li> <li>Click the screen to operate and check whether the touch function is normal.</li> <li>Check the waterproof performance around the screen and the plastic panel.</li> </ul>	Once every 6 months
Fan	<ul style="list-style-type: none"> <li>Check the fan and the fan opening for any foreign matters, and remove them promptly if found</li> <li>Check whether the fan is operating normally during runtime.</li> </ul>	Once every 6 months

# 8 Troubleshooting and Maintenance

## 8.1 Troubleshooting



In case of a fault with the device, please contact your local service provider or manufacturer immediately. Do not open the device without permission.

**Table 8-1 Charging stop code**

Fault	Text displayed	Fault cause	Solutions
EV emergency stop	EV_E_Stop	An error has occurred, and the charging session is terminated by the vehicle forcefully	<ol style="list-style-type: none"><li>1. Pull out the charging connector, plug it back into the vehicle, and try to start the charging session again.</li><li>2. If the problem is not resolved, restart the charger and repeat Step 1.</li><li>3. If the problem persists, please contact SUNGROW customer service.</li></ol>
PWM failure	PWM_Failure	The PWM is invalid on the CP-PE interface	Please contact SUNGROW customer service.
EV reports a fault and stops	EV_Reported_Error	An error has occurred in the vehicle side, and the charging session has terminated	<ol style="list-style-type: none"><li>1. Pull out the charging connector, plug it back into the vehicle, and try to start the charging session again.</li><li>2. If the problem is not resolved, restart the charger and repeat Step 1.</li><li>3. If the problem persists, please contact SUNGROW customer service.</li></ol>
SLAC match failure	SLAC_Match_Failure	The charging session handshake - SLAC process failed	<ol style="list-style-type: none"><li>1. Pull out the charging connector, plug it back into the vehicle, and try to start the charging session again.</li><li>2. If the problem is not resolved, restart the charger and repeat Step 1.</li><li>3. If the problem persists, please contact SUNGROW customer service.</li></ol>

Fault	Text displayed	Fault cause	Solutions
SDP handshake failure	SDP_Handshake_Failure	The charging session handshake - SDP process failed	<ol style="list-style-type: none"> <li>1. Pull out the charging connector, plug it back into the vehicle, and try to start the charging session again.</li> <li>2. If the problem is not resolved, restart the charger and repeat Step 1.</li> <li>3. If the problem persists, please contact SUNGROW customer service.</li> </ol>
UDP server fault	UDPv6_Server_Fault	The charging session handshake - UDP server during SDP process is invalid	<ol style="list-style-type: none"> <li>1. Pull out the charging connector, plug it back into the vehicle, and try to start the charging session again.</li> <li>2. If the problem is not resolved, restart the charger and repeat Step 1.</li> <li>3. If the problem persists, please contact SUNGROW customer service.</li> </ol>
TCP server fault	TCPv6_Server_Fault	The charging session handshake - TCP server during charging process is invalid	<ol style="list-style-type: none"> <li>1. Pull out the charging connector, plug it back into the vehicle, and try to start the charging session again.</li> <li>2. If the problem is not resolved, restart the charger and repeat Step 1.</li> <li>3. If the problem persists, please contact SUNGROW customer service.</li> </ol>
Protocol handshake failure	Protocol_Handshake_Failure	The charging session handshake - protocol handshake (DIN/ISO15118) failed	<ol style="list-style-type: none"> <li>1. Pull out the charging connector, plug it back into the vehicle, and try to start the charging session again.</li> <li>2. If the problem is not resolved, restart the charger and repeat Step 1.</li> <li>3. If the problem persists, please contact SUNGROW customer service.</li> </ol>
Service parameter incompatibility	Service_Incompatibility	The charging session - service parameter exchange failed	<ol style="list-style-type: none"> <li>1. Pull out the charging connector, plug it back into the vehicle, and try to start the charging session again.</li> <li>2. If the problem is not resolved, restart the charger and repeat Step 1.</li> <li>3. If the problem persists, contact SUNGROW customer service.</li> </ol>

Fault	Text displayed	Fault cause	Solutions
Communication parameter incompatibility	Charge_Parameter_Incompatibility	The charging session - service parameter exchange failed	<ol style="list-style-type: none"> <li>1. Pull out the charging connector, plug it back into the vehicle, and try to start the charging session again.</li> <li>2. If the problem is not resolved, restart the charger and repeat Step 1.</li> <li>3. If the problem persists, please contact SUNGROW customer service.</li> </ol>
Cable check fault	Cable_Check_Fault	The charging session - cableCheck process failed	<ol style="list-style-type: none"> <li>1. Pull out the charging connector, plug it back into the vehicle, and try to start the charging session again.</li> <li>2. If the problem is not resolved, restart the charger and repeat Step 1.</li> <li>3. If the problem persists, please contact SUNGROW customer service.</li> </ol>
Precharge fault	Precharge_Fault	The charging session - precharge process failed	<ol style="list-style-type: none"> <li>1. Pull out the charging connector, plug it back into the vehicle, and try to start the charging session again.</li> <li>2. If the problem is not resolved, restart the charger and repeat Step 1.</li> <li>3. If the problem persists, please contact SUNGROW customer service.</li> </ol>
Current demand fault	Current_Demand_Fault	The charging session - current demand process failed	<ol style="list-style-type: none"> <li>1. Pull out the charging connector, plug it back into the vehicle, and try to start the charging session again.</li> <li>2. If the problem is not resolved, restart the charger and repeat Step 1.</li> <li>3. If the problem persists, please contact SUNGROW customer service.</li> </ol>
CP voltage abnormal	CP_Voltage_Abnormal	The CP-PE terminal voltage is abnormal	<ol style="list-style-type: none"> <li>1. Pull out the charging connector, plug it back into the vehicle, and try to start the charging session again.</li> <li>2. If the problem is not resolved, restart the charger and repeat Step 1.</li> <li>3. If the problem persists, please contact SUNGROW customer service.</li> </ol>
DC output overvolt	DC_Output	The DC output voltage exceeds	<ol style="list-style-type: none"> <li>1. Check the output voltage on the vehicle or the charger during the charging session. If the voltage is</li> </ol>

Fault	Text displayed	Fault cause	Solutions
Charging protection	Overvoltage_Protection	The DC output voltage is greater than 1020V, and the charger over-voltage protection is triggered	<p>greater than 1020V, the charging will not be successful. In this case, please contact SUNGROW customer service and do not proceed with the next steps.</p> <ol style="list-style-type: none"> <li>2. Pull out the charging connector, plug it back into the vehicle, and try to start the charging session again.</li> <li>3. If the problem is not resolved, restart the charger and repeat Step 1.</li> <li>4. If the problem persists, please contact SUNGROW customer service.</li> </ol>
DC output undervoltage protection	DC_Output_Undervoltage_Protection	The DC output voltage is lower than 195V, and the charger under-voltage protection is triggered	<ol style="list-style-type: none"> <li>1. Check the output voltage on the vehicle or the charger during the charging session. If the voltage is lower than 195V, the charging will not be successful. In this case, please contact SUNGROW customer service and do not proceed with the next steps.</li> <li>2. Pull out the charging connector, plug it back into the vehicle, and try to start the charging session again.</li> <li>3. If the problem is not resolved, restart the charger and repeat Step 1.</li> <li>4. If the problem persists, please contact SUNGROW customer service.</li> </ol>
DC output overcurrent protection	DC_Output_Overcurrent_Protection	The DC output current exceeds 82A, and the charger over-current protection is triggered	<ol style="list-style-type: none"> <li>1. Check the output current on the vehicle or the charger during the charging session. If the current is larger than 82A, the charging will not be successful. In this case, please contact SUNGROW customer service and do not proceed with the next steps.</li> <li>2. Pull out the charging connector, plug it back into the vehicle, and try to start the charging session again.</li> <li>3. If the problem is not resolved, restart the charger and repeat Step 1.</li> <li>4. If the problem persists, please contact SUNGROW customer service.</li> </ol>

Fault	Text displayed	Fault cause	Solutions
Frame communication timeout	Frame_Communication_Timeout	The communication between the charger and the vehicle is not stable, or the charger/vehicle failed to send message	<ol style="list-style-type: none"> <li>1. Pull out the charging connector, plug it back into the vehicle, and try to start the charging session again.</li> <li>2. If the problem is not resolved, restart the charger and repeat Step 1.</li> <li>3. If the problem persists, please contact SUNGROW customer service.</li> </ol>
Communication sequence fault	Communication_Sequence_Fault	The communication frame sent by the vehicle does not follow the sequence defined in the DIN SPEC 70121/ISO 15118 norm	<ol style="list-style-type: none"> <li>1. Pull out the charging connector, plug it back into the vehicle, and try to start the charging session again.</li> <li>2. If the problem is not resolved, restart the charger and repeat Step 1.</li> <li>3. If the problem persists, please contact SUNGROW customer service.</li> </ol>

## 8.2 Power Off Charger

### Prerequisite

Power off the charger to stop it from running if you need to perform routine inspections and maintenance on it.

### CAUTION

Even if the charger has stopped running, it may still be hot and cause burns. Perform operations on the device wearing safety gloves after it cools down.

Please following the instructions below to power off the charger. Otherwise, it may lead to device damage or personal injuries.

- Step 1** Switch off the AC circuit breaker between the charger and the grid.
- Step 2** Wait at least 10 minutes, until no voltage is present.
- Step 3** Open the charger's cabinet door.
- Step 4** Switch off the MCB inside the charger.
- Step 5** Switch off the MCCB inside the charger.

--End

## 8.3 Replace Power Unit

Power units inside the charger are the basic units designed for power conversion and output control. They are mainly applied to convert the AC from the grid into the DC that can be used to charge the battery.

### Prerequisite

#### **⚠ DANGER**

Only when no current or voltage is present, qualified personnel, who wear protective equipment, can perform device maintenance.

#### **⚠ CAUTION**

Temperature at the power unit surface may be very high. Be careful of burns when taking it out.



- If the power unit needs to be replaced in time due to something abnormal, contact SUNGROW for support.
- Inspect the new power unit for intactness before replacing the old one.

Steps to replace the power unit are as follows:

**Step 1** Power off the charger. See [8.2 Power Off Charger](#) for details.

**Step 2** Use the provided key to open the left cabinet door of the charger. Locate the power unit to be replaced, disconnect its AC, CAN, and DC terminals, then remove the PE wire and the screws fixing the power unit using a screwdriver.

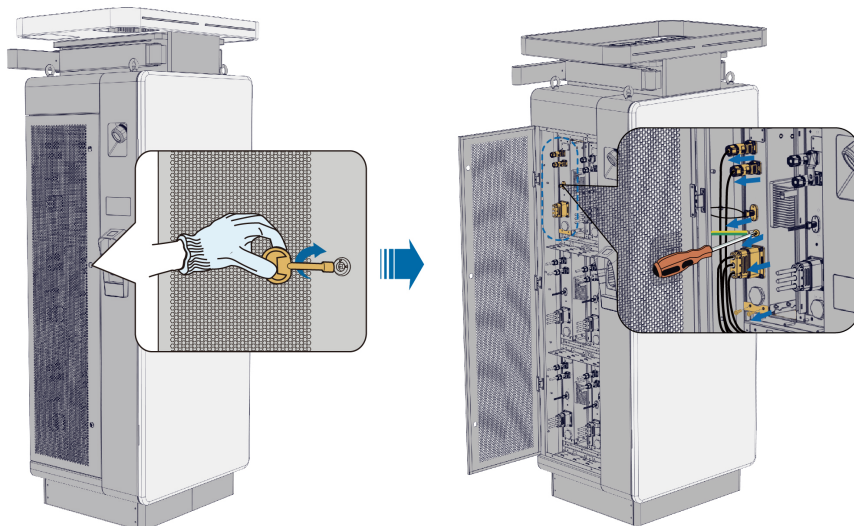

**Step 3** Use the provided key to open the right cabinet door. Remove the power unit fixing plate, then firmly grasp the upper and lower handles of the power unit and pull it out horizontally.

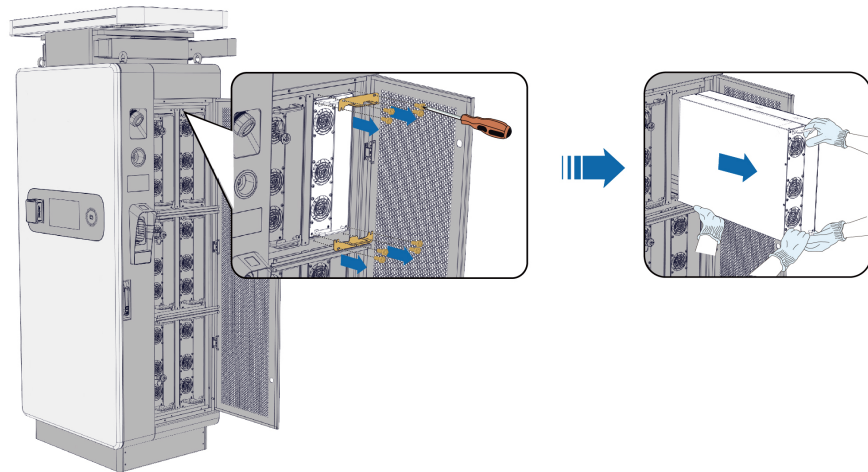

**Step 4** Slowly push the new power unit into the cabinet. Fit the gasket, screws, and wiring terminals back, by performing the above steps in the reverse order.

--End

## 8.4 Routine Dust Removal

The air inlets and outlets on both sides of the charger and the bottom rear vent cover are critical components for heat dissipation. Prolonged outdoor placement and operation may cause the accumulation of dust and debris, which can reduce cooling efficiency. To maintain optimal performance, it is recommended to clean these components every three months. In harsh environments, such as deserts, clean them more frequently.

**Step 1** Power off the charger. See [8.2 Power Off Charger](#) for details.

**Step 2** Clean the air inlets and outlets on both sides

- a. Open the air inlet and outlet doors on both sides using the key included in the accessories. Clean both sides of the doors and the intake fans with a vacuum cleaner, brush, or similar tools.

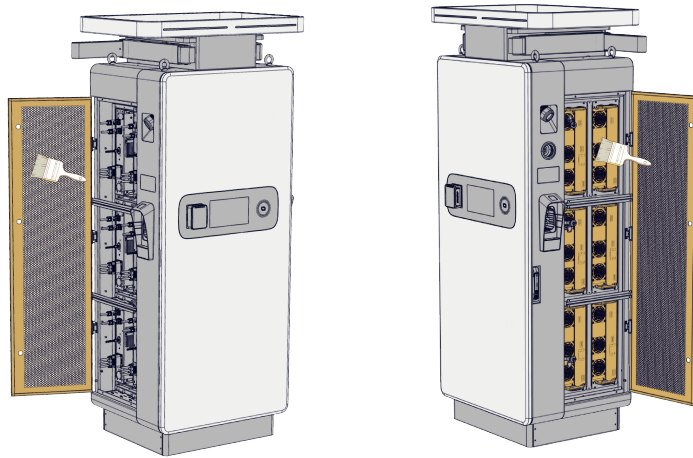

- b. Close and lock both cabinet doors promptly after cleaning.

**Step 3** Clean the bottom rear vent cover

- a. Remove the screws securing the vent cover on both sides of the charger with a screwdriver. Remove the vent cover carefully and clean both sides using a vacuum cleaner, brush, or similar tools.

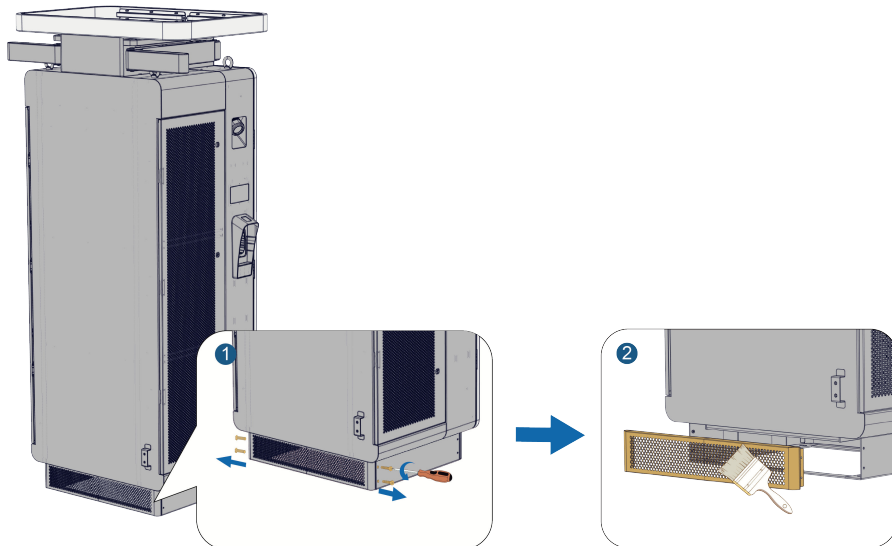

- b. Reattach the mounting plate after cleaning.

--End

# 9 Appendix

## 9.1 Technical Data

**Table 9-1 Technical Data**

Specification	IDC180E
<b>Charging Connector</b>	
Connector type	Outlet 1 : CCS2 Outlet 2 : CCS2
Number of EV served	2
Cable length	5 m (standard) 7 m (optional)
Cable management system	Yes
EVSE-vehicle protocol	DIN SPEC 70121 ISO 15118
<b>DC Output</b>	
DC output power**	Max. 180 kW x 1 or 90 kW x 2 Max. 150 kW * 1 or 60 kW + 90 kW Max. 120 kW * 1 or 60 kW * 2
DC output voltage	200 Vdc ~ 1000 Vdc
DC output current	Outlet #1: CCS2 250 A or 380 A ( optional ) Outlet #2: CCS2 250 A or 380 A ( optional )
<b>AC Input</b>	
Grid voltage	3 / N / PE, 380 Vac / 400 Vac ( ± 10 % )
Nominal grid frequency	50 Hz / 60 Hz
Earthing system	TN-C, TN-S, TN-C-S, TT
Rated input current	289 A at DC output power 180 kW 241 A at DC output power 150 kW 193 A at DC output power 120 kW
Power factor	≥ 0.99

<b>Specification</b>	<b>IDC180E</b>
Total harmonic distortion (THDi)	< 5 % at full output power
Overvoltage category	III
Standby self-consumption	≤ 48W
<b>Efficiency</b>	
Max. efficiency	96.50%
<b>Protection</b>	
Overload protection	Yes
Over/under voltage protection	Yes
Over-current protection	Yes
Short-circuit protection	Yes
Leakage current protection	Yes
Over-temperature protection	Yes
Surge protection	Yes
Emergency stop	Yes
<b>User Interface</b>	
Display	10-inch color touch screen
Language	English (standard) Other languages available by firmware upgrade
Authentication	RFID-card / Plug & Play / Auto-charge (Standard) Plug & charge / Debit or credit-card ( optional )
Firmware update	OTA ( over-the-air ) by iEnergyCharge
RFID system	ISO / IEC 14443 A / B, ISO / IEC 15693
Energy metering	MID-certified meter integrated Eichrecht / PTB-certified meter integrated ( optional )
Communication interface	WLAN / Ethernet / 4G
Communication protocol (charger-to-CSMS)	OCPP 1.6J Ready for OCPP 2.0.1

Specification	IDC180E
<b>Mechanical Data</b>	
Dimensions (W*H*D)	
Weight	≤ 500 kg <sup>***</sup>
Installation method	Floor mounted
AC cable specification	Min. 150 mm <sup>2</sup> Max. 240 mm <sup>2</sup>
<b>Environmental Data</b>	
Enclosure rating	IP65
Anti-corrosion degree	C5
Mechanical impact protection	IK10 <sup>****</sup>
Operating ambient temperature range	-35 °C - 55 °C
Allowable relative humidity range	5 % - 95 % ( non-condensing )
Max. operating altitude	≤ 2000 m
Cooling method	Smart forced air cooling
Noise (typical)	≤ 65 dB ( A ) at 1 m distance / 25 °C, at full output power
<b>Certification and standards</b>	
Certifications	CE, CB, UKCA, RCM, ADQCC, MolAT, PEA
Compliance	ETSI / EN 300 328, EN 300 330, EN 301 489-1 / 3 / 17 / 52, ETSI / EN 301 908-1 / 13, EN 50665, BS / EN IEC 61851-1, BS / EN IEC 61851-21-2, BS / IEC EN 61851-23 / 24, EN IEC 62311
Warranty	3 years (standard)

\* Payment terminal is an optional feature. Please consult Sungrow for more information.

\*\* The output power of IDC180E is configurable at power modules level.

\*\*\* The weight varies from 440 kg up to 500 kg according to the quantity of power modules.

\*\*\*\* The mechanical impact protection degree of HMI is IK08.

## 9.2 Quality Assurance

When product faults occur during the warranty period, SUNGROW will provide free service or replace the product with a new one.

### Evidence

During the warranty period, the customer shall provide the product purchase invoice and date. In addition, the trademark on the product shall be undamaged and legible. Otherwise, SUNGROW has the right to refuse to honor the quality guarantee.

### Conditions

- After replacement, unqualified products shall be processed by SUNGROW.
- The customer shall give SUNGROW a reasonable period to repair the faulty device.

### Exclusion of Liability

In the following circumstances, SUNGROW has the right to refuse to honor the quality guarantee:

- The free warranty period for the whole machine/components has expired.
- The device is damaged during transport.
- The device is incorrectly installed, refitted, or used.
- The device operates in harsh conditions beyond those described in this manual.
- The fault or damage is caused by installation, repairs, modification, or disassembly performed by a service provider or personnel not from SUNGROW.
- The fault or damage is caused by the use of non-standard or non-SUNGROW components or software.
- The installation and use range are beyond stipulations of relevant international standards.
- The damage is caused by unexpected natural factors.

For faulty products in any of above cases, if the customer requests maintenance, paid maintenance service may be provided based on the judgment of SUNGROW.



Product data such as product dimensions are subject to change without prior notice. The latest documentation from SUNGROW should take precedence in case of any deviation.

## 9.3 Contact Information

In case of questions about this product, please contact us. We need the following information to provide you the best assistance:

- Model of the device
- Serial number of the device

- Fault code/name
- Brief description of the problem

For detailed contact information, please visit: [https://en.SUNGROWpower.com/  
contactUS](https://en.SUNGROWpower.com/contactUS)

**SUNGROW**

Sungrow Power Supply Co., Ltd.

[www.sungrowpower.com](http://www.sungrowpower.com)