

User Manual

DC Charger

IDC480E-C



All Rights Reserved

All Rights Reserved

No part of this document can be reproduced in any form or by any means without the prior written permission of Sungrow Power Supply Co., Ltd (hereinafter "SUNGROW").

Trademarks

SUNGROW and other SUNGROW trademarks used in this manual are owned by SUNGROW.

All other trademarks or registered trademarks mentioned in this manual are owned by their respective owners.

Software Licenses

- It is prohibited to use data contained in firmware or software developed by SUNGROW, in part or in full, for commercial purposes by any means.
- It is prohibited to perform reverse engineering, cracking, or any other operations that compromise the original program design of the software developed by SUNGROW.

Contents

- All Rights Reserved..... I
- 1 About This Manual..... 1
- 2 Safety Instructions..... 3
 - 2.1 Safety Signs on Product..... 3
 - 2.2 Packaging, Transport, and Storage..... 4
 - 2.3 Installation Safety..... 5
 - 2.4 Electrical Safety..... 6
 - 2.5 Operation Safety..... 7
 - 2.6 Maintenance Safety..... 8
 - 2.7 Disposal Safety..... 9
- 3 Product Description..... 10
 - 3.1 Product Overview..... 10
 - 3.2 Application Scenarios..... 10
 - 3.3 Marks on the Product..... 13
 - 3.4 External Design..... 14
 - 3.5 Internal Structure..... 15
 - 3.6 Indicators..... 17
 - 3.7 Charging Cable Specifications..... 17
- 4 Mechanical Installation..... 20
 - 4.1 Installation Location Selection..... 20
 - 4.1.1 Installation Environment Requirements..... 20
 - 4.1.2 Installation Space Requirements..... 21
 - 4.1.3 Foundation Requirements..... 21
 - 4.2 Installation Preparation..... 23
 - 4.2.1 Installation Tools..... 23
 - 4.2.2 Cable Routing..... 24
 - 4.3 Packing List Inspection..... 25
 - 4.4 Charger Installation..... 27
 - 4.4.1 Foundation Drilling..... 27
 - 4.4.2 Charger Handling..... 28
 - 4.4.2.1 Handle with Crane..... 28
 - 4.4.2.2 Handle with Forklift..... 30
 - 4.4.3 Charger Mounting..... 31
- 5 Electrical Connection..... 32

5.1 Cable Requirement.....	32
5.2 Wiring Terminals Preparation.....	36
5.2.1 Crimp OT/DT/SC terminal.....	36
5.2.2 Crimp Cord-end Terminal.....	37
5.3 External ground Connection.....	37
5.4 AC Cable Connection.....	38
5.5 Charger Network Connection.....	39
5.5.1 Communication Interfaces.....	39
5.5.2 SIM Card Installation.....	41
5.5.3 Ethernet Cable Connection.....	42
5.6 Electrical Connection with Dispenser (Optional).....	43
5.6.1 DC Cable and Grounding Cable Connection.....	43
5.6.2 Power Cable Connection.....	45
5.6.3 CAN Cable Connection.....	45
5.6.4 Dispenser Network Connection.....	46
6 Commissioning.....	48
6.1 Inspection Before Commissioning.....	48
6.2 Commissioning Steps.....	49
6.3 Post-Commissioning Operations.....	52
7 LCD Touch Screen.....	54
7.1 Charging Procedure.....	54
7.1.1 Select an Authentication Method.....	55
7.1.2 Select a Charging Connector.....	58
7.1.3 Plug Connector for Charging.....	59
7.1.4 View Charging Information.....	60
7.1.5 Stop Charging.....	61
7.2 Other Functions.....	61
7.2.1 Dual Charging.....	61
7.2.2 Change System Language.....	62
7.2.3 Emergency Stop.....	63
7.2.4 Device Fault Diagnosis.....	64
7.2.5 Network Connection Diagnosis.....	65
8 iEnergyCharge App.....	66
8.1 Install iEnergyCharge App.....	66
8.2 Create an Account.....	66
8.3 Log in to an Account.....	69
8.4 Device Operation and Maintenance.....	70
9 Maintenance.....	71
9.1 Inspection Instructions.....	71

9.2 Power off the Charger.....	71
9.3 Routine Inspection.....	73
9.4 Troubleshooting.....	74
10 Appendix.....	78
10.1 Technical Data.....	78
10.2 Quality Assurance.....	80
10.3 Contact Information.....	81

1 About This Manual

Declaration

To ensure the safe use of the product, please read through the below information carefully:

1. The warranty period agreed for this product is subject to the contract.
2. This manual is intended for personnel who are responsible for product installation and other work on the product. Users must have certain electrical and mechanical expertise, and be familiar with the electrical and mechanical schematics and the characteristics of electronic components. SUNGROW shall not be held liable for any personal injury or financial loss arising from the installation operation carried out by non-qualified personnel or not in compliance with the safety instructions specified in this manual.
3. The content of this manual, including the pictures, marks, and symbols used herein, is all owned by SUNGROW. No part of this manual may be reproduced by any non-internal staff without the prior written authorization of SUNGROW.
4. The manual may be updated and revised from time to time, however, there still might be slight deviations from the real product or errors. In such cases, the actual product you have purchased should take precedence. You can find the latest version of the user manual on the company website, or reach your sales for it.
5. To ensure the safety of the installation personnel, the product, and the system, follow strictly the safety instructions specified in this manual when installing the product. SUNGROW shall not be held liable for any personal injury or financial loss arising from failure to follow the instructions specified in this manual.
6. If maintenance on or alteration to this product is needed, please contact SUNGROW customer service in advance. The copyright of this user manual belongs to SUNGROW, and any rights not expressly granted are reserved. The content of the manual is subject to change without notice and the actual up-to-date product shall prevail.

Valid for

Product Model	Product Aliases
IDC480E-C	Charger, "the device/product"

Target Group

This manual is intended for qualified technical persons who are responsible for the installation, operation, and maintenance of the product, as well as people who use the product for charging. Installation must only be performed by qualified technical persons, and qualified technical persons must be:

- Have certain electrical wiring, electronic, and mechanical expertise, and be familiar with electrical and mechanical schematics;

- Have received professional training in the installation and commissioning of electrical equipment;
- Be able to respond quickly and effectively to dangers or emergencies that may occur during the process of installation and commissioning;
- Be familiar with applicable local standards and specifications of the country/region where the project is located;
- Read through this manual carefully and have a good understanding of the relevant safety instructions.

How to Use This Manual

Read through this manual carefully before using the product, and keep it properly in an easy-to-reach place. The manual may be updated and revised from time to time, however, there still might be slight deviations from the real product or errors. In such cases, the actual product you have purchased should take precedence. You can also download the latest version of the user manual at support.sungrowpower.com.

Symbols in the Manual

To ensure the safe and efficient use of the product, the manual provides relevant safety information, which are highlighted using relevant symbols. Symbols that may appear in this manual are listed below, but not all. Please read carefully for better use of this manual.

DANGER

Indicates an imminently hazardous situation which, if not avoided, will result in death or serious injury.

WARNING

Indicates a moderately hazardous situation which, if not avoided, will result in death or serious injury.

CAUTION

Indicates a slightly hazardous situation which, if not avoided, may result in minor or moderate injury.

NOTICE

Indicates a potential hazard which, if not avoided, will result in device malfunction or property damage.



Indicates supplementary information, emphasis on specific points, or tips related to the use of the product that might help to solve your problems or save your time.

2 Safety Instructions

Follow strictly the relevant safety instructions during the process of product installation, commissioning, operation, and maintenance. Improper use or misoperation may result in:

- Injury to or death of the operator or other people.
- Damage to the product, or to the property that belongs to the operator or a third party.

Strictly follow the safety instructions stated in the manual to avoid the hazards mentioned above.



- Safety instructions in this manual should only serve as a supplement and not all-encompassing regarding all the norms that need to be followed. All work should be carried out considering the actual situation on the site.
- SUNGROW shall not be held liable for any damage caused by violation of general safe operation requirements, safety standards, and the safety instructions specified in this manual.
- Product installation, operation, and maintenance should be conducted in compliance with applicable local laws, regulations, and specifications. Safety instructions in this manual should only be a supplement to the local laws, regulations, and specifications.

2.1 Safety Signs on Product

To ensure users' personal and property safety, warning signs are provided on the product, which should be observed at all times.

Table 2-1 Safety Signs on the Product

Symbols	Description
	Burn hazard due to the hot surface that may exceed 60°C.
	Disconnect the device from all the external power sources before maintenance.
	Danger to life due to high voltages! Only qualified personnel can open and maintain the device.

2.2 Packaging, Transport, and Storage

Packaging

- The product is packed in a cardboard box with orientation markings that provide loading and unloading instructions.
- Use brushed film to wrap the product tightly, put foam guards around it for protection, and then put it in the cardboard box.

Transport

- All work related to transport must be carried out in compliance with the applicable local laws and regulations of the country/region.
- Do not turn the product upside down during transport.
- Measures should be taken to fasten the goods during transport, so as to avoid damages to product packaging due to strong shaking or bumping.
- Carry out an inspection upon receiving the delivery. In case of any damage to the goods during transport, contact your transport service provider and SUNGROW for negotiation.

Storage

- The packaged product should be stored indoors in places with a relative humidity of 5% to 95% and ambient temperature of -35°C to 55°C.
- When the ambient temperature is above 45°C, it's recommended to add shading for extra protection.
- The place where the product is stored should be kept dry, clean, and well-ventilated, protected from hazardous gases.
- Do not store the product in a place where corrosives are kept.

Unpacking and Inspection

NOTICE

Non-qualified personnel are forbidden from disassembling the product or moving its components.

- Non-qualified personnel are forbidden from disassembling the product or moving its components.
- Check if the product you have received matches the order you placed.
- Check if the items packed in the box matches the packing list.
- Inspect the product for external damages or damages to its structural parts.
- Check if the safety signs, warning labels, and the nameplate on the product are all legible.
- In case of any problem with the above-mentioned inspection items, do not proceed with installation and contact SUNGROW in time.

2.3 Installation Safety

Improper installation operation may result in personal injuries, while poor operating environments may affect the charging efficiency. Therefore, installation personnel must read through the instructions specified in this section carefully before installing the product.

Installation Notice

- All work related to installation must be conducted in compliance with the applicable local laws and regulations of the country/region.
- Proceed with the subsequent work only if the qualified personnel designated by SUNGROW confirm that the environment where the product is to be installed meets the requirements after an assessment.
- Perform installation only if the product is intact without any signs of damage.
- Installation must be performed by qualified personnel who wear proper personal protective equipment.
- Ensure all electrical connections of the product have been disconnected before installation.
- Before installation, inspect the products and tools to be used and ensure they have all undergone regular maintenance.
- Where hole drilling is required during installation, avoid the internal water pipes and electrical wires when drilling.
- Install the product in a well-ventilated place.
- Do not install the product in an environment with flammables, explosives, or smoke.
- Stop the installation in the event of severe weather such heavy rain, heavy fog, or strong wind.

Handling Notice

- Installation personnel should wear protective equipment such as anti-impact shoes and safety gloves when handling the product to ensure their own safety.
- When handling the product, get prepared for carrying its weight and keep the balance to prevent it from tilting or falling.
- Do not let go of the product during handling, unless it has been fastened securely.
- The sealed wood crate or tray, upon its arrival on the site, must be loaded/unloaded and handled with a crane or forklift that has sufficient load capacity and is operated by qualified personnel.

Notice for Handling with a Crane

- Use only specialized cranes that are operated by qualified personnel.
- The load capacity of the crane should meet the requirements of the product's specification.
- The slings must all have a tensile strength and length that meet the requirements.
- The lifting rings on the top of the product are firmly attached.
- No one is allowed to stay under the product when it is lifted up.

- When rotating the crane for unloading, keep it rotating at a low speed. Keep the product steady and as close to the ground as possible.
- Do not shake the slings during handling.
- Do not keep the product lifted up for a long period of time.
- Do not drag the product along any surface.

Notice for Handling with a Forklift

- Use only specialized forklifts that are operated by qualified personnel.
- The carrying capacity of the forklift should meet the requirements of the product's specification.
- Make sure there are no obstacles, slopes, or other unevenness along the moving path of the product.

2.4 Electrical Safety

Improper wiring may result in personal injuries. Hence, installation personnel must read through the wiring instructions carefully before proceeding with this work.

Wiring Notice

DANGER

- Electrical connection must be performed by qualified personnel who wear personal protective equipment.
 - Be sure to use specialized insulated tools when performing electrical connection.
-
- All work related to wiring must be conducted in compliance with the applicable local laws and regulations of the country/region.
 - Wiring must be done in compliance with the applicable local grid regulations and relevant safety instructions specified for the product.
 - The specification of cables used should meet the relevant requirements. The cables should be properly insulated and firmly connected.
 - Observe the warning signs on the product, and perform operations by strictly following the corresponding safety instructions.
 - Before electrical connection, make sure the product is not damaged. Otherwise, it may cause danger.
 - Before electrical connection, make sure the product's switches and all switches connected to it are turned "OFF"; otherwise, it may lead to electric shocks.
 - Before electrical connection, be sure to test with a measuring instrument and confirm the cables are voltage-free.
 - Improper wiring may cause damage to the product and such damages will not be covered by warranty.

2.5 Operation Safety

There is high voltage inside the product when it is running, and improper operation may cause personal injuries or property damages. Please perform operations by strictly following the safety instructions specified in this manual and other relevant documents when charging EVs.

Operation Notice

DANGER

- Do not touch any live part of the product when it is running; otherwise, it may lead to electrical shocks.
 - Do not touch any wiring terminal on the product when it is running; otherwise, it may lead to electrical shocks.
 - Do not remove any part or component from the product when it is running; otherwise, it may lead to electrical shocks.
-
- Operations must all be performed in compliance with the applicable local laws and regulations of the country/region.
 - Do not use an extension cable when connecting the EV to the dispenser.
 - Do not bend, squeeze, or crush the charging connector, which may result in mechanical damage.
 - Only EVs can be connected to the charging dispenser. Do not connect any other devices for charging (e.g., electric tools).
 - Make sure the charging connector does not come into contact with heat, dirt, or water.
 - Please handle the charging connector gently. Plug or unplug the connector neatly at one go, and do not shake it.
 - Start charging only when the car sits perfectly still. Do not start the car in the middle of a charging process.
 - If the product is not covered by a rainproof shield, please charge with caution in the event of a thunderstorm.
 - Do not use the dispenser when its charging connector or cable is defective, frayed, cracked, or in case of exposed wires. Contact SUNGROW if you have found any of the above issues.
 - Do not plug or unplug any connector of the dispenser during the charging process.
 - During the charging process, do not let children go near or use the dispenser, so as to prevent them from getting hurt.
 - During the charging process, do not touch any hot part of the product (e.g., air outlet for heat dissipation); otherwise, it may cause burns.
 - After charging, insert the charging connector back into the holder on the dispenser, so as to avoid the ingress of water or sand into the connector. Also, put away the cable in time and keep it in a place out of the vehicle's reach so that it will not get run over.
 - In case of anything abnormal during use, press the emergency stop button immediately and cut off the power supply.

2.6 Maintenance Safety

There is high voltage inside the product when it is running, and improper maintenance operation may cause personal injuries or property damages. Therefore, it is necessary to power off the product before maintenance and perform operations by strictly following the safety instructions specified in this manual and other relevant documents.

Maintenance Notice

DANGER

- Only when no current or voltage is present, qualified personnel, who wear protective equipment, can perform maintenance.
 - Do not touch the pins inside the charging connector when it is powered on.
-
- All work related to maintenance must be done in compliance with the applicable local laws and regulations of the country/region.
 - Perform maintenance only when you have a good understanding of this manual and appropriate tools and testing instruments.
 - It is required to inspect the charging connector for damages on a regular basis and check if its enclosure is in a good state and supporting facilities are all in readiness.
 - Keep the charging connector clean and dry. Wipe it off using a clean dry cloth in case of any dirt.
 - Wait at least 10 minutes after the product stops running. Proceed with maintenance after confirming the voltage has lowered to a safe level.
 - Even if the product has stopped running, it may still be hot and cause burns. Perform operations on the product wearing protective gloves after it cools down.
 - Before maintenance, be sure to check the warning labels inside the product and follow the corresponding instructions.
 - Before maintenance, make sure the product, the external devices connected to it, and the electrical connections are in a safe state.
 - During the maintenance process, prevent irrelevant personnel from entering the site, whenever possible. Set up temporary warning signs or fence off an area to keep irrelevant personnel away and avoid accidents.
 - Maintenance should be performed by following the electrostatic protection rules.
 - Stop maintenance in the event of extreme weather.
 - Only after faults that may affect its safety performance are all removed, the product can be powered on again.
 - For the product that has a long downtime, a thorough and detailed inspection must be carried out before powering it on again. Only after it is inspected and tested by qualified personnel, it can be powered and put into operation again.
 - To minimize the risk of electric shocks, do not perform maintenance operations that are not specified in this manual. If needed, please contact SUNGROW for maintenance and repair services. Otherwise, damages caused therefrom will not be covered by the warranty.

2.7 Disposal Safety

Please dispose of the decommissioned product strictly in accordance with applicable local regulations and standards to avoid property damages or personal injuries.

Disposal Notice

- All work related to product disposal must be done in compliance with the applicable local laws and regulations of the country/region.
- Ensure the safety signs, warning labels, and the nameplate on the product are all legible before disposal.

3 Product Description



The image shown here is for reference only. The actual product received may differ. Changes may be made without prior notice.

3.1 Product Overview

The IDC480E-C charger is mainly used in public charging pools for quick EV charging. With a rated power of 480 kW, it allows up to 4 charging connectors to be used for charging at the same time.

Earthing Systems

The device can be used in grids adopting TN-S, TN-C-S, TT and TN-C earthing systems.

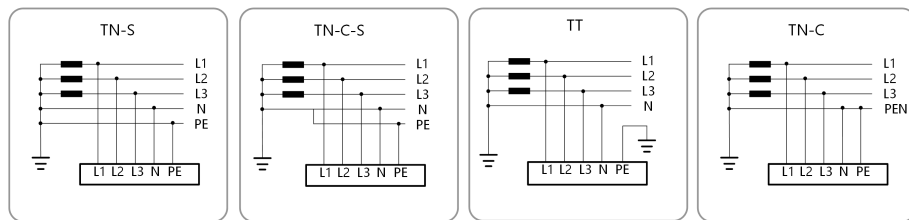
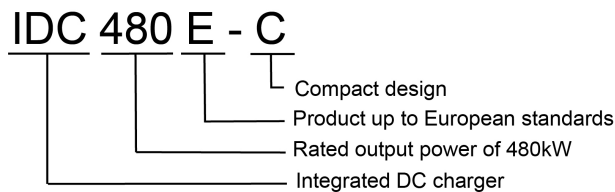

Figure 3-1 Earthing Systems

Product Model

The device model is IDC480E-C, as demonstrated below.



3.2 Application Scenarios

The IDC480E-C charger has a rated power of 480 kW and consists of 12 charging power units, each with a capacity of 40 kW. It is equipped with power conversion and distribution capacities, allowing allocation in minimum 40kW increments.

The IDC480E-C charger is mainly used in public charging stations for quick EV charging and dispenser power supply. Users can connect the product to a dispenser as needed.

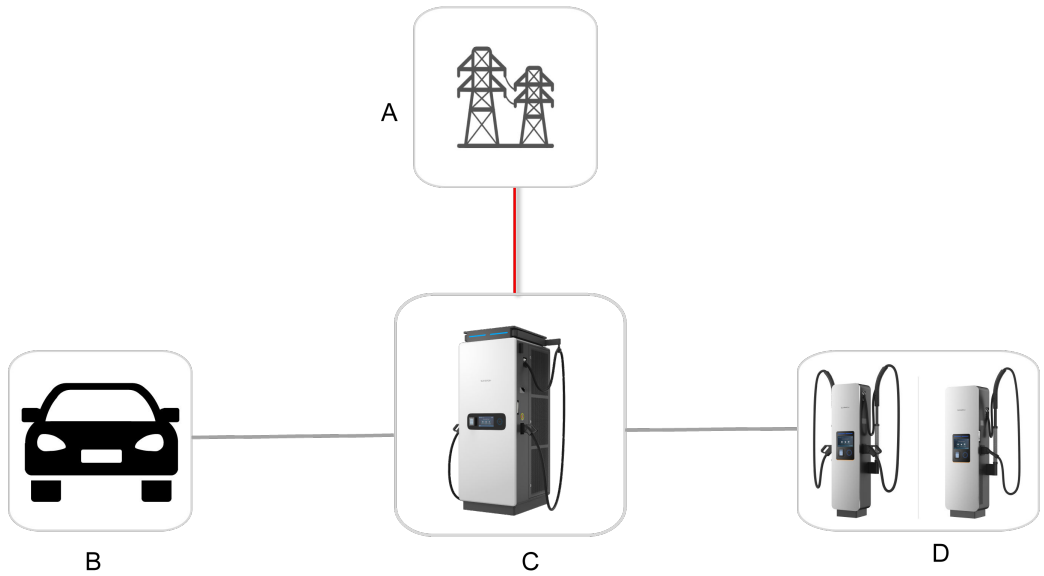

Figure 3-2 Application Scenario Diagram

No.	Item	Description
A	Grid	The use of IDC480E-C is supported in grids adopting TN-S, TN-C-S, TT and TN-C earthing systems.
B	Electric vehicle (EV)	EV to be charged. It has a power battery inside.
C	Charger	IDC480E-C
D	Dispenser (optional)	Air-cooled/liquid-cooled dispenser, connected with IDC480E-C for power to charge EV.

For ease of charger operation and management, two charging scenarios are provided for users to choose:

- Near-end charging: Operate the charger using an RFID card, a credit card, or its LCD display.
- Remote charging: Operate the charger through the third-party operation platform.

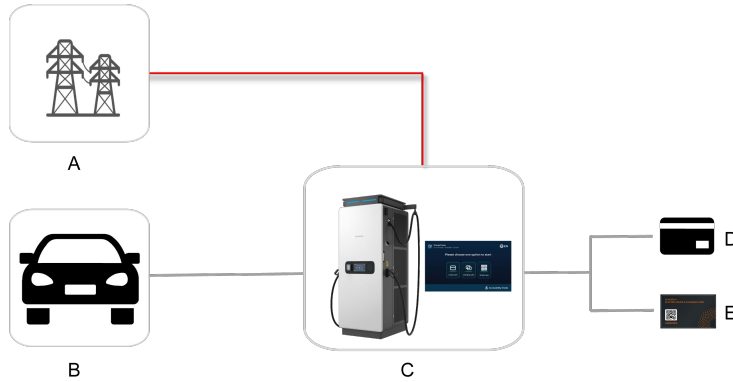

Figure 3-3 Near-end Charging

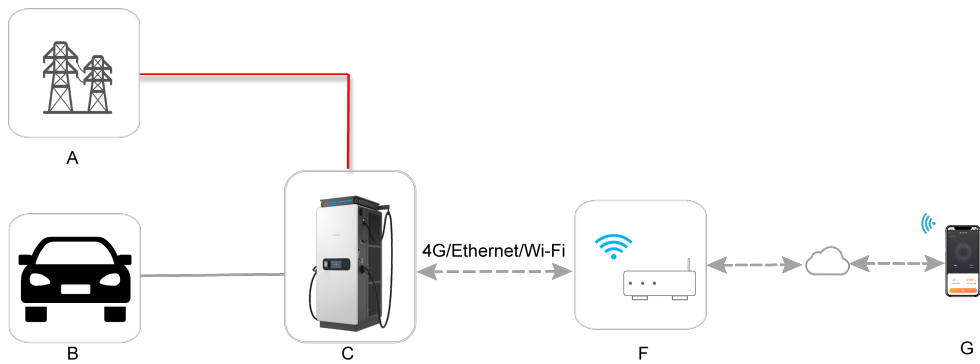









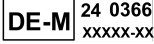



Figure 3-4 Remote Charging

No.	Item	Description
A	Grid	The use of IDC480E-C is supported in grids adopting TN-S, TN-C-S, TT and TN-C earthing systems.
B	EV	EV to be charged. It has a power battery inside.
C	Charger	IDC480E-C
D	Credit card	Users can start charging using IDC480E-C with a credit card.
E	RFID card	Users can start charging using IDC480E-C with an RFID card.
F	Communication base station/router	Provides stable 4G/Ethernet/Wi-Fi networks for the charger.
G	Third-party operation platform	Charger operation and management platform for users.

3.3 Marks on the Product

Marks	Description
	Additional grounding point.
	Disconnect the device from all external power sources before maintenance.
	Danger to life due to high voltages! Only qualified personnel can open and maintain the device.
	Do not touch live parts until 10 minutes after disconnection from the sources!
	CE mark of conformity. EU/EEA Importer.
	Do not dispose of the device together with household waste.
	Read the user manual before maintenance.
	Burn hazard due to the hot surface that may exceed 60°C.
	TÜV mark of conformity.
	PTB mark of conformity.
	Regulatory compliance mark.

3.4 External Design

Dimensions

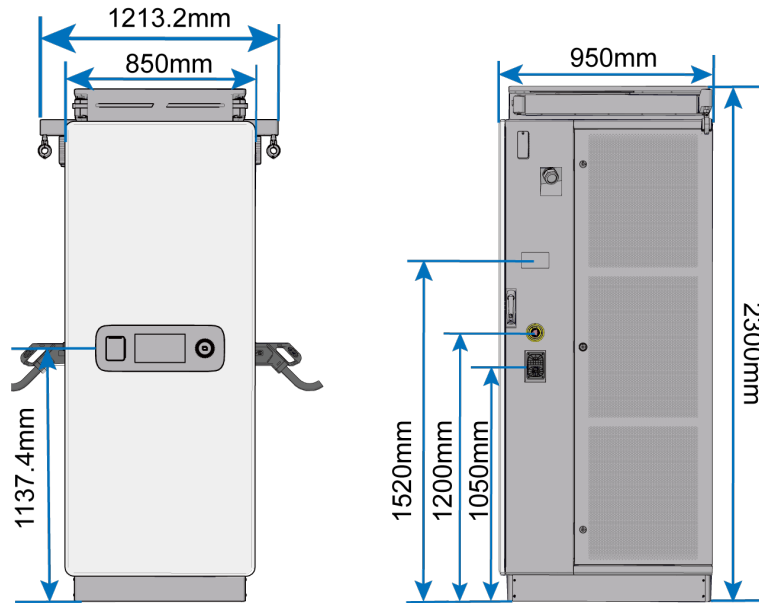

*The dimensions of the real product may differ.

External Design

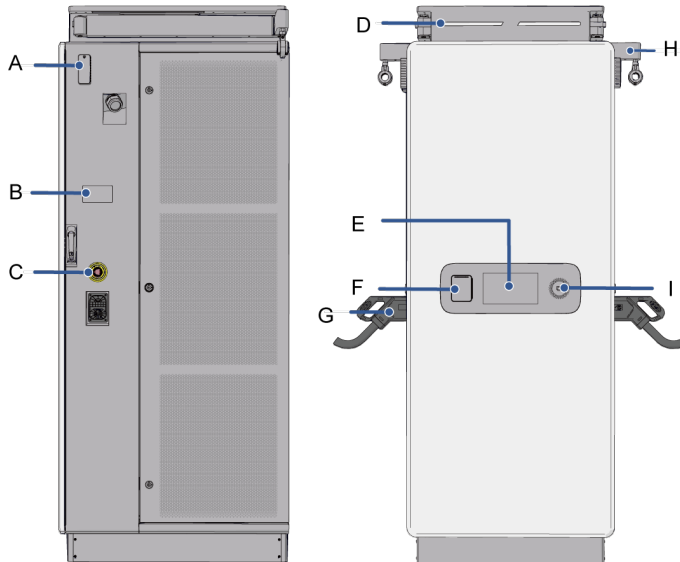

(A) Antenna

(B) Meter

(C) Emergency stop button

(D) LED Indicator

(E) Display screen

(F) Credit card reader

(G) Charging connector

(H) Cable management system

(I) Energy-Star Ring (card reader)

3.5 Internal Structure

Internal Structure (Front Door)

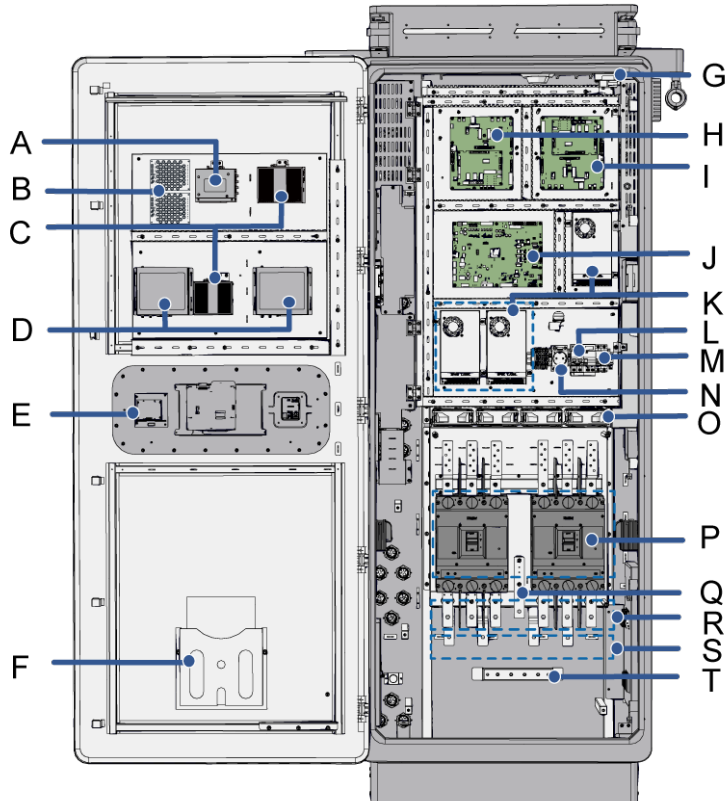

(A) Router

(B) Capacitor board (Optional)

(C) Switch

(D) Toll control unit (TCU)

(E) LCD screen assembly

(F) Document pocket

(G) Access control switch

(H) CCU1 (charging connector A Charging Control Unit)

(I) CCU2 (charging connector B Charging Control Unit)

(J) Power control unit (PCU)

(K) Power supply unit (PSU)

(L) Residual Current Circuit Breaker (RCCB)

(M) Miniature circuit breaker (MCB)

(N) Maintenance socket

(O) Axial flow fan

(P) Molded case circuit breaker (MCCB)

(Q) Neutral copper bar

(R) AC input copper bar

(S) DC output copper bar

(T) PE grounding copper bar

Internal Structure (Right and Left Side)

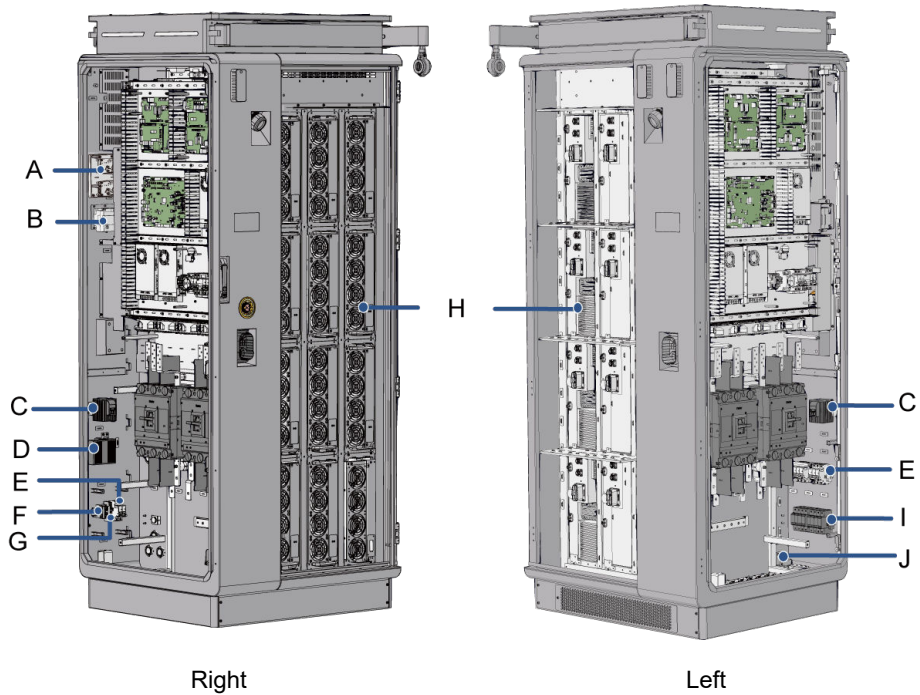

(A) Insulation tester

(B) Meter

(C) Heater

(D) Switch

(E) Miniature circuit breaker (MCB)

(F) CAN wiring terminal

(G) Power supply wiring terminal

(H) Power units

(I) Surge Protective Device (SPD)

(J) Flood sensors

3.6 Indicators

IDC480E-C is equipped with two types of indicators, the top LED indicators, and the Energy Star-Ring on the front. The left and right top indicators indicate the status of the left and right charging connectors separately, and the Energy Star-Ring indicates the overall status of the charger.

Table 3-1 Indicator Description

Indicator	Indicator Status	Charger Status	Remark
LED Indicators	Steady green	The charging connector is in the standby state	Normal. Indicators for the left and right connector are independent of each other.
	Breathing blue	The charging connector is being used for charging	Normal. Indicators for the left and right connector are independent of each other.
	Steady blue	Fully charged	Normal. Indicators for the left and right connector are independent of each other.
	Steady red	Fault	Abnormal. Indicators for the left and right connector are independent of each other.
Energy Star-Ring	Steady blue	Charger works normally.	Normal.
	Blink blue	Authentication successful, charging initiated.	Normal.
	Steady red	Fault with the charger.	Abnormal. In case of a fault with only one of the charging connectors, the indicator is still steady blue.

3.7 Charging Cable Specifications

Cable Working Radius

The standard charging cables included in the cable management system are 5 meters or 7 meters in length. The actual working radius of the cables is 3.3 meters and 5 meters respectively, as shown in the figures below:

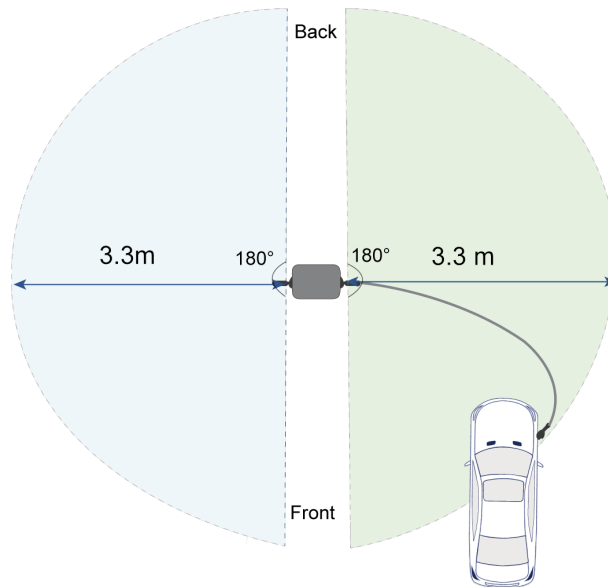

Figure 3-5 Actual working radius of the 5-meter cable

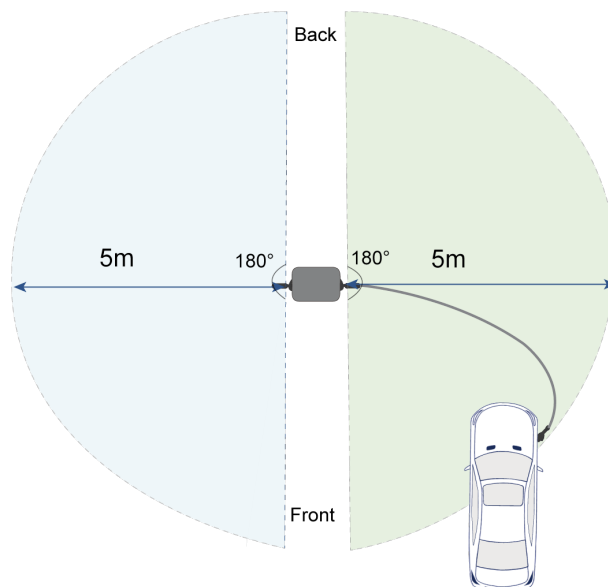
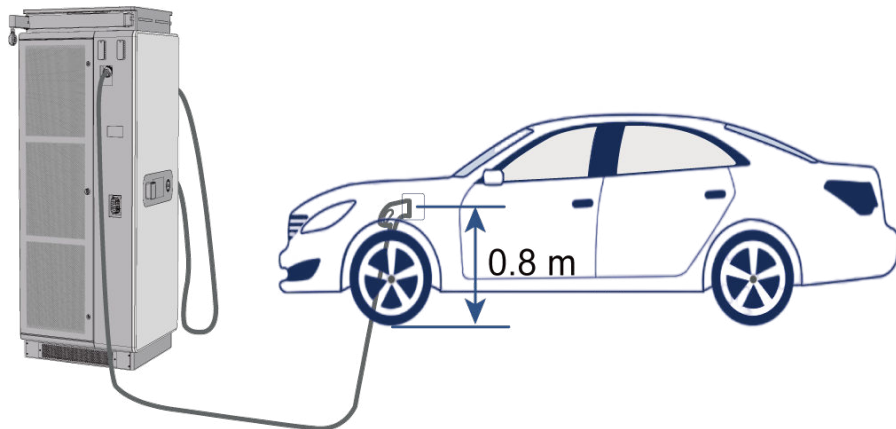

Figure 3-6 Actual working radius of the 7-meter cable



Ensure that there are no sharp objects within the working radius of the cable to prevent damage to its insulation and ensure proper functioning.

The 3.3-meter and 5-meter working radii are based on the scenario where the EV's charging port is 0.8 meters above the ground.



The cable management system can effectively prevent damage caused by the cable dragging on the ground.

4 Mechanical Installation

WARNING

Respect all local standards and requirements during mechanical installation.

4.1 Installation Location Selection

4.1.1 Installation Environment Requirements

The device should be installed in an environment that meets the following requirements:

- The place where the device is installed must be free from flammables and explosives.
- Do not install the device in a place with corrosives such as corrosive gas and organic solvent, etc.
- The place where the device is installed and operates should be free from strong vibration, strong impact, and strong electromagnetic field interference. The external magnetic field strength should not exceed 0.5 mT.
- The place where the device is installed must be free from mediums carrying explosion hazards, without hazardous gas or conductive mediums, which may corrode the metal or damage the insulation, around it.
- Please consult SUNGROW before installing the device outdoors in areas prone to salt damage, which mainly are coastal areas within 500 meters of the coast. The sedimentation amount of salt spray is correlated to the characteristics of the seawater, sea winds, precipitation, air humidity, topography, and forest coverage in the adjacent sea areas, and there are substantial differences between different coastal areas.
- Please install the device in a place with proper temperature and humidity. The allowable temperature and humidity range are shown in the figure below:

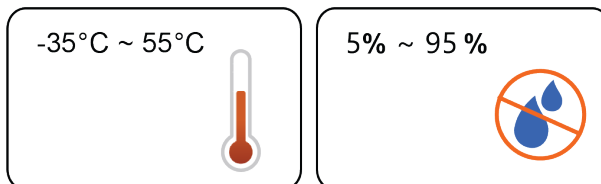

- Do not install the device in dusty and smoky environments.
- It is suggested to install the device in a place with shelter, so as to prevent it from getting impacted by direct sunlight or severe weather (e.g., snow, rain, and lightning). The device will derate in high temperatures for self-protection. If installed in a place directly exposed to sunlight, as the temperature rises, the device may witness power reduction.
- Install the device in a well-ventilated place to ensure good heat dissipation.

- This device is not intended for use in residential environments and may not provide adequate protection to radio reception in such environments.
- The device must be installed at least 30 meters away from any third-party wireless communication facilities.
- It is recommended that the product be installed outside a 50-meter range from residential areas. When geographical conditions do not allow for a 50-meter range, noise reduction measures can be taken. For specific plans, please consult the station designers.

4.1.2 Installation Space Requirements

To ensure good heat dissipation and easy maintenance, the minimum space between the device and the objects around it should not be smaller than that specified by the requirements.

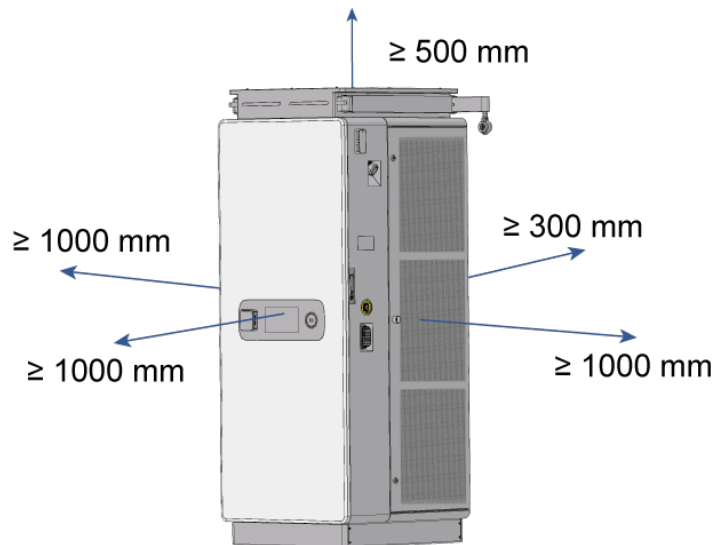

Figure 4-1 Space Requirements for Installation

To protect the device from direct sunlight, rain, and snow and extend its service life, it is recommended to set a rainproof shed for the device.

4.1.3 Foundation Requirements

Considering its heavy weight, please install the device on a solid brick or concrete foundation to ensure its stable operation. The requirements for foundation building are as follows:

- The soil on the installation site should have a certain degree of density. It is recommended that the relative density of soil on the installation site be at least 98%. In case the soil on the site is loose, take relevant measures to make sure the foundation is stable.
- The bottom of the foundation pit must be compacted, filled and made even, so that it can provide sufficient and effective support for the device.

- The foundation should be higher than the horizontal ground to protect the device base and interior against rain erosion.
- The cross-sectional area and height of the foundation should meet the requirements.
- Cable laying should be taken into consideration when building the foundation.
- Pre-bury the cable conduit at the foundation bottom, according to the location of the cable inlet provided on the device.
- A drainage system is required, so as to prevent the bottom or internal components of the device from being soaked during the rainy season or a heavy rainfall.

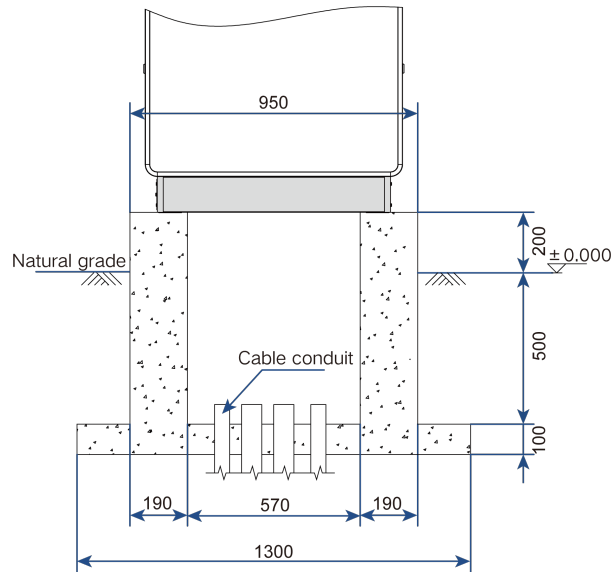

Figure 4-2 Foundation Dimensions (mm)

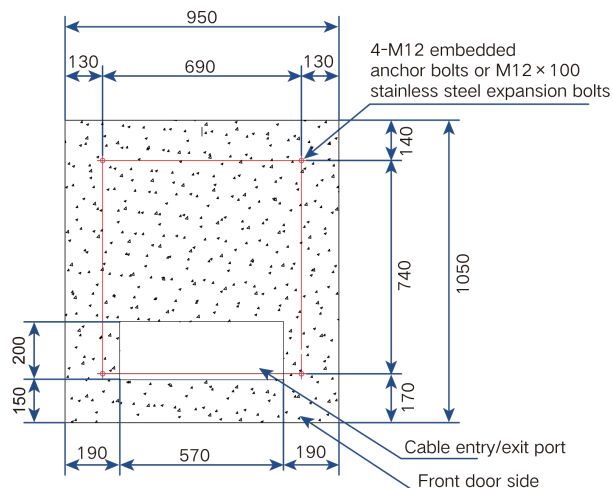

Figure 4-3 Location of Expansion Bolt Holes



The foundation dimensions shown in the illustration are for reference only. Users must determine the foundation size based on site conditions while ensuring compliance with local regulations and safety standards.

4.2 Installation Preparation

4.2.1 Installation Tools

Installation tools to be used include but are not limited to those listed below. If necessary, use other auxiliary tools at the site.

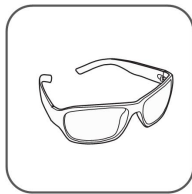

Goggles



Safety gloves



Safety shoes

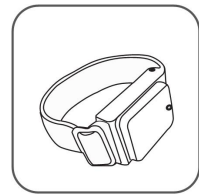

Anti-static wrist strap



Phillips screwdriver

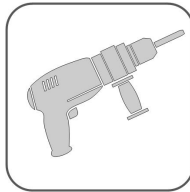

Hammer drill
($\phi 16$)

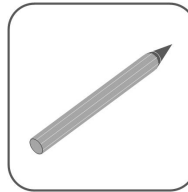

Marker



Safety helmet

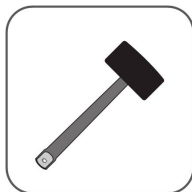

Rubber mallet



Socket wrench set
(M6, M10, M12)

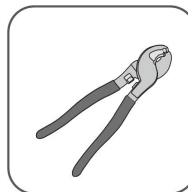

Wire cutter

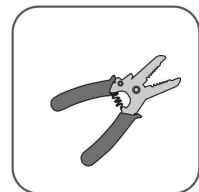

Wire strippers

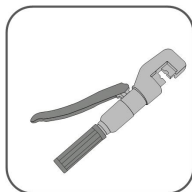

Hydraulic plier

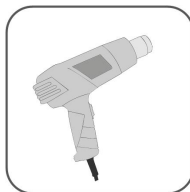

Heat gun

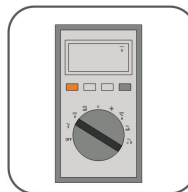

Multimeter



Vacuum cleaner



Pan head tamper
proof wrench set

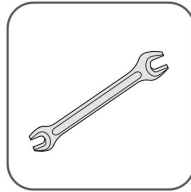

No.13 wrench
No.19 wrench

Figure 4-4 Installation Tools

4.2.2 Cable Routing

Step 1 Route the cables along the pre-embedded conduits, with one end placed at the cable inlet/outlet holes on the charger foundation, and the other end placed at the inlet/outlet holes on the foundation of the upstream distribution cabinet or the dispenser.



- For the location and dimensions of the cable inlet/outlet holes on the charger foundation, refer to [4.1.3 Foundation Requirements](#)
- To avoid wiring errors that may cause device malfunction, it is recommended to clearly label both ends of each cable (e.g., using adhesive labels) before cable routing, and to double-check all connections before and after wiring.

Step 2 Leave appropriate cable lengths based on the height of the terminal connection points.

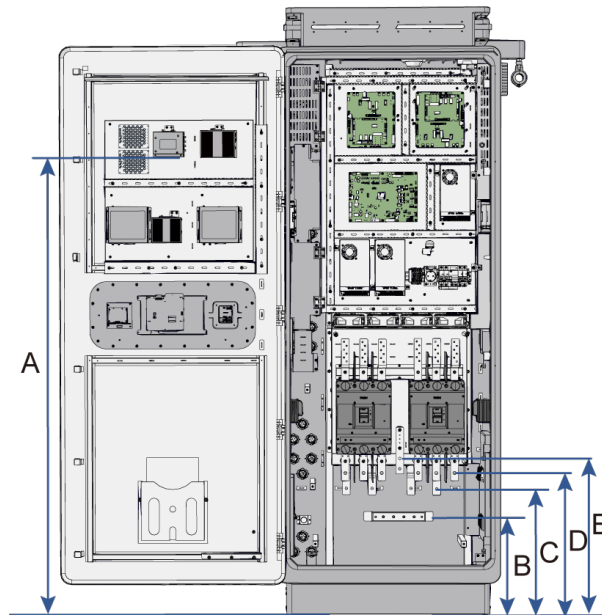

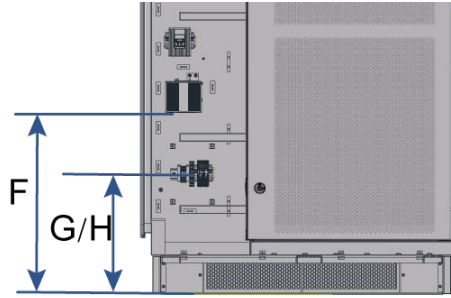

Table 4-1 Connection Point Heights Inside the Charger

No.	Connection Point	Height Inside Charger (mm)
A	Ethernet port (charger network)	1723.1
B	PE grounding copper bar	342.5
C	DC output copper bar	458.5
D	AC input copper bar	525.5
E	Neutral copper bar	580.5
F	Ethernet port (dispenser network)	555.3
G	CAN wiring terminal	350
H	Power supply wiring terminal	350

--End

4.3 Packing List Inspection

The device has undergone thorough tests and strict inspections before delivery. However, as it may still get damaged during transport, please carry out an inspection carefully before installation.

- Inspect the packaging for any damages.
- Unpack and inspect the items inside for any damages.
- Be careful not to damage the device while using tools for unpacking.

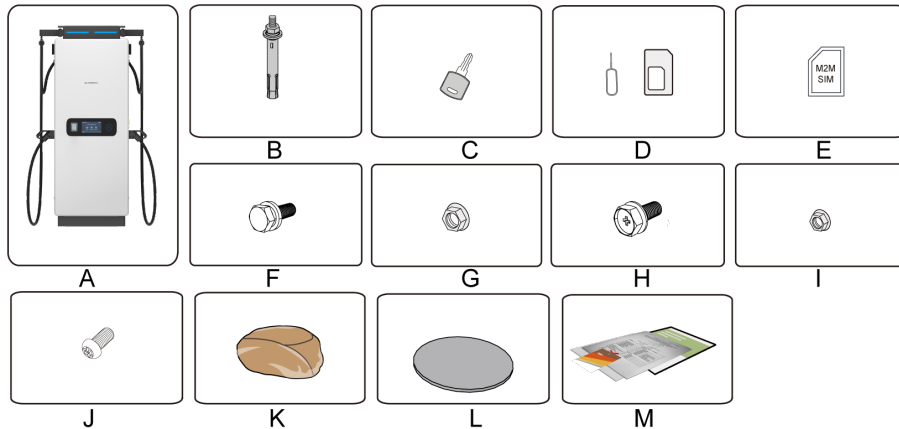

No.	Name	Quantity	Description
A	IDC480E-C Charger	1	DC charger
B	M12×100 expansion bolt	4	Used to secure the charger onto the foundation
C	Door key	2	Used to open the charger door
D	SIM card ejector pin and holder	2	Used to install the SIM card
E*	M2M_2FF 4G IoT SIM card (optional)	1	Used to connect the charger to the network
F	M10×30 bolt assembly	10	Used to secure DC cables and AC phase wires
G	M10 hex flange nut	10	Used with M10×25 bolts, to secure DC cables and AC phase wires
H	M8×20 bolt assembly	8	Used to secure PE wire and N wire
I	M8 hex flange nut	2	Used with M8×20 bolts, to secure PE wire and N wire
J	M5×12 screw	8	Used to secure the cover plate at the bottom of the charger

No.	Name	Quantity	Description
K	Fireproof mud	1	Used to seal off the cable inlet/outlet holes at the bottom of the charger
L	Emergency stop protective cover	1	Used to protect the emergency stop button
M	Documents	-	Quick Installation Guide, certificate of conformity, warranty card, packing list, etc

In case of any damages or missing items, do not install the device. Contact your transport service provider or SUNGROW, and provide relevant photos to ensure effective assistance.

4.4 Charger Installation

4.4.1 Foundation Drilling

- Step 1** Build a foundation according to [4.1.3 Foundation Requirements](#).
- Step 2** Mark the holes for drilling on the foundation by referring to the figure of [Figure 4-3 Location of Expansion Bolt Holes](#).
- Step 3** Use a hammer drill to drill holes at the designated positions. The hole diameter is $\varnothing 16$ and the depth is 100mm.
- Step 4** Put the sleeves and screws of the expansion bolt assembly in the holes. Then, tap them using a rubber mallet until the expansion sleeves are fully seated in the holes.
- Step 5** Unscrew the bolts, remove the flat and spring washers, and store them properly for later use.

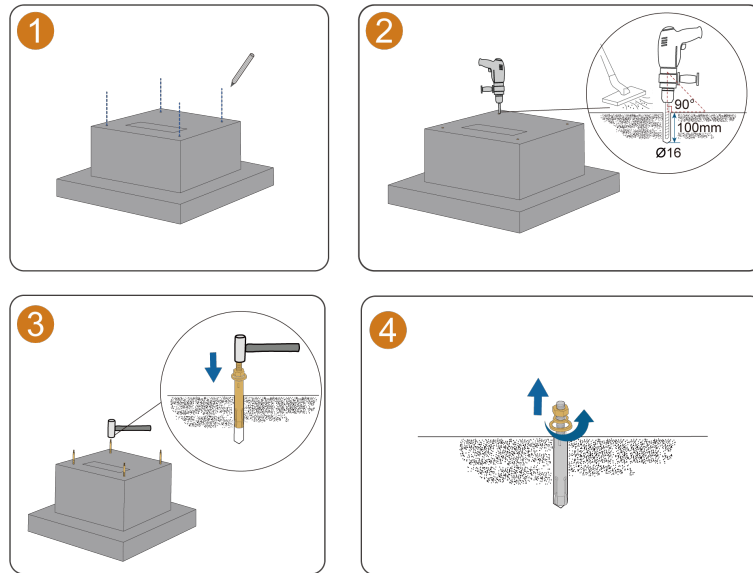

--End

4.4.2 Charger Handling



Improper handling may result in personal injury or device damage. For the safety of personnel and devices, it is recommended to use a forklift or crane for handling.

4.4.2.1 Handle with Crane

Requirements for Handling

Read through the information below if you are about to handle the charger with a crane.

- Use only specialized cranes that are operated by qualified personnel.
- The load capacity of the crane should meet the requirements of the product's specification.
- The slings must all have a tensile strength and length that meet the requirements.
- The lifting rings on the top of the product are firmly attached.
- No one is allowed to stay under the product when it is lifted up.
- When rotating the crane for unloading, keep it rotating at a low speed. Keep the product steady and as close to the ground as possible.
- Do not shake the slings during handling.
- Do not keep the product lifted up for a long period of time.
- Do not drag the product along any surface.

Tools

Item	Requirement	Source
Crane	Load carrying capacity $\geq 5000\text{kg}$.	Prepared by users

Item	Requirement	Source
Slings	2 slings; each has a lifting capacity of $\geq 2500\text{kg}$. The length between the lifting ring and the crane hook should be $\geq 1200\text{mm}$.	Prepared by users

Steps

Step 1 Remove the front and rear cover plates at the bottom of the charger.



Step 2 Remove the top cover of the charger and attach the steel wire rope slings to the lifting rings on the charger top, as shown in the figure below.

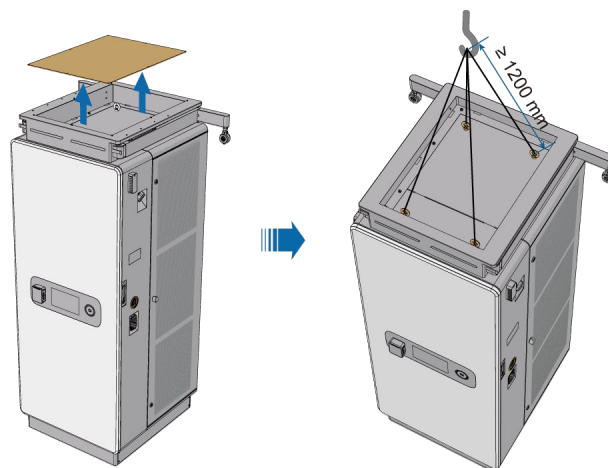

Step 3 Lift the charger vertically at an even speed. Make sure it is always held steady and does not tilt.

- Step 4** Suspend hoisting when the charger is lifted 100mm off the floor. Then, check that the connections between the slings and the charger are secure and that the stress is evenly applied to the lifting points.
- Step 5** After the charger is moved to a position over the top of foundation, lower it down steadily. Ensure the expansion bolt holes at the bottom of the charger align with the expansion bolts on the foundation.
- Step 6** When the charger is fully in contact with the foundation surface, remove the steel wire ropes.
- End

4.4.2.2 Handle with Forklift

Requirements for Handling

Read through the information below if you are about to handle the charger using a forklift.

- Use only specialized forklifts that are operated by qualified personnel.
- The carrying capacity of the forklift should meet the requirements of the product's specification.
- Make sure there are no obstacles, slopes, or other unevenness along the moving path of the product.

NOTICE

- Pay attention to the device's center of gravity at all times.
- A forklift with a load capacity of 5000kg is recommended.

- Step 1** Remove the front and rear cover plates at the bottom of the charger.



- Step 2** Adjust the spacing between and height of the forklift's forks, and drive slowly forward until the forks are fully inserted under the bottom of the charger.

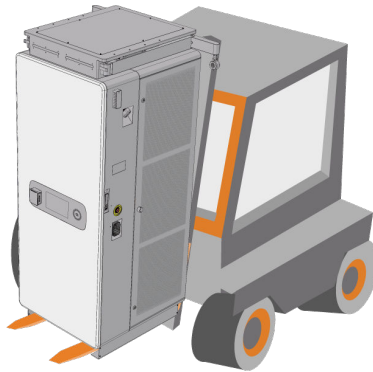

Step 3 Pick up the charger slowly, and drive the forklift to the foundation at a constant speed.

Step 4 Adjust the height of the forklift's forks. Ensure the expansion bolt holes at the bottom of the charger align with the expansion bolts on the foundation.

Step 5 When the charger is fully in contact with the foundation surface, move away the forks slowly.

--End

4.4.3 Charger Mounting

Step 1 Move the charger to the foundation using a crane (refer to [4.4.2.1 Handle with Crane](#)) or a forklift (refer to [4.4.2.2 Handle with Forklift](#)).

Step 2 Attach the flat washer, spring washer, and nut to the expansion screw in the correct order. Then, tighten the screws using a socket wrench. An S10 (M12) socket wrench is recommended.

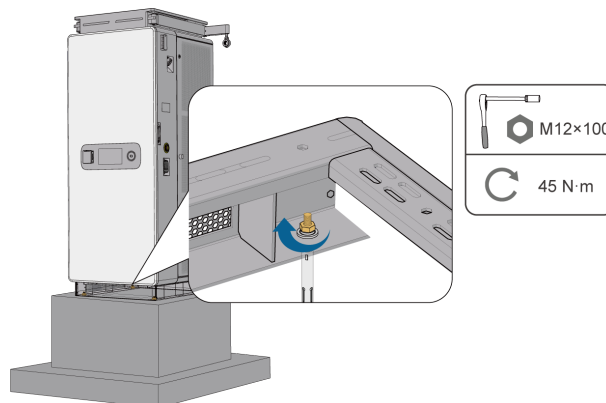

Step 3 If a crane is used for installation, reinstall the top cover.

--End

5 Electrical Connection

5.1 Cable Requirement

Before proceeding with the electrical connection, prepare the cables, terminals, and other items that are required.

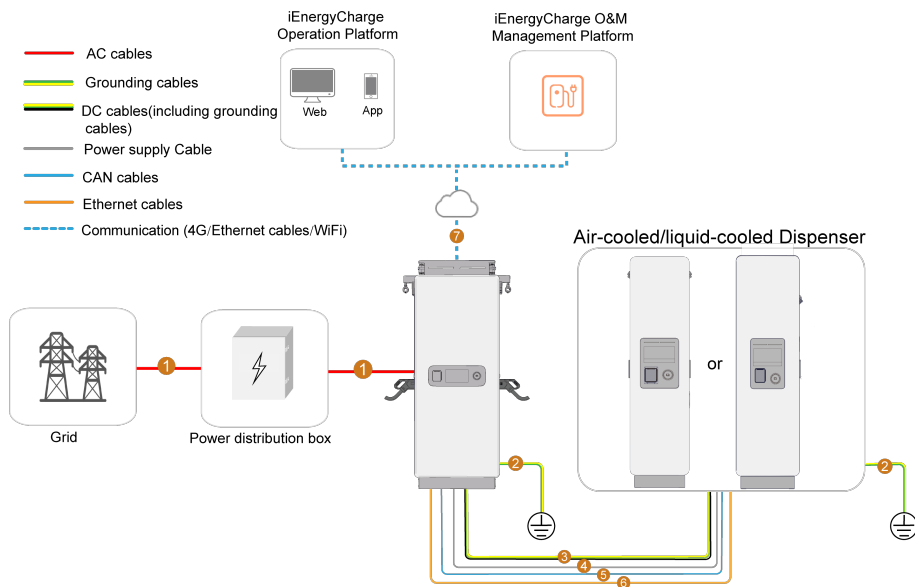

i The maximum allowable communication distance between the charger and the dispenser is 80 meters under standard operating conditions.

Cable Specifications

The cables should be prepared separately by users. Recommended cable specifications are listed in the table below.

Table 5-1 Cable Specifications

No	Cable	Type	Wire cross-sectional area (mm ²)	Crimp Terminal
1	AC cables (two inputs)	Outdoor single-core copper cable Withstand voltage: 1kV	L1, L2, L3: 150mm ² N: 150mm ² PE: 95mm ²	L1, L2, L3: SC150-10 N: SC150-8 PE: SC95-8

No	Cable	Type	Wire cross-sectional area (mm ²)	Crimp Terminal
		Outdoor five-core copper cable Withstand voltage:1 kV	L1,L2,L3: 185 mm ² N: 185 mm ² PE: 95 mm ²	L1, L2, L3: SC185-10 N: SC185-8 PE: SC95-8
		Outdoor single-core aluminum cable Withstand voltage: 1kV	L1, L2, L3: 240mm ² N: 240 mm ² PE: 120mm ²	L1, L2, L3: SC240-10 N: SC240-8 PE : SC120-8
		Outdoor five-core aluminum cable Withstand voltage:1 kV	L1,L2,L3: 300 mm ² N: 300 mm ² PE: 150 mm ²	L1, L2, L3: SC300-10 N: SC300-8 PE :SC150-8
2	Grounding flat steel	Hot-dip galvanized flat steel	40 mm×4 mm	-
3	DC cables (including grounding cables) between charger and air-cooled dispenser	Outdoor single-core copper cable Withstand voltage: 1kV	DC1+,DC2+,D C1-,DC2-: 150mm ² PE: 95mm ²	DC1+,DC2+,D C1-,DC2-: SC150-10 PE: SC95-8
		Outdoor five-core copper cable Withstand voltage:1 kV	DC1+,DC2+,D C1-,DC2-: 185mm ² PE: 95mm ²	DC1+,DC2+,D C1-,DC2-: SC185-10 PE: SC95-8
		Outdoor single-core aluminum cable Withstand voltage: 1kV	DC1+,DC2+,D C1-,DC2-: 240 mm ² PE: 120 mm ²	DC1+,DC2+,D C1-,DC2-: SC240-10 PE: SC120-8
		Outdoor five-core aluminum cable Withstand voltage:1 kV	DC1+,DC2+,D C1-,DC2-: 300 mm ² PE: 150 mm ²	DC1+,DC2+,D C1-,DC2-: SC300-10 PE: SC150-8

No	Cable	Type	Wire cross-sectional area (mm ²)	Crimp Terminal
	DC cables □including grounding cables□between charger and liquid-cooled dispenser	Outdoor single-core copper cable Withstand voltage: 1kV	DC1+,DC2+,D C1-,DC2-: 120mm ² PE: 70mm ²	DC1+,DC2+,D C1-,DC2-: SC120-10 PE: SC70-8
		Outdoor five-core copper cable Withstand voltage:1 kV	DC1+,DC2+,D C1-,DC2-: 150mm ² PE: 95 mm ²	DC1+,DC2+,D C1-,DC2-: SC150-10 PE: SC95-8
		Outdoor single-core aluminum cable Withstand voltage: 1kV	DC1+,DC2+,D C1-,DC2-: 185 mm ² PE: 95 mm ²	DC1+,DC2+,D C1-,DC2-: SC185-10 PE: SC95-8
		Outdoor five-core aluminum cable Withstand voltage:1 kV	DC1+,DC2+,D C1-,DC2-: 240 mm ² PE: 120 mm ²	DC1+,DC2+,D C1-,DC2-: SC240-10 PE: SC120-8
4	Power cable between charger and air-cooled/ liquid-cooled dispenser	Two-core power cable	2.5mm ²	E1510
5	Communication cable (CAN) between charger and air-cooled/ liquid-cooled dispenser	Shielded twisted pair	0.75mm ²	E1510
6	Network cable between charger and air-cooled/ liquid-cooled dispenser	8-core Cat5e or Cat6 Ethernet cable	-	-

No	Cable	Type	Wire cross-sectional area (mm ²)	Crimp Terminal
7	Network cable(Communication)	8-core Cat5e or Cat6 Ethernet cable	-	-



- All cable specifications listed in this manual are recommended values. Users must select appropriate cables based on actual conditions and ensure compliance with local regulations and safety standards.
- The cable specifications recommended in the table are only applicable to cable duct installations. For other installation methods, please select the appropriate cable specifications based on local conditions.
- To avoid wiring errors that may cause device malfunction, it is recommended to clearly label both ends of each cable (e.g., using adhesive labels) before cable routing, and to double-check all connections before and after wiring.

After leading the cable through the cable inlet, crimp the terminal onto the cable, so as to ensure reliable connections, refer to [5.2 Wiring Terminals Preparation](#) . Poor contact may lead to overheating or even safety incidents.

Copper wires are recommended. If aluminum wires are selected, use copper-aluminum bimetallic terminals, avoiding direct contact between the copper bar and the aluminum wire.

5.2 Wiring Terminals Preparation

5.2.1 Crimp OT/DT/SC terminal

Crimp OT/DT/SC terminal

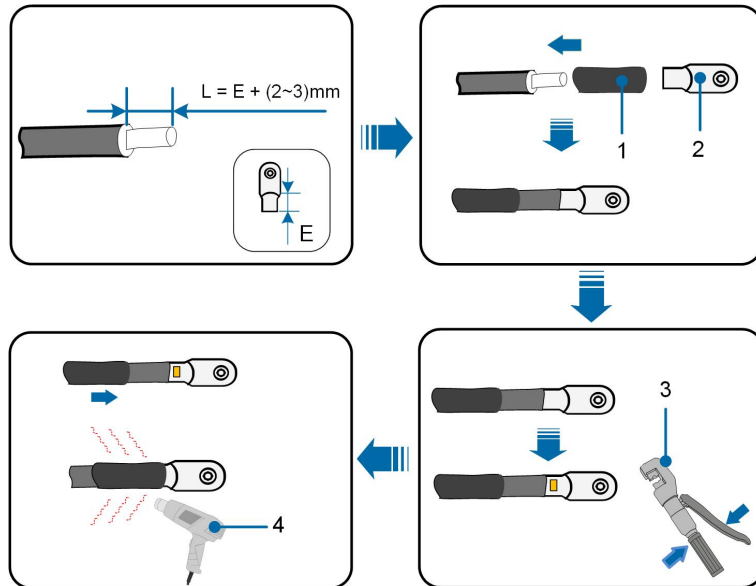

Before crimping the terminals, slide heat shrink tubing over the crimping area, ensuring full coverage. After crimping, use a heat gun to evenly heat the tubing until it tightly adheres to the terminals. This prevents loosening, oxidation, or short circuits, ensuring a secure and reliable connection.

1. Heat shrink tubing

2. OT/DT/SC terminal

3. Hydraulic pliers

4. Heat gun

Aluminum Cable Requirements

If an Aluminum cable is selected, use a copper-aluminum bimetallic terminal, avoiding direct contact between the copper bar and the aluminum wire.

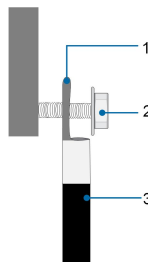

Figure 5-1 Aluminum Cable Connection

1. Copper-aluminum bimetallic terminal

2. Flange nut

3. Aluminum cable

NOTICE

Ensure that the selected terminal can directly contact with the copper bar. If there are any problems, contact the terminal manufacturer.

Ensure that the copper bar is not in direct contact with the aluminum wire. Otherwise, electrochemical corrosion may occur, impairing the reliability of electrical connection.

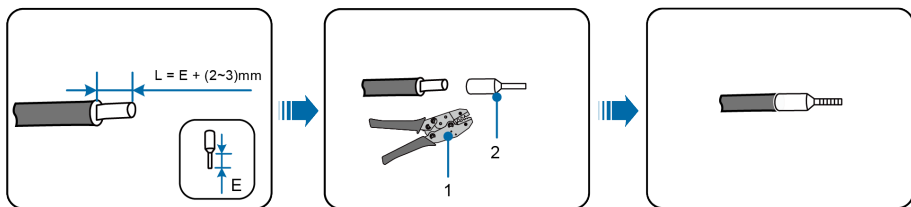
5.2.2 Crimp Cord-end Terminal**Crimp Cord-end Terminal**

(1) Crimp tool

(2) Cord-end terminal

5.3 External ground Connection

Non-current carrying metal parts and device enclosures in the electric power system should all be grounded.

The copper bar provided on the back of the charger is used for grounding.

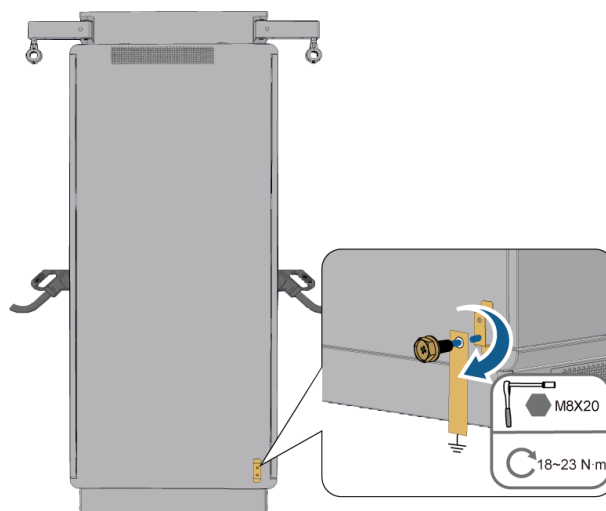

- Step 1** Securely connect the external grounding copper bar of the device to one end of the grounding flat steel.
- Step 2** Ensure that the other end of the grounding flat steel is firmly connected to the grounding system. It is recommended to bury it deep underground. If burial or burial at the required depth is not feasible, implement an appropriate grounding method based on the actual site conditions.



- The grounding flat steel needs to be prepared by the user.
- The grounding system must comply with local electrical regulations to ensure safe operation.

--End

5.4 AC Cable Connection

The AC cable is used to connect the charger to the grid, so that the grid can supply electricity to the charging system.

DANGER

- Do not connect the AC cable when the device carries voltage; otherwise, it may result in personal injury.
- Do not power the device before the AC cable connection and cable laying are completed.

NOTICE

- Connect the cables in the proper order to the correct positions. Failure to do so may damage the device and such damages will not be covered by the warranty.
- The device has two AC inputs. Make sure they are both connected.



- The cable colors in the figures in this manual are for reference only. Please select cables according to local cable codes.
- When the product is connected to a dispenser, for ease of installation, it is recommended to first refer to [5.6.1 DC Cable and Grounding Cable Connection](#) to connect the DC and grounding cables between the product and the dispenser, then proceed with the AC cable connections as described in this section.

- Step 1** Ensure the circuit breaker between the charger and the grid is in the open state and will not be closed by accident.
- Step 2** Open the front door of the charger.
- Step 3** Make sure the charger's MCCB is set to "OFF".

- Step 4** Crimp the terminal onto the AC cable by referring to [5.2.1 Crimp OT/DT/SC terminal](#).
- Step 5** Trim the seal of the waterproof sealing plate to make AC cable inlet at the internal bottom of the charger, which should be done properly according to the outer diameter of the AC cable.
- Step 6** Lead the AC cable out from the conduit and pass it through the AC cable inlet at the internal bottom of the charger.
- Step 7** Use a wrench to secure the cables of two AC inputs to the designated terminals, by referring to the figure below. For easier connection, start by connecting the cables to the inner N and PE copper bars, then connect the L1, L2, and L3 cables to the outer terminals.

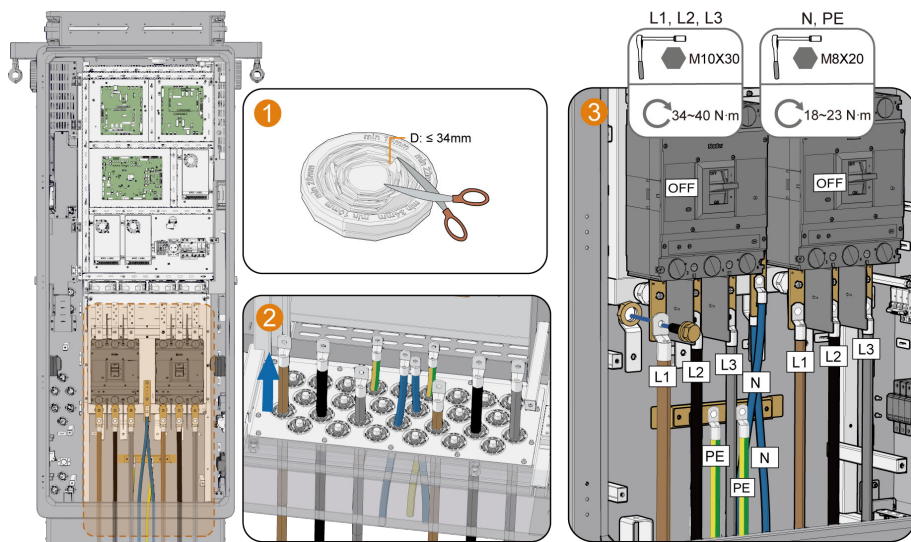

--End

5.5 Charger Network Connection

5.5.1 Communication Interfaces

The charger supports 4G, Ethernet and Wi-Fi network. Communication data is transmitted to the cloud platform to facilitate operation and maintenance by qualified personnel. A SIM card is required to enable 4G wireless communication, while connecting the charger to a router with a network cable is required to enable Ethernet communication.

The charging management platform is a cloud platform incorporating functions of monitoring, operation, and management. Users can manage and maintain their devices on this platform, with functions such as charging authorization, order management, and remote fault troubleshooting. The device communicates with the charging management platform over the OCPP protocol. OCPP (Open Charge Point Protocol) defines the protocol standard for network interconnection between the charger and the charging management platform.

Table 5-2 Hardware Interfaces

Interfaces	Visible	Use Case
Ethernet interface	Y	Network Communication
4G Communication Slot	Y	4G Communication
Wi-Fi interface	N	Communication via Wi-Fi

Table 5-3 Supported Communication Protocols

Protocols	Description
HTTP+TLS	OCPD server connection; WiFi module and App connection
LTE	4G SIM card communication
Modbus	Communication based on MbedTLS

The charger operates a web service via port 8089, providing a browser-based interactive management interface. Users can access this interface to perform system management tasks, including login, network configuration, device status monitoring, OCPP protocol settings, certificate management, charging parameter configuration, system reboot, SSH service management, and data traffic monitoring.

4G and Ethernet communication is recommended. The parameters required for each type of network connection are detailed in the table below.

Table 5-4 Supported Network Connection Methods

Communication Method	Technical Data	Connection Method
4G	Frequency Band: <ul style="list-style-type: none"> • LET-FDD: Band 1/3/7/8/20/28A • LTE- TDD: Band 38/40/41 • WCDMA: Band 1/8 • GSM: Band 3/8 Transmitting Power: <ul style="list-style-type: none"> • LET-FDD (Band 1/3/7/8/20/28A): 23dBm-2dB/23dBm+2dB • LTE-TDD (Band 38/39/40): 23dBm-2dB/23dBm+2dB • GSM (Band 3): 26dBm • GSM (Band 8): 	SIM card
Ethernet	Rate (Mbit/s): 10/100 self-adaptive	Ethernet interface

During high network traffic conditions, the device will enter a protection mode and activate rate limiting measures. There are three types of protection mechanisms:

- **IP-Based request rate limiting**
Each accessing IP address is assigned a separate token bucket. Up to 10 tokens are replenished per minute, with a maximum capacity of 60 tokens. Each API request consumes one token. Once the tokens are depleted, any further requests from that IP will be directly rejected.
- **Global request rate limiting**
The system maintains a global token bucket to limit the total number of requests from all IP addresses. The global limit is set at 200 requests per minute. Any requests exceeding this limit will be uniformly rejected to prevent system overload.
- **IP blacklisting mechanism**
If an IP address repeatedly triggers request denials within a short period (i.e., continues sending requests after exhausting its tokens), the system will blacklist the IP. While blacklisted, the IP address will be denied access to all API endpoints for 5 minutes. After the ban period ends, the system will automatically remove the IP from the blacklist, allowing access to resume.

Network Traffic Monitoring Panel Overview

- **Start/Stop toggle:** Activates or halts network monitoring.
- **Monitoring indicator (green):** Indicates that network monitoring is active.
- **Update interval:** Sets the refresh interval for the displayed data.
- **Black terminal window:** Displays real-time connection and traffic statistics for the current network interface (e.g., wlo1).
- **Host name (port/service if enabled):** Displays the hostname or IP address of the connected devices.
- **=> / <= Symbols:** Indicate the direction of data transmission (send/receive).
- **Last 2 s / 10 s / 40 s:** Shows the amount of data transmitted in the past 2, 10, and 40 seconds, respectively.
- **Cumulative:** Displays the total traffic since monitoring activation.



Hereby, Sungrow Power Supply Co.,Ltd. declares that this radio equipment is in compliance with Directive 2014/53/EU.

5.5.2 SIM Card Installation

Required Materials

- Industrial-grade IoT SIM cards with a size of 2FF 25mm*15mm

Step 1 Open the front door of the charger.

Step 2 Use the ejector pin (prepared by the user separately) to pop open the SIM card tray of SIM1 port.

Step 3 Put the SIM card on the card tray and align it with the card slot on the front door.

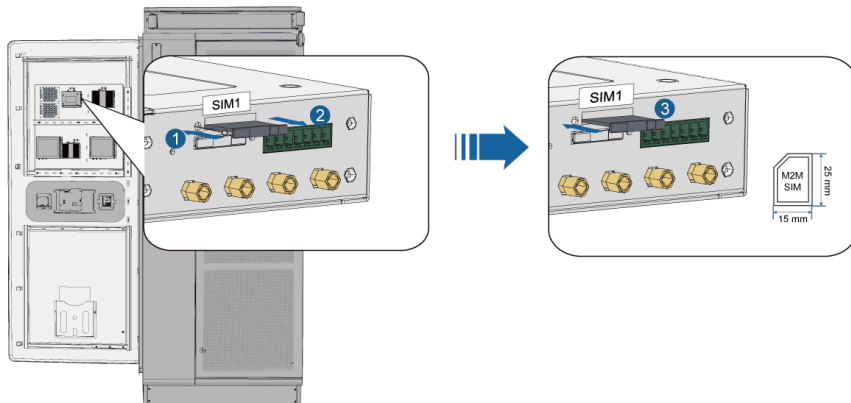

Step 4 Push the SIM card gently into the slot until it is in place. Do not exert too much pressure, to avoid card deformation or damage.



- The SIM card should be prepared separately by the user.
- Select an appropriate data plan based on the number of devices in the charging system. It is recommended to allocate 500MB/month per device (e.g., for a system with 1 charger and 1 dispenser, a 1GB/month data plan is suggested).
- If the monthly data limit is exceeded, the device will be disconnected from the network. Ensure timely purchase of additional data to restore connectivity.

--End

5.5.3 Ethernet Cable Connection

Required Materials

- 8-core Cat5e or Cat6 Ethernet cable



The Ethernet cable should be prepared separately by the user.

Step 1 Open the front door of the charger.

Step 2 Trim the seal of the waterproof sealing plate to make Ethernet cable inlet at bottom of the charger, which should be done properly according to the outer diameter of the Ethernet cable.

Step 3 Insert the RJ45 plug of the Ethernet cable into the network port (WAN port) of router on the front door.

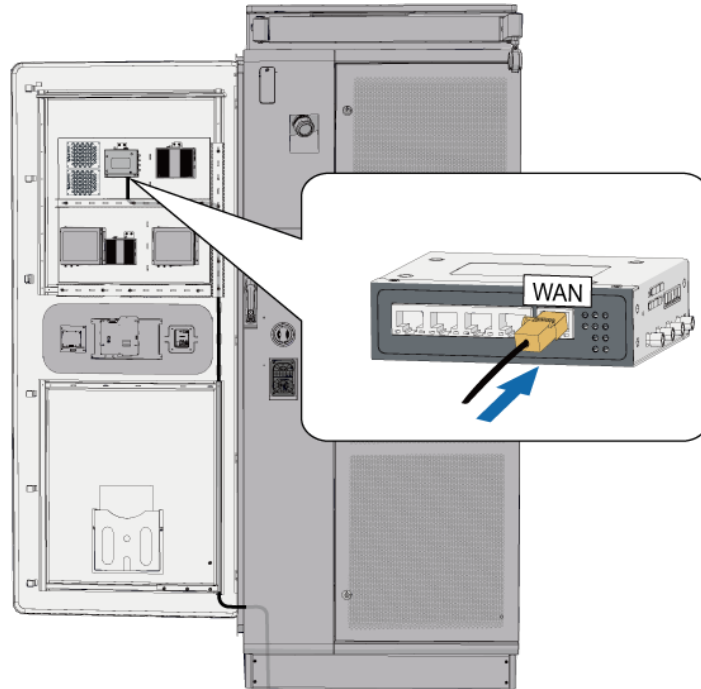

Step 4 Upon hearing an audible “click”, pull the network cable gently backward and make sure the connection is secure.

--End

5.6 Electrical Connection with Dispenser (Optional)



When connecting the product to the dispenser, refer to this section to complete the cable connections on the product side. For detailed operations on the dispenser side, see the corresponding dispenser manual.

5.6.1 DC Cable and Grounding Cable Connection

Step 1 Ensure the circuit breaker between the charger and the grid is in the open state and will not be closed by accident.

Step 2 Open the front door of the charger.

Step 3 Make sure the charger’s MCCB is set to “OFF”.

Step 4 Crimp the terminal onto the DC cable and grounding cable by referring to [5.2.1 Crimp OT/DT/SC terminal](#).

Step 5 Trim the seal of the waterproof sealing plate to make DC cable inlet and grounding cable inlet at the internal bottom of the charger, which should be done properly according to the outer diameter of the DC cable and grounding cable.

Step 6 Lead the DC cable and grounding cable out from the conduit and separately pass them through the DC cable inlet and grounding cable inlet at the internal bottom of the charger.

Step 7 Use a wrench to connect the grounding cable to the inner PE copper bar. Then connect the DC+ cable to the corresponding position in the outer DC+ wiring area, and DC- cable to the corresponding position in the outer DC- wiring area.

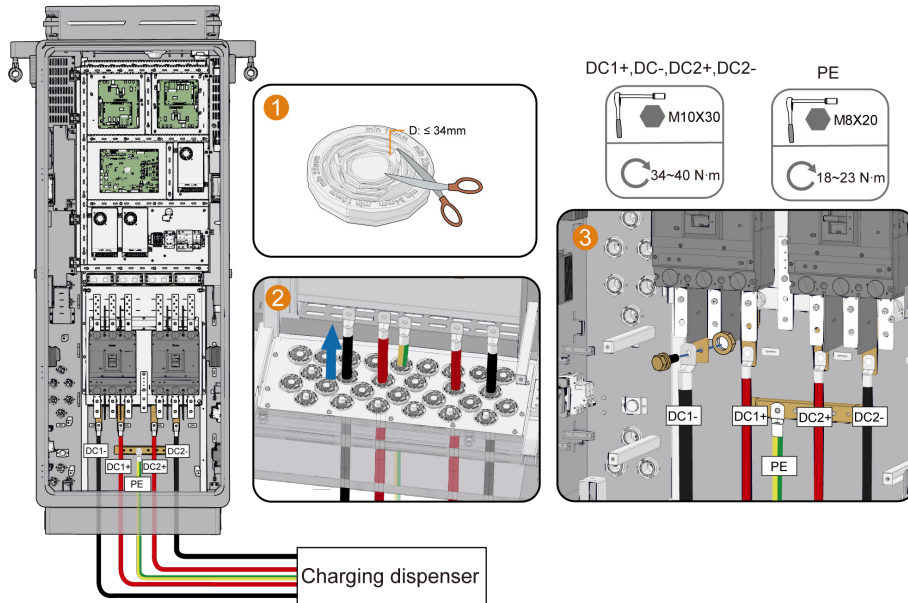

Follow the wiring rules outlined in the table below to establish the DC connections between the charger and dispenser. Configure the corresponding the dispenser and connectors according to the dispenser type.

Table 5-5 Rules for DC Wiring Between Charger and Dispenser

Dispenser Type	Charging Connector ID	Connection Points
Air-cooled dispenser	GUN3	DC1+/DC1-: DC1+ / DC1-
	GUN4	DC2+/DC2-: DC2+ / DC2-
Liquid-cooled	GUN3	DC1+ / DC1-: DC1+ / DC1- DC2+ / DC2-: DC1+ / DC1-

⚠ CAUTION

Ensure the DC+ and DC- cables are all connected in the correct positions, otherwise, the device cannot operate properly.

Step 8 Lead the other end of the DC cable and grounding cable through the cable inlet on the dispenser and connect them to the designated position .

--End

5.6.2 Power Cable Connection

The charger is connected to the dispensers with power cables so that it can supply power to the dispensers.

- Step 1** Crimp the cord-end terminal on the power cable by referring to [5.2.2 Crimp Cord-end Terminal](#).
- Step 2** Trim the seal of the waterproof sealing plate to make power cable inlet at the internal bottom of the charger, which should be done properly according to the outer diameter of the power cable.
- Step 3** Lead the power cable out from the conduit and pass it through the cable inlet at the internal bottom of the charger. Then, connect the cable to the designated power supply wiring terminal.

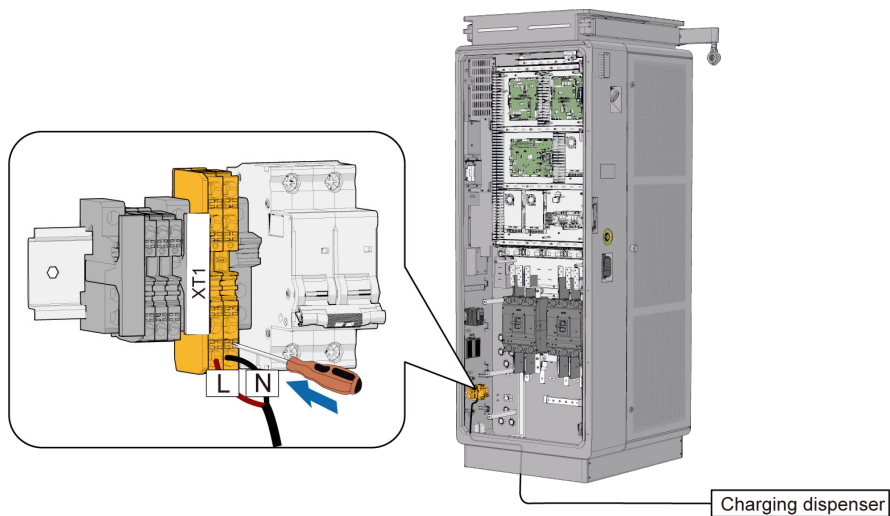

Table 5-6 Connections Between Charger and Dispenser

Connection Point	Dispenser
XT1	Air-cooled/Liquid-cooled dispenser

- Step 4** Connect the other end of the power cable to the designated wiring terminal on the dispenser.

--End

5.6.3 CAN Cable Connection

The charger is connected to the dispenser with a CAN cable for communication.

- Step 1** Crimp the cord-end terminals onto the wires of the CAN cable by referring to [5.2.2 Crimp Cord-end Terminal](#).
- Step 2** Trim the seal of the waterproof sealing plate to make CAN cable inlet at the internal bottom of the charger, which should be done properly according to the outer diameter of the CAN cable.

Step 3 Lead the communication cable out from the conduit and pass it through the cable inlet at the bottom of the charger. Then, connect its wires to the designated CAN wiring terminals.

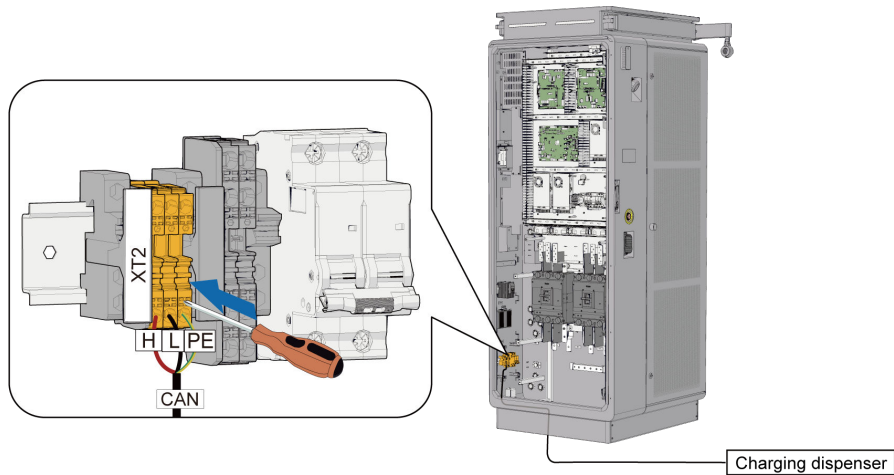

Table 5-7 Connections Between Charger and Dispenser

Connection Point	Dispenser
XT2	Air-cooled/Liquid-cooled dispenser

i The CAN cable must be a twisted shielded pair (refer to [5.1 Cable Requirement](#) for specifications). The shielding layer must be properly grounded.

Step 4 Connect the other end of the CAN cable to the designated wiring terminal on the dispenser.
--End

5.6.4 Dispenser Network Connection

Required Materials

- 8-core Cat5e or Cat6 Ethernet cable

i The Ethernet cable should be prepared separately by the user.

Step 1 Open the front door of the charger.

Step 2 Trim the seal of the waterproof sealing plate to make Ethernet cable inlet at bottom of the charger, which should be done properly according to the outer diameter of the Ethernet cable.

Step 3 Insert the RJ45 plug of the Ethernet cable into the network port of the switch on the internal left side of the charger.

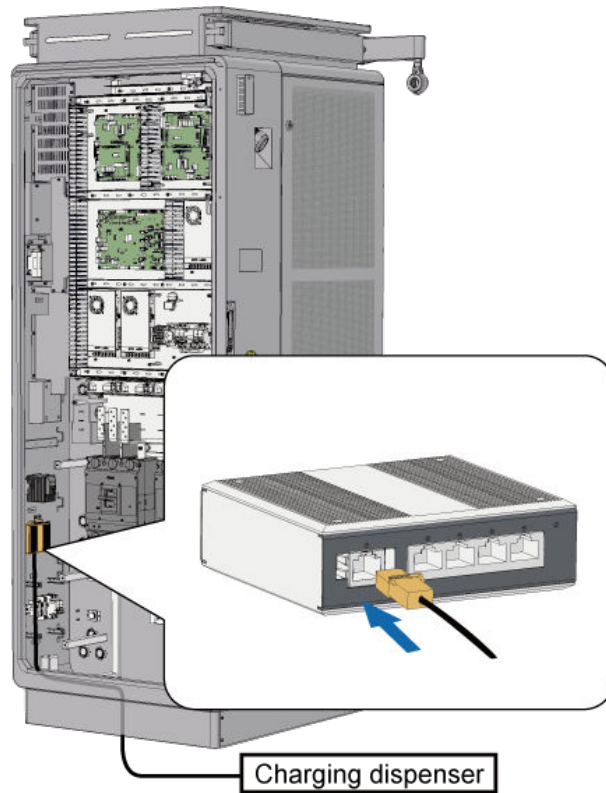

Step 4 Upon hearing an audible “click”, pull the network cable gently backward and make sure the connection is secure.

Step 5 Connect the other end of the Ethernet cable to the designated wiring port on the dispenser.

--End

6 Commissioning

6.1 Inspection Before Commissioning

To ensure safe use, please perform the following inspections on the device before powering it on.

⚠ CAUTION

Do not power the device unless the inspections are completed.

Table 6-1 Inspection Items

Item	Methods/Tools	Requirements
Device inspection	Visual Inspection	<ul style="list-style-type: none">• No visible scratch on or deformation on the enclosure.• No paint peeling on the exterior.• The parts and components of the device are secure and reliable, and the nameplate and marks are all legible.• The device is installed in an environment where heat can be well dissipated, without any clutter piled on its top or around it.
Charging connector inspection	Visual Inspection	<ul style="list-style-type: none">• No wet spots or foreign matters on the charging connector.• The charging cable is intact.
Power supply cable inspection	Multimeter/ screwdriver	<ul style="list-style-type: none">• The three-phase power supply cable is securely attached to the MCCB.• The grounding cable is securely and properly connected to allow for effective grounding.• The screws for the input cable are fastened.• Check if there is short-circuit in the AC/DC circuits using a multimeter.• Check if the supply voltage is within the input voltage range allowed for the device using a multimeter.

Item	Methods/Tools	Requirements
Electric vehicle (EV) inspection	Visual Inspection	<ul style="list-style-type: none"> The EV is parked in the designated place. The EV sits perfectly still.

6.2 Commissioning Steps

Ensure the device has been properly installed and the pre-commissioning inspection items all meet the requirements. Power on and commission the device first before putting it into operation.

DANGER

- Do not touch any live part of the product when it is running; otherwise, it may lead to electrical shocks.
- Do not touch any wiring terminal on the product when it is running; otherwise, it may lead to electrical shocks.
- Do not remove any part or component from the product when it is running; otherwise, it may lead to electrical shocks.

Step 1 Switch on the upstream circuit breaker.



For the upstream circuit breaker, use a 3P molded case circuit breaker without residual current protection, or a 3P+N molded case circuit breaker with residual current protection.

Step 2 Before switching on the circuit breaker inside the charger, measure the voltage of the copper bars of the two inputs by following the instructions below, and ensure the input voltage is in normal range.

Test point 1	Test point 2	Normal voltage range
L1	L2	360–440V
L1	L3	
L2	L3	
L1	N	208–254V
L2	N	
L3	N	

Step 3 Switch on the MCCB, SPD circuit breaker, charger internal power supply MCB, and fan power supply MCB in sequence.

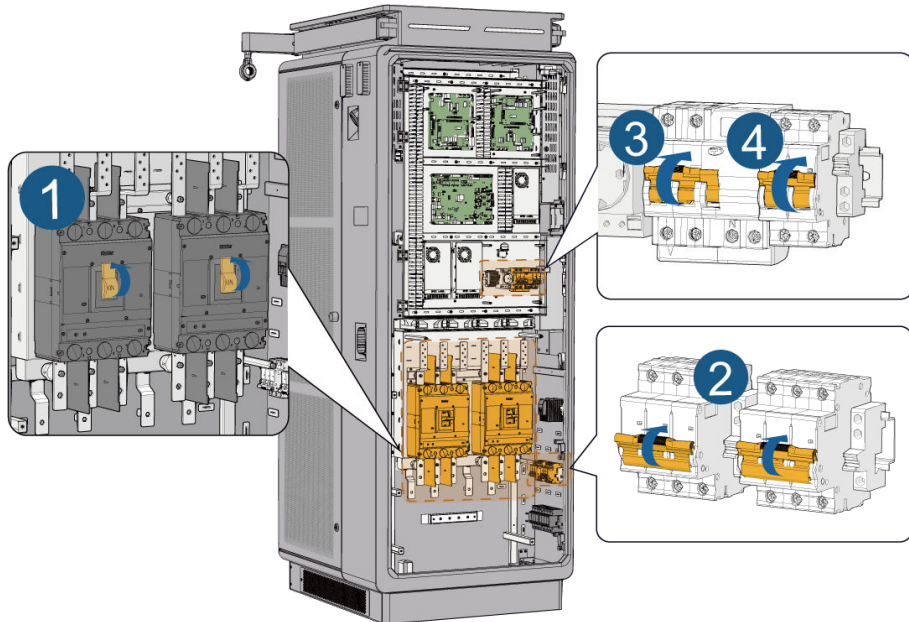

Step 4 (Optional) When connecting to the dispenser, switch on the dispenser power supply MCB; otherwise, skip to the next step.

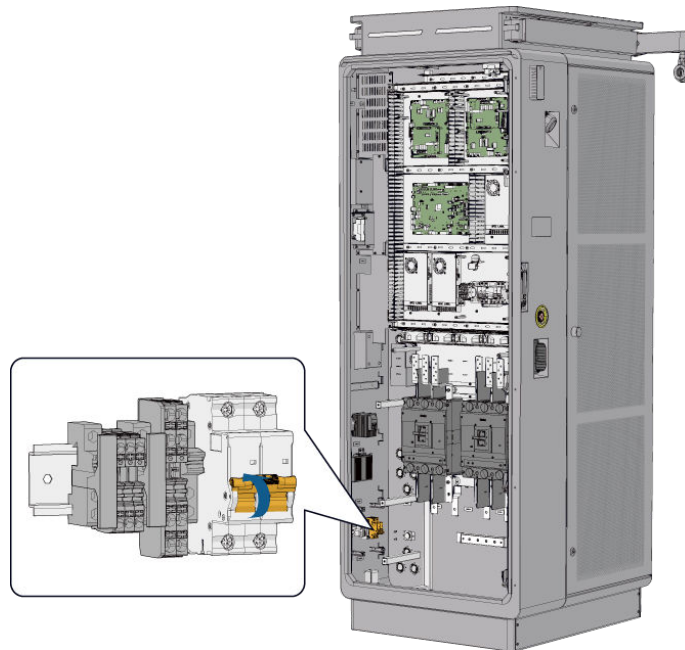

Step 5 Close all doors and check the Energy-Star Ring indicator on the front door and the LED indicator at the top of charger. If the LED indicator is steady green, the charging connector is in standby mode; if the Energy Star-Ring is steady blue, the charger is working normally.

Step 6 Check the screen. The system will run a self-check, which takes about 30 seconds.

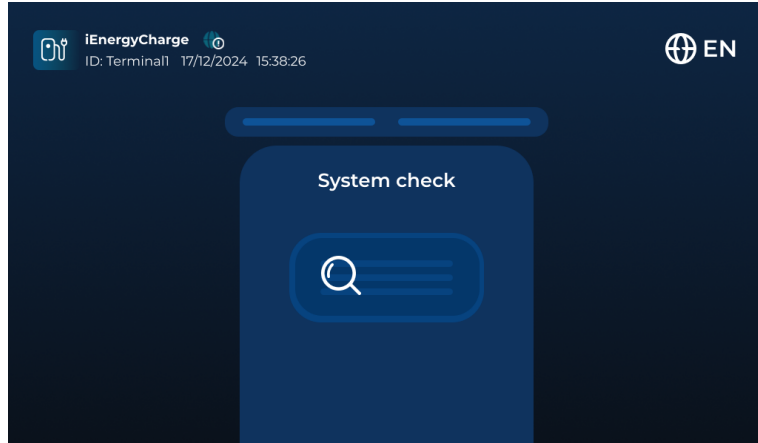

Step 7 After the system check is finished, the Authentication Method Selection Page will be shown. You can select a charging method as needed.

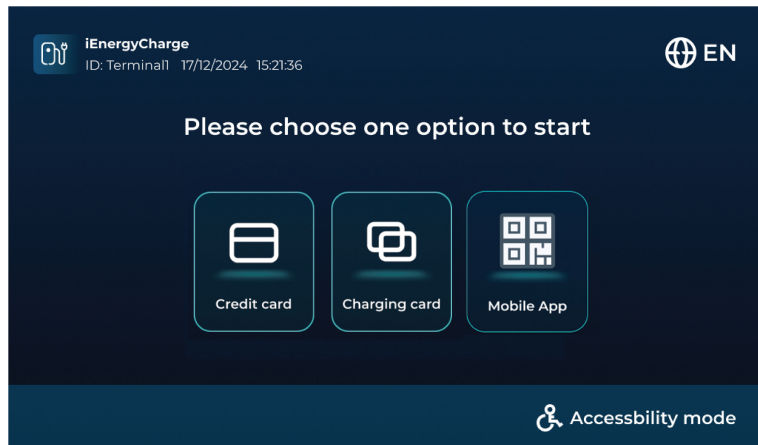

Step 8 Taking the RFID card as an example, if you choose "RFID", the Energy Star-Ring on the device will blink blue, waiting for you to tap a card over the card reader. Upon detecting the card, the system will verify its validity. If it is valid, an authentication success message will show up, and you will then go to the Connector Selection Page.

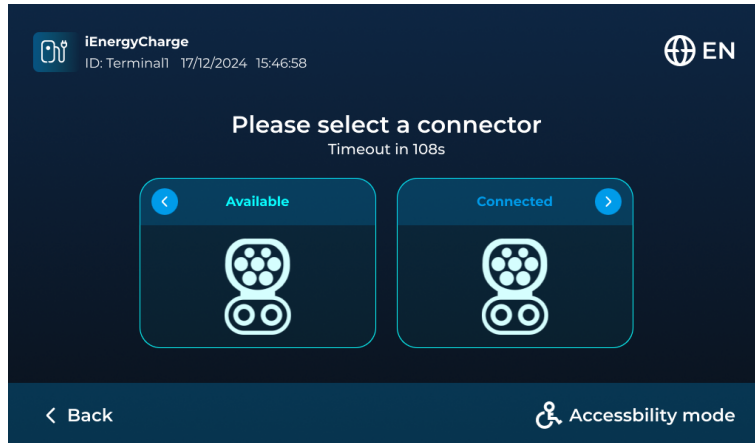

Step 9 Take down the charging connector you have selected, and plug it into the charging port on the EV. Make sure the connection is secure.

Step 10 After the charging is completed, put the charging connector back into the charger. Prevent the charging connector from getting in contact with heat, dirt, or water.



In case of an emergency, you can press the emergency stop button on the side of the device to stop charging immediately.

Step 11 (Optional) when connecting to the dispenser, perform charging commissioning by referring to the commissioning instructions specified for the dispenser after completing the above steps.

--End

6.3 Post-Commissioning Operations

Step 1 Refer to [9.2 Power off the Charger](#) to power off both the charger and the dispenser.

Step 2 Use fireproof mud (from the shipping accessories) to seal the gaps around the cable inlet/outlet holes.



- Fireproof and waterproof materials (e.g., fireproof mud) must be used to seal all gaps around the cable inlet/outlet holes to prevent foreign objects or moisture ingress, which could compromise the charger's long-term stable operation.
- If the mud has hardened, gently heat it with a heat gun to soften it before use.

Step 3 Reinstall the protective covers for the DC and AC wiring compartments into the cabinet.

Step 4 Close all cabinet doors and store the keys properly.



Before closing the doors, ensure all tools, metal parts, and debris are removed from the interior.

Step 5 Install the cover plate at the bottom of the charger and clean the site.

--End

7 LCD Touch Screen

7.1 Charging Procedure

The product's touch screen serves as an interface for human-machine interaction. You can perform various operations on the device via the touch screen, e.g., starting or stopping charging, viewing the charging data, and performing fault diagnosis.

The flow chart of a charging session is shown as follows:

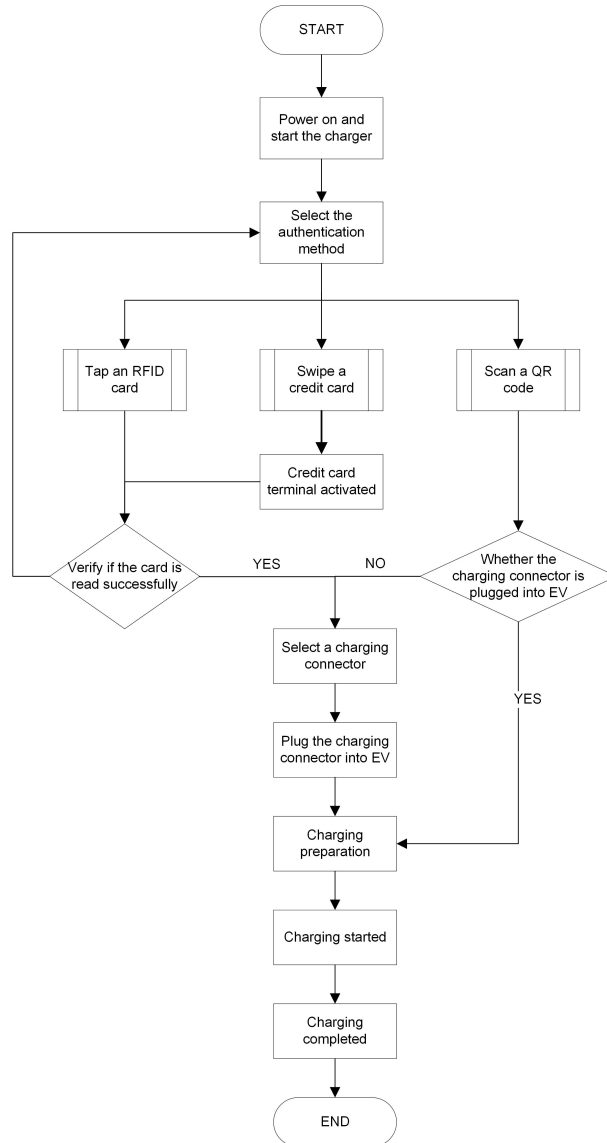

7.1.1 Select an Authentication Method

When the product is powered on, the system will run a self-check. After the system check is finished, the Authentication Method Selection Page will appear as shown below:

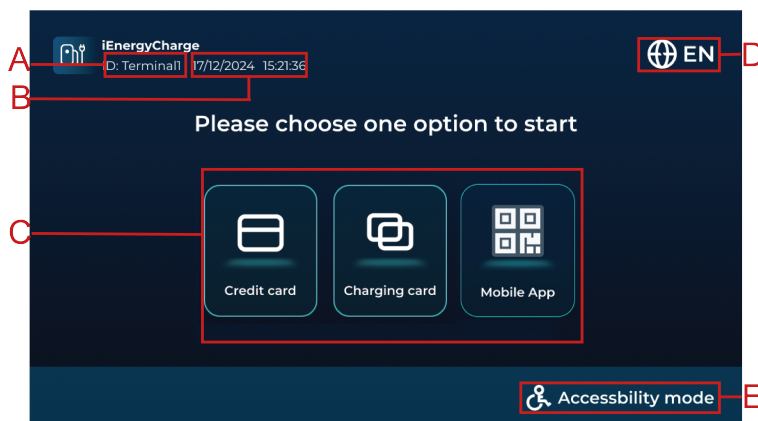

No.	Description
A	Product ID, an unique identifier for the product.
B	Current date and time.
C	<p>Three authentication methods available:</p> <ul style="list-style-type: none"> • Charging Card (RFID) • Credit Card • Mobile APP (iEnergyCharging Code) <p>Choose one authentication method for each charging session.</p>
D	Language switch button, used to switch between multiple languages, with English as the default.
E	Accessibility mode button, used to move down language options for easier access.

Choose your preferred authentication method.

Option 1: Charging Card (RFID)

Tap **Charging Card** and place the RFID card against the Energy Star-Ring (card reader). The system will verify its validity.

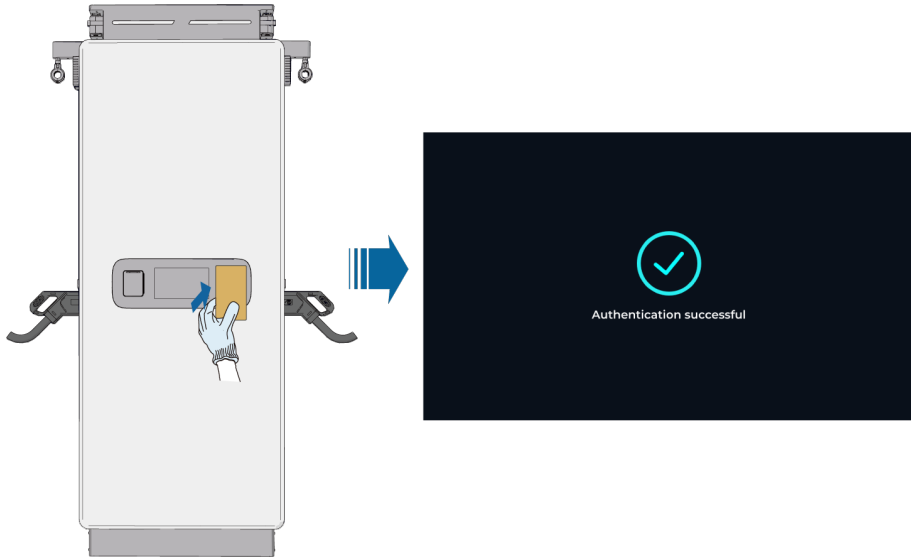

- If it is valid, the system will proceed to the Connector Selection Page. If the charging connector is already plugged in, the system will take you to the Charging Details Page directly.
- If verification fails, the card may not be activated or could be demagnetized. Tap **Back** and choose another authentication method.

Option 2: Credit Card

Tap **Credit Card** and place the credit card against the Energy Star-Ring (card reader).

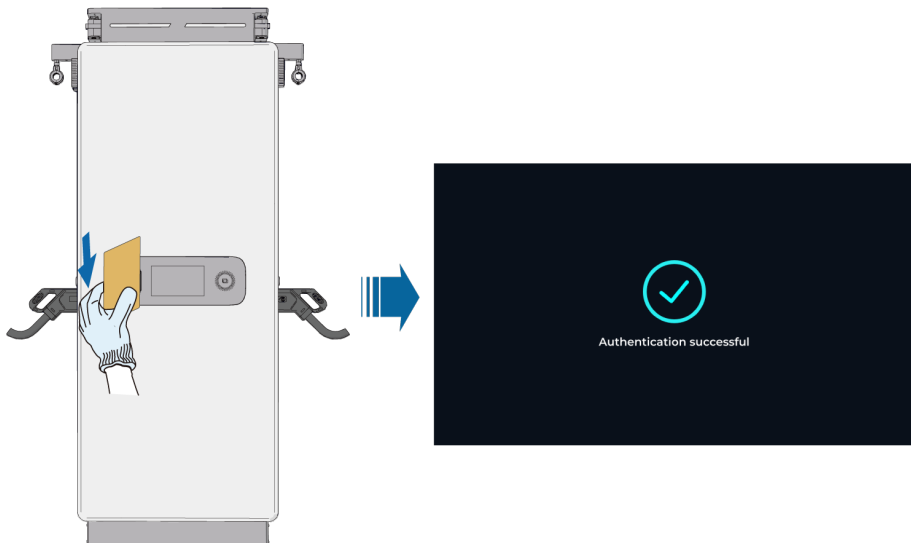

- If it is valid, the system will proceed to the Connector Selection Page. If the charging connector is already plugged in, the system will take you to the Charging Details Page directly.
- If verification fails, the card may not be activated or could be demagnetized. Tap **Back** and choose another authentication method.

Option 3: Mobile APP (iEnergyCharge APP)

Tap **Mobile App** to begin. Open the iEnergyCharge mobile app and scan the QR code of the desired charging connector to go to the Connector Selection Page. If the charging connector is already plugged in, the system will take you to the Charging Details page directly.

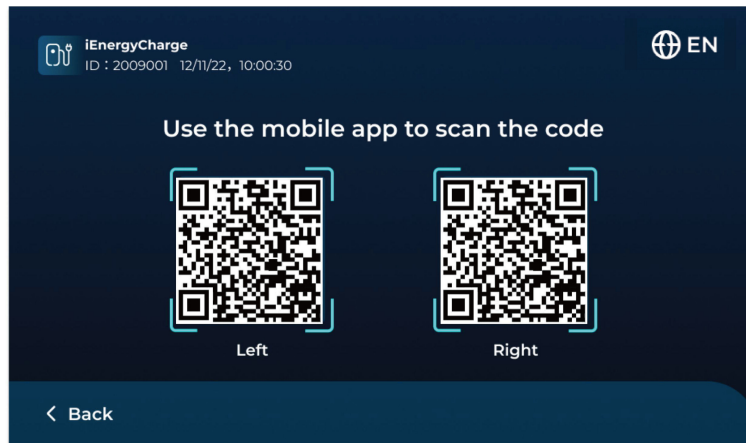

7.1.2 Select a Charging Connector

The product allows two connectors to operate independently, without interference.

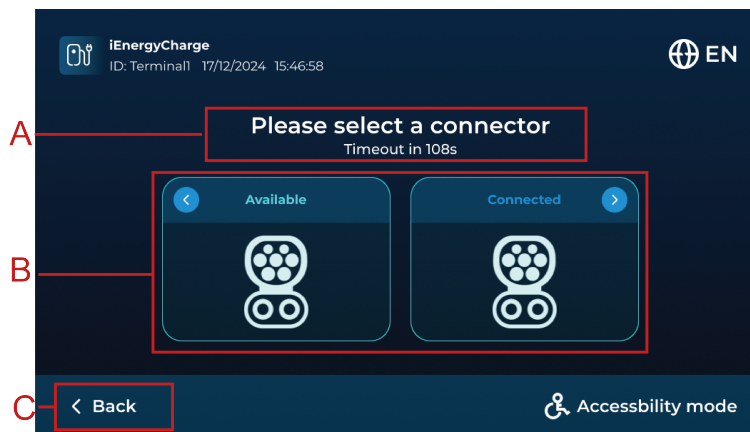

No.	Description
A	Indicate that a charging connector should be selected before the countdown ends. If the timer runs out, the system will cancel the charging process and return to the Authentication Method Selection Page.
B	Display the charging connector ID and its status. The connector status can be one of the following: <ul style="list-style-type: none"> Available: The connector is currently available, not connected to any EV.

No.	Description
<ul style="list-style-type: none"> • Connected: The connector is available and has been connected to an EV. • Occupied: The connector is now occupied. In this case, the current charging power and the time spent in charging will be shown on the screen. • Unavailable: The connector is currently not available. 	
C	Cancel Selection: Return to the Authentication Method Selection Page.

Select a connector that is “Available” before the countdown ends, and the screen will display the plug-in prompt.



If only one connector is available and the other is either occupied or unavailable, the system will assign the available connector to you and display the plug-in prompt.

7.1.3 Plug Connector for Charging

NOTICE

- Plug or unplug the charging connector neatly at one go. Do not shake it.
- Do not bend or squeeze the charging connector, which may result in mechanical damage.
- Do not pull out the charging connector in the middle of a charging process.

After selecting the connector, the screen will display the plug-in prompt.

- Tapping **Cancel** will exit the plug-in process and return to the Connector Selection Page.

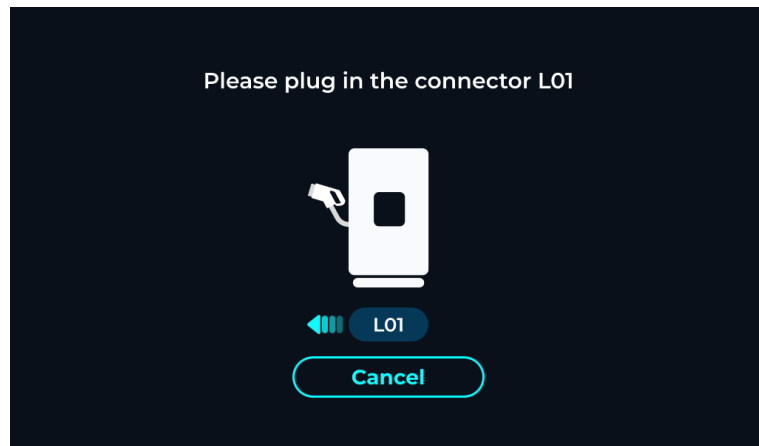

- If the connector is correctly plugged into the charging port of the EV, the Charging Preparation Page will appear. Tapping **Cancel** will abort the charging process.

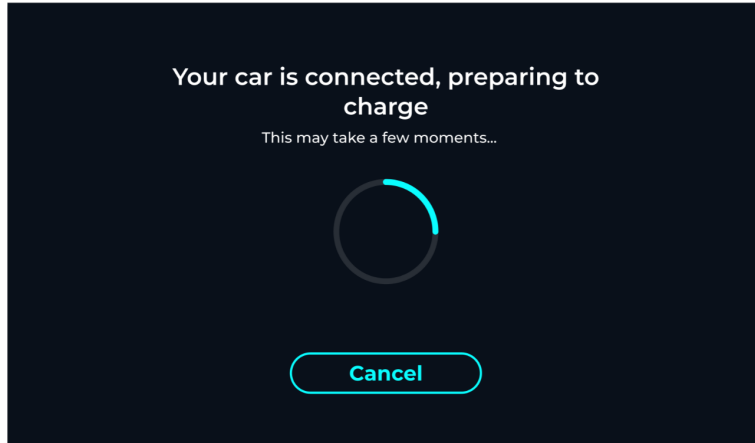

If the connector is plugged in but the process takes too long and times out, the screen will return to the Connector Selection Page with a timeout message. Unplug the connector, reselect one, and plug it in again to restart the process.

7.1.4 View Charging Information

Once the charging preparation is complete, the EV starts charging, and the screen displays the charging details, as shown below:

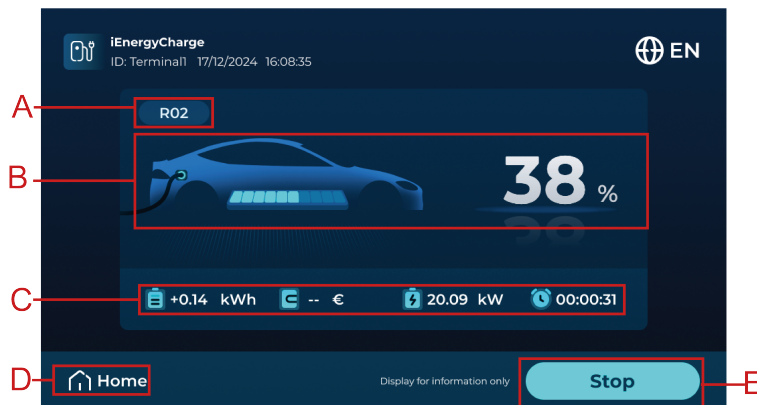

No.	Description
A	Charging connector ID.
B	Progress of charging (%).
C	Charging details, including the charging power (kW), charging cost, power delivered (kWh), and time spent in charging (HH:MM:SS).
D	Home button. Tap this button to go to the home page without stopping the charging process.

No.	Description
E	Stop button. Tap this button, confirm your action by swiping a card, and go to the interface for ending the charging process.

7.1.5 Stop Charging

Once the EV is fully charged, the system will automatically stop charging. To stop charging manually, tap **Stop** on the Charging Details Page. See [7.1.4 View Charging Information](#). After charging is complete, the screen will prompt you to return the charging connector and display details of the charging session, including the charging power (kW), charging cost, power delivered (kWh), and time spent in charging.

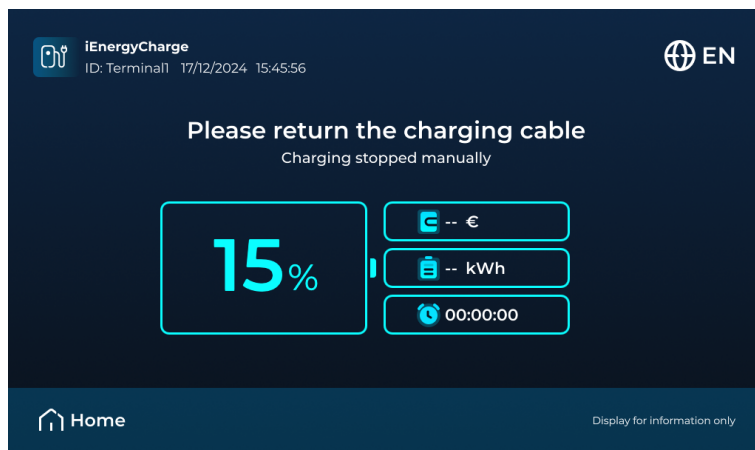

7.2 Other Functions

7.2.1 Dual Charging

Dual Charging Setup

The product supports dual charging, allowing two charging connectors to operate simultaneously. When both connectors are available, after initiating charging with one connector, return to the Authentication Method Selection Page by tapping **Home** on the Charging Details Page. The other connector can then be set up for charging following the same steps. For further details, refer to [7.1 Charging Procedure](#).

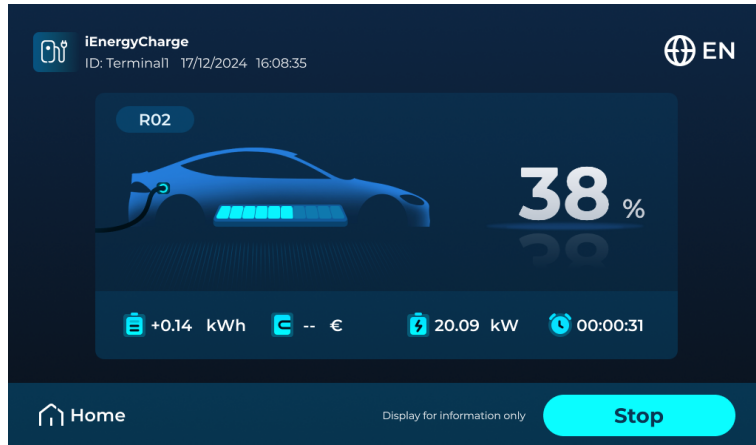

Switching Between Charging Details

After charging has started with both connectors, you can switch between their charging details from either connector's Charging Details Page. Tap **Home** to access the Connector Selection Page, then tap the other connector to view its details.

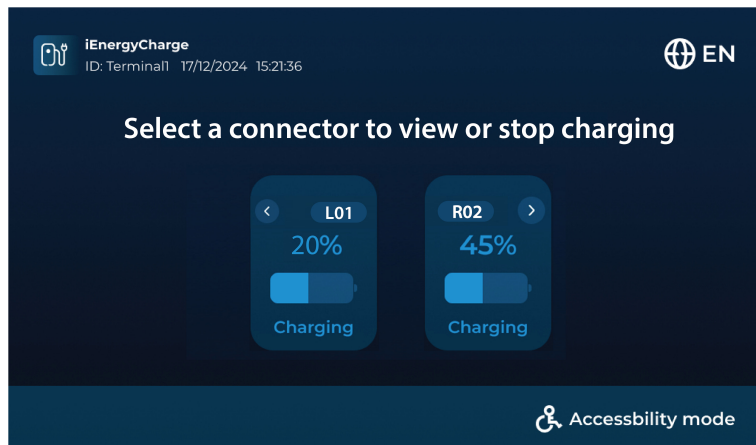

If using credit card or RFID card, tap the card at the designated spot to view the charging details of the corresponding connector.

7.2.2 Change System Language

The system supports languages including English, Dutch, German, French, Spanish, Norwegian, and Italian, with English as the default system language.

Step 1 Tap the icon  in the top-right corner of the screen to enter the Language Selection Page.

- In the default interface, the Language Selection Page appears as follows:

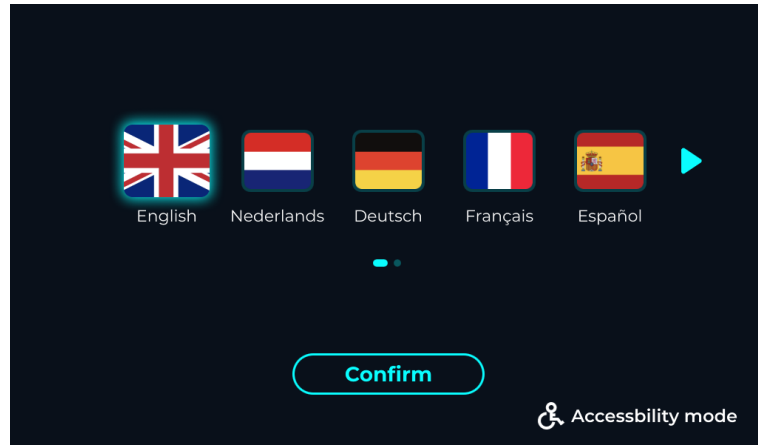

- In Accessibility mode, the Language Selection Page appears as follows. Tap **Exit** to exit Accessibility Mode and return to the default interface.

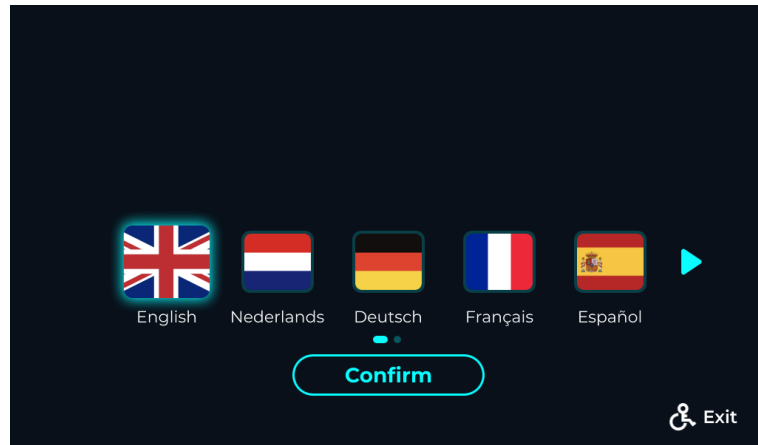

Step 2 Swipe left or right to select the desired language and tap **Confirm** to complete the language switch.

--End

7.2.3 Emergency Stop

In case of an emergency or device malfunction during charging, follow these steps to stop the charging process immediately:

- Step 1** Press the red emergency stop button on the right side of the device. The screen will display a message indicating that the system is in emergency stop mode, and charging will cease. After that return the connector.

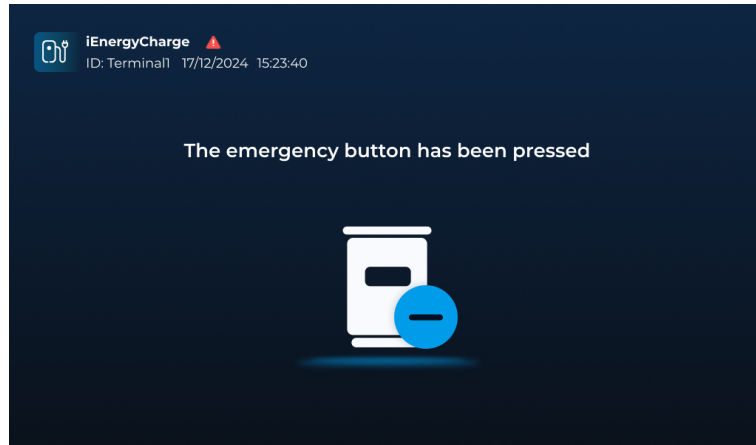

Step 2 Once the emergency or issue is resolved, reset the emergency stop button by rotating it. The product will resume normal operation, and the screen will show the Authentication Method Selection Page.

--End

7.2.4 Device Fault Diagnosis

When a fault occurs, the device will be unable to perform charging operations.

Step 1 The system will detect the fault, display the Error Page, and navigate to the Error List Page.

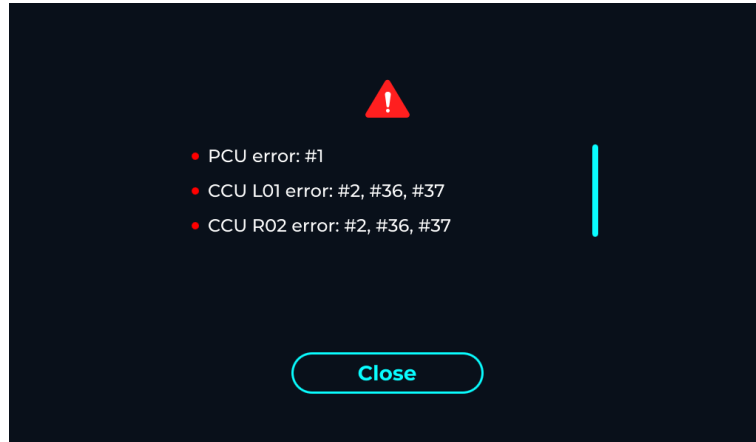

Step 2 Tap **Close** to return to the Error Page. To revisit the Error List Page, tap the icon  in the top-left corner.

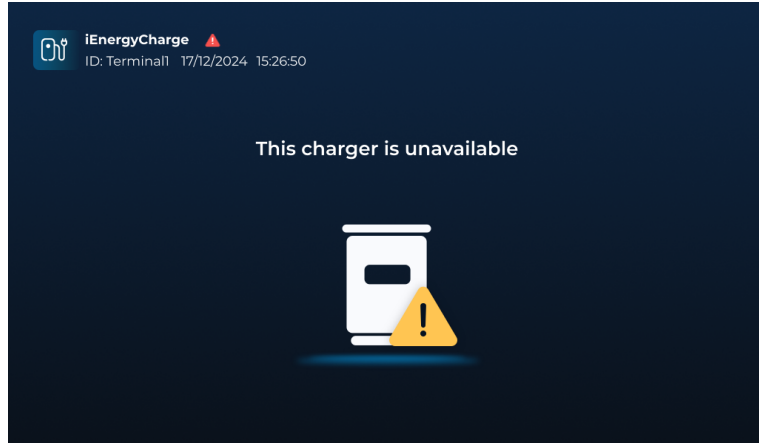

--End

7.2.5 Network Connection Diagnosis

OCPP defines the protocol standard for network interconnection between the device and the charging management platform. The device accesses to OCPP via network connection. In case of a network error, the device cannot access to OCPP.

Network error may arise no matter which state the device is in. A network error icon will show on the screen in case of anything abnormal with the network, and disappears after the network has restored to normal status. The abnormal status includes:

- Network connection is normal, but the device cannot access to OCPP.

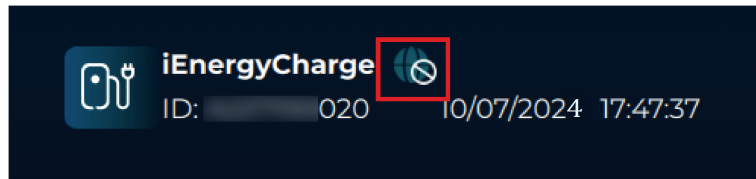

- No network connection, and the device cannot access to OCPP.

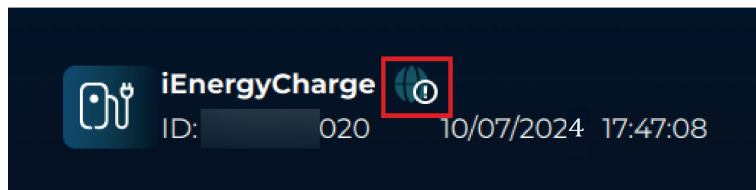

8 iEnergyCharge App

iEnergyCharge App is a tool that allows users to operate and manage their EV chargers. Users can complete account settings and charger configuration, manage charge cards, operate the charger, and reach customer service on the App.



- iEnergyCharge needed for commissioning only if the charger is used standalone, otherwise need to use iSolarCloud.
- Depending on the version of iEnergyCharge you are using, the user interface might be slightly different.

8.1 Install iEnergyCharge App

Requirements

- Mobile OS: Android 6.0 or later, iOS 11.0 or later;
- The phone can connect to WLAN or 2G/3G/4G/5G network;
- The phone has sufficient storage space to install the App;
- The phone has sufficient battery power.

Steps

Step 1 Search for **iEnergyCharge** in Google Play Store or App Store (iOS), or scan the QR code below with a mobile phone, and download the App following the onscreen instructions.



iEnergyCharge

Step 2 Tap the downloaded installation package and follow the onscreen instructions to complete the installation.

--End

8.2 Create an Account

Two types of account are available, Owner and Retailer/Installer.



- **Retailer/Installer:** Users who provides services for owners. Installer users can use the iEnergyCharge App for guided commissioning and site setup, global monitoring of the operation of charging pools and equipment, and can perform operational and maintenance repairs via the App when equipment fails. Retailer/Installer accounts do not support starting or stopping charging.
- **Owner:** Users who will own or already own charging pools. Owner users can use the iEnergyCharge App for charging, card management, and configuring chargers.
- After logging into the App, the content displayed varies depending on the user role and device type.

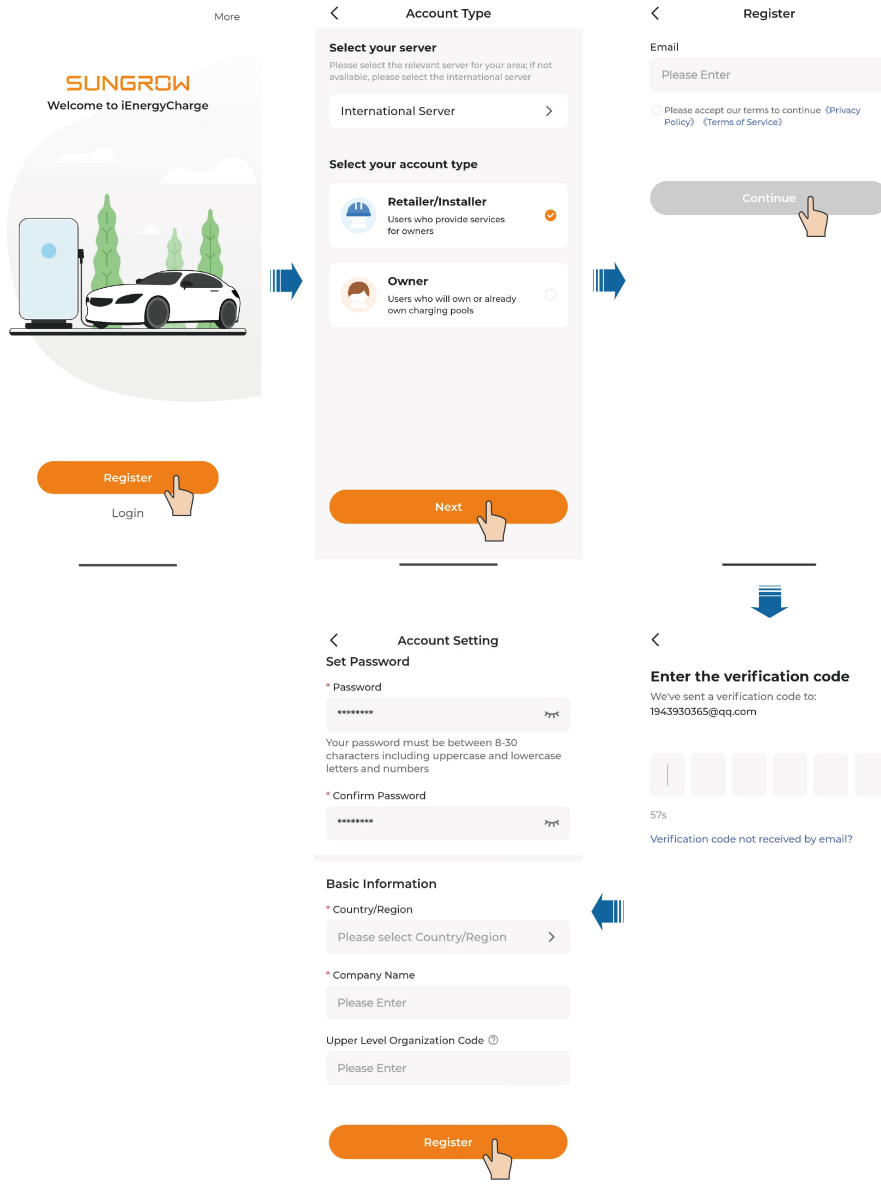

Step 1 Tap **Register**.

Step 2 Select a **Server**, then choose to create an **Retailer/Installer** or **Owner** account.

Step 3 Enter an email address, agree to the privacy policy and terms of service, and tap **Continue**.

Step 4 Enter the verification code you have received through email. If you do not receive a code by e-mail, please check your spam folder or ask customer service or the installer for the e-mail address that can be added to the safe senders.

- Users in mainland China may choose **Chinese Server**. Users in Europe may choose **European Server** and those in Australia may choose **Australian Server**. Users in other countries/regions may choose **International Server**.
- You can reach your upper-level retailer/installer for the "Code of Upper Level Installer/Retailer". Entering this code indicates that your organization is subordinate to an upper-level retailer/installer. If there is no upper-level retailer/installer organization, it is not necessary to fill in.

Step 5 Enter a password, which should be 8–32 characters long and contain uppercase letters, lowercase letters, and numbers. Then, select the country/region, and tap **Register**. An account is now created.

--End

8.3 Log in to an Account

Requirements

- You have installed the iEnergyCharge App;
- You have created an iEnergyCharge account, or obtained an account and password from the retailer/installer or SUNGROW.

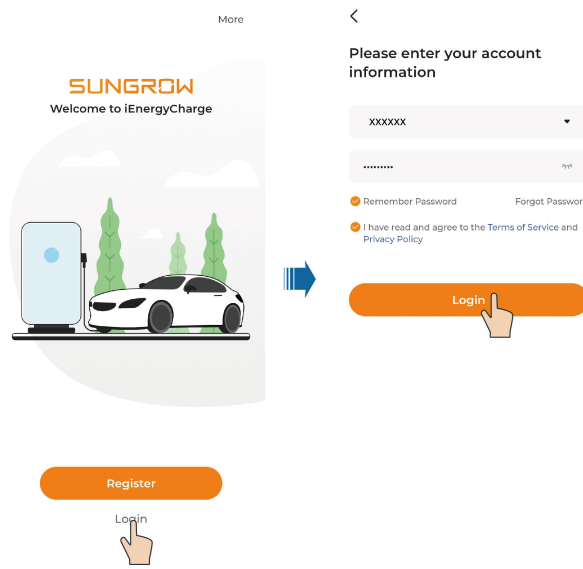

Step 1 Open the iEnergyCharge App, and tap **Login**.

Step 2 Enter your account name and password on the login screen, and tap **Login**. You will then go to the **Home** screen of the App.

--End

8.4 Device Operation and Maintenance

For more detailed information regarding the use of iEnergyCharge App, see [iEnergyCharge User Manual](#). You can also open the App and choose **Account > Support > User Manual** to view the manual.

Alternatively, you can scan the QR code below to view the manual.



9 Maintenance

9.1 Inspection Instructions

It is suggested to perform regular inspections on the device, so as to extend its service life. The inspection interval should be determined with on-site conditions taken into consideration. In case the device works in extreme weather conditions, be sure to shorten the inspection interval and increase inspection frequency.

- Before inspection, power off the device. For details, see [9.2 Power off the Charger](#).
- In case of a fault with the device, contact your local service provider or manufacturer immediately. Do not open the device without permission.
- If some devices need to be replaced during the inspection, please contact SUNGROW.
- Losses caused by failing to perform inspections in compliance with the instructions specified in this manual will not be covered by the warranty.
- Do not perform inspections on the device on rainy, humid, or windy days. SUNGROW shall not be held liable for any possible outcome resulted from inspections in such weather conditions.
- To reduce the risk of electric shocks, do not perform inspections that are not specified in this manual. If needed, please contact SUNGROW for inspection and repair services. Otherwise, damages caused therefrom will not be covered by the warranty.

9.2 Power off the Charger

Power off the charger first before performing maintenance.

CAUTION

Even if the charger has stopped running, it may still be hot and cause burns. Work on it wearing safety gloves after it cools down.

Following the instructions below to power off the charger. Otherwise, it may lead to device damage or personal injuries.

- Step 1** Ensure the charging connector is detached from the EV.
- Step 2** Switch off the AC circuit breaker in the upstream power distribution box.
- Step 3** Open the front door of the charger. Then switch off the MCCB, SPD circuit breaker, charger internal power supply MCB, and fan power supply MCB in sequence.
- Step 4** (Optional) When a dispenser is connected, switch off the dispenser power supply MCB inside the charger. Then, follow the dispenser manual's power-off steps to de-energize its internal MCBs.

Step 5 Wait for 10 minutes before proceeding with voltage test.

- a. Ensure that the indicator lights and the screen are both off.
- b. Measure the voltage at the two AC output copper bars in the charger using a multimeter set to the AC mode to confirm that the input voltage is 0.

Table 9-1 AC Input Voltage of the Charger

Test point 1	Test point 2	Voltage
L1	L2	0V
L1	L3	0V
L2	L3	0V
L1		0V
L2	N	0V
L3		0V
L1		0V
L2	PE	0V
L3		0V

- c. Measure the voltage between L and N, and between L and PE of the dispenser using a multimeter set to AC mode to confirm the voltage is 0.

Table 9-2 Power Supply Voltage of the dispenser

Test point 1	Test point 2	Voltage
L	N	0V
L	PE	0V

- d. Measure the voltage between each DC+ output copper bar and its corresponding DC- output copper bar using a multimeter set to DC mode to confirm the voltage is 0.

Table 9-3 DC Input Voltage of the Charger

Test point 1	Test point 2	Voltage
DC1+	DC1-	0V
DC2+	DC2-	0V

Step 6 Once the voltage test is completed and the results meet the requirements, the charger is powered off.



During operation of the same charging system, maintenance on any dispenser is prohibited if the charger or connected dispenser is active. For maintenance, follow the steps above to shut down the device.

--End

9.3 Routine Inspection

It is recommended to perform routine inspections on the device once every 6 months. However, the actual inspection interval is subject to the operating environment.

Inspection Item	Inspection Method	Recommended Inspection Interval
Device exterior	<ul style="list-style-type: none"> • Check if there is any deformation with the enclosure of the device. • Check if there is paint peeling on the exterior of the device. • Check if the nameplate and marks on the device are all legible. • Check if there is anything abnormal with the exterior of peripheral components such as the charging connector holder and antenna. 	Once every 6 months
Device structure	<ul style="list-style-type: none"> • Check if the parts and components of the device are secure and reliable. • Check if there is any damage to the internal power units, main control board, auxiliary low-voltage power supply, charging interface, and power supply interface. • Clean the dust-proof fabric and dirt and dust inside the device, and check if there is any wet spot. 	Once every 6 months
Charging connector and charging cable	<ul style="list-style-type: none"> • Check the charging connector for any foreign matters. Ensure the pins inside the connector are clean without dirt. Clean off the foreign matters, if any, in time. • Check the charging connector and charging cable for deficiency, crack, abrasion, damage, wire exposure, etc. • If the charging connector freezes to the dispenser, it is recommended to 	Once every 6 months

Inspection Item	Inspection Method	Recommended Inspection Interval
	<p>carefully remove the ice with a cordless heat gun and a plastic scraper. During the heating process, please ensure that the temperature does not exceed 60°C and continuously move the heat gun back and forth to prevent damage to the charging connector or cable due to overheating.</p>	
Electrical connections	<ul style="list-style-type: none"> • Check if the electrical line is burnt or has aged and if the fixing screws are loose. • Check whether the grounding cable is properly connected to allow for reliable grounding. • Check the cables for deficiency, crack, abrasion, damage, wire exposure, etc. • Other inspection items can be arranged based on the actual situation on the site. 	Once every 6 months
LCD screen	<ul style="list-style-type: none"> • Check the display of the screen for broken or cracks. • Check the brightness of the screen and whether the display definition is normal. • Click the screen to operate and check whether the touch function is normal. • Check the waterproof performance around the screen and the plastic panel. 	Once every 6 months
Fan	<ul style="list-style-type: none"> • Check the fan and the fan opening for any foreign matters, and remove them promptly if found • Check whether the fan is operating normally during runtime. 	Once every 6 months

9.4 Troubleshooting



In case of a fault with the device, please contact your local service provider or manufacturer immediately. Do not open the device without permission.

Table 9-4 Charge-stopped Code

Fault	Text displayed	Fault cause	Solutions
Emergency stop (EV-side)	EV_E_Stop	A change from State C to State B is triggered on the EV side, resulting in an emergency stop of the EV charging process.	Pull out the charging connector and stop the charging process.
Stopped due to error (EV-side)	EV_Reported_Error	An error code has been set in the request message by the EV in a communication message.	Pull out the charging connector and stop the charging process.
SLAC failed	SLAC_Match_Failure	SLAC process handshake failed.	Pull out the charging connector and stop the charging process.
SDP failed	SDP_Handshake_Failure	SDP process handshake failed.	Pull out the charging connector and stop the charging process.
UDP connection failed	UDPv6_Server_Fault	UDP server connection establishment failed.	Pull out the charging connector and stop the charging process.
TCP connection failed	TCPIPv6_Server_Fault	TCP server connection establishment failed.	Pull out the charging connector and stop the charging process.
Protocol handshake failed	Protocol_Handshake_Failure	Communication over handshake protocol between the EV and the device failed due to protocol mismatch.	Pull out the charging connector and stop the charging process.
Service parameter interaction failed	Service_Incompatibility	During ServiceDiscovery/PaymentDetail interaction between the EV and the device, the communication is interrupted, or the	Pull out the charging connector and stop the charging process.

Fault	Text displayed	Fault cause	Solutions
		request does not conform to the protocol.	
Communication parameter interaction failed	Charge_Parameter_Incompatibility	During ChargeParameter message interaction between the EV and the device, the parameters do not match, the communication is interrupted, or the charging process is stopped.	Pull out the charging connector and stop the charging process.
cableCheck fault	Cable_Check_Fault	During CableCheck message interaction between the EV and the device, the parameters do not match, the communication is interrupted, or the charging process is stopped.	Pull out the charging connector and stop the charging process.
preCharge fault	Precharge_Fault	During Precharge message interaction between the EV and the device, the parameters do not match, the communication is interrupted, or the charging process is stopped.	Pull out the charging connector and stop the charging process.
currentDemand fault	Current_Demand_Fault	During CurrentDemand message interaction between the EV and the device, the parameters do not match, the communication is interrupted, or the charging process is stopped.	Pull out the charging connector and stop the charging process.

Fault	Text displayed	Fault cause	Solutions
DC output overvoltage protection	DC_Output_O vervoltage_Pr otection6	The current DC output voltage stays above 1014V for over 1s	Pull out the charging connector and stop the charging process.
DC output undervoltage protection	DC_Output_U ndervoltage_ Protection	The current DC output voltage stays below 185V for over 10s	Pull out the charging connector and stop the charging process.
DC output overcurrent protection	DC_Output_O vercurrent_Pr otection	The current DC output current exceeds 325A	Pull out the charging connector and stop the charging process.
Frame communication timed out	Frame_Comm unication_Tim eout	During communication between the EV and the device, the EV did not initiate a further request, and frame communication timed out.	Pull out the charging connector and stop the charging process.
Communication sequence abnormal	Communication_Sequence_Fault	During communication between the EV and the device, the request message sequence sent by the EV does not conform to the protocol.	Pull out the charging connector and stop the charging process.
PCU module apply failed	Pcu_Modules_Applied_Failed	During the charging process, application for module resource failed.	Pull out the charging connector and stop the charging process.
DC output short-circuit fault	DC_Output_S hort_Circuit_E rror	The dispenser detects a short-circuit in positive/negative output cables when performing short-circuit detection in the CableCheck phase.	Pull out the charging connector and stop the charging process.

10 Appendix

10.1 Technical Data

Table 10-1 Technical Data

Technical parameters	IDC480E-C Charger
Charging connector	
Connector type	CCS2
Number of EV served	Max. 4
Cable type	Air cooling (all in one) Air cooling or liquid cooling (optional dispenser)
Cable Length	≤10 m
Cable management system	Arm CMS
EVSE-vehicle protocol	DIN SPEC 70121 ISO 15118
DC output	
DC output power ⁽¹⁾	240 kW, 320 kW, 360 kW, 400 kW, 480 kW
DC output voltage	150 Vdc - 1000 Vdc
DC output current	2 * 400 A boost 600 A (all in one) 2 * 400 A boost 600 A or 1 * 500 A boost 600 A (optional dispenser)
AC input	
Grid voltage	3 / N / PE, 380 Vac / 400 Vac (±10 %)
Nominal grid frequency	50 Hz / 60 Hz
Earthing system	TN-C / TN-S / TN-C-S / TT
Power factor	≥ 0.99
Total harmonic distortion (THDi)	< 5 % at full output power

Technical parameters	IDC480E-C Charger
Overvoltage category	OVC III, DIN EN 60664-1
Efficiency	
Max. efficiency	96.5 %
Protection	
Integrated AC fault current detection	Yes
Overload protection	Yes
Over/under voltage protection	Yes
Over-current protection	Yes
Short-circuit protection	Yes
Leakage current protection	Yes
Over-temperature protection	Yes
Surge protection	Yes
Emergency stop	Yes
User interface	
Display	10-inch color touch screen
Language	English, Spanish, German, French, Dutch (standard) Other languages available by firmware upgrade
Authentication	RFID-card / Plug & play / Auto-charge (standard) Plug & charge / Debit or credit-card (optional)
Firmware update	OTA (over-the-air) by iEnergyCharge Web interface
RFID system	ISO / IEC 14443 A / B ISO / IEC 15693
Energy metering	MID-certified meter integrated Eichrecht / PTB-certified meter integrated (optional)

Technical parameters	IDC480E-C Charger
Communication interface	WLAN / Ethernet / 4G
Communication protocol (charger-to-CSMS)	OCPP 1.6J Ready for OCPP 2.0.1
Mechanical data	
Dimensions (W*H*D)	850 mm * 2300 mm * 950 mm
Weight	≤ 950 kg
Installation method	Floor mounted
Environmental data	
Enclosure rating	IP65
Anti-corrosion degree	C5
Mechanical impact protection	IK10 (enclosure) / IK8 (screen)
Operating ambient temperature range	-35 °C-55 °C
Allowable relative humidity range	5 % - 95 % (non-condensing)
Max. operating altitude	≤2000 m
Cooling method	Smart forced air cooling
Certification and standards	
Compliance	ETSI / EN 300 328, EN 300 330, EN 301 489-1 / 3 / 17 / 52, ETSI / EN 301 908-1 / 13, EN 50665, BS/ EN IEC 61851-1, BS / EN IEC 61851-21-2, BS / IEC EN 61851-23 / 24, EN IEC 62311
Warranty	3 years (standard)

note(1): The output power of IDC480E-C is configurable at power modules level.

10.2 Quality Assurance

When product faults occur during the warranty period, SUNGROW will provide free service or replace the product with a new one.

Evidence

During the warranty period, the customer shall provide the product purchase invoice and date. In addition, the trademark on the product shall be undamaged and legible. Otherwise, SUNGROW has the right to refuse to honor the quality guarantee.

Conditions

- After replacement, unqualified products shall be processed by SUNGROW.
- The customer shall give SUNGROW a reasonable period to repair the faulty device.

Exclusion of Liability

In the following circumstances, SUNGROW has the right to refuse to honor the quality guarantee:

- The free warranty period for the whole machine/components has expired.
- The device is damaged during transport.
- The device is incorrectly installed, refitted, or used.
- The device operates in harsh conditions beyond those described in this manual.
- The fault or damage is caused by installation, repairs, modification, or disassembly performed by a service provider or personnel not from SUNGROW.
- The fault or damage is caused by the use of non-standard or non-SUNGROW components or software.
- The installation and use range are beyond stipulations of relevant international standards.
- The damage is caused by unexpected natural factors.

For faulty products in any of above cases, if the customer requests maintenance, paid maintenance service may be provided based on the judgment of SUNGROW.



Product data such as product dimensions are subject to change without prior notice. The latest documentation from SUNGROW should take precedence in case of any deviation.

10.3 Contact Information

In case of questions about this product, please contact us. We need the following information to provide you the best assistance:

- Model of the device
- Serial number of the device
- Fault code/name
- Brief description of the problem

For detailed contact information, please visit: <https://en.SUNGROWpower.com/contactUS>

SUNGROW

Sungrow Power Supply Co., Ltd.

www.sungrowpower.com