



Liquid Cooling Energy Storage System

TRENE-P500B1044L-2H/TRENE-P499B1044L-2H
TRENE-P400B1044L-2.5H/TRENE-P399B1044L-2.5H
TRENE-P319B1044L-3H/TRENE-P260B1044L-4H

Installation Manual

Version 0.0

www.solaxpower.com

Table of Contents

Safety.....	1
Preparation before Installation	9
Mechanical Installation.....	12
Electrical Connection.....	15
Check before Power-on.....	20
System Power-on and Power-off	20
LED Indicators	21
Technical Data.....	22

Safety















General Notice

1. Contents may be periodically updated or revised. SolaX reserves the right to make improvements or changes in the product(s) and the program(s) described in this manual without the prior notice.
2. The installation, maintenance and grid-related setting can only be performed by qualified personnel who:
 - Are licensed and/or satisfy state and local jurisdiction regulations;
 - Have good knowledge of this manual and other related documents.
3. Before installing the device, carefully read, fully understand and strictly follow the detailed instruction of the user manual and other related regulations. SolaX shall not be liable for any consequences caused by the violation of the storage, transportation, installation, and operation regulations specified in this document and the user manual.
4. Use insulated tools when installing the device. Individual protective tools must be worn during installation, electrical connection and maintenance.
5. Please visit the website www.solaxpower.com of SolaX for more information.

Safety Instruction

For safety reasons, installers are responsible for familiarizing themselves with the contents of the Manual and all warnings before performing installation.

Descriptions of Labels

	CE mark of conformity		TUV certification
	Additional grounding point		Grounding point
	The battery module may explode.		Caution, risk of danger
	Caution, hot surface		Caution, risk of electric shock
	Read the enclosed documentations.		Do not operate this system until it is isolated from mains.
	Keep the system away from open flames or ignition systems.		Keep the system away from children.
	Danger of high voltage. Do not touch live parts for 15 minutes after disconnection from the power sources.		Do not dispose of the device module together with household waste.
	The system must be disposed of at a proper facility for environmentally-safe recycling.		

 **DANGER!**

- According to the local laws and regulations related to high-altitude work, operators must wear PPE, e.g., a helmet, safety belt, or waist harness, when they work at heights, while the other end of the harness must connect to a secure structure to prevent fall incidents.

 **DANGER!**

- Do not connect the positive and negative poles of a battery together. Otherwise, it may be short-circuited. This will result in an excessive flow of current and large quantities of energy for a short time, and then will cause battery leakage, smoke, the emission of flammable gases, thermal runaway, fire, or even an explosion. Therefore, the battery must be powered off before maintenance.
- If a battery is overheated, it will cause leakage, smoke, release of flammable gases, thermal runaway, fire, or even an explosion. Therefore, please ensure that the installation site shall be well ventilated and kept away from high temperatures.
- Do not dismantle, change, shake, drop, crush, impact, cut, penetrate with a sharp object, or any other ways to damage the battery. Otherwise, it may cause leakage, smoke, emission of flammable gases, thermal runaway, fire, or even an explosion.
- Do not mix different types or makes of the battery. Otherwise, it may cause leakage or rupture, resulting in personal injury or property damage.
- The battery electrolyte is toxic and volatile. Never get in contact with the leaked liquids or inhale gases in the case of the battery leakage or odor, and contact professionals immediately. The professional must wear PPE (including but not limited to safety glasses, safety gloves, gas masks, and protective clothing) before powering off the device, and then contact our company at once after removing the damaged battery.
- Normally, the battery will not release any gases. However, in the following situations: burnt, needle-pricked, squeezed, struck by lightning, overcharged, or subject to other adverse conditions that may cause battery thermal runaway, the battery may be damaged or an abnormal chemical reaction may occur inside the battery, resulting in electrolyte leakage or production of gases. If the battery needs to exhaust flammable gas, safe emission measures must be taken to prevent fire and device corrosion.
- Do not use damaged batteries, and ensure that the installation site must be well ventilated.

 **DANGER!**

- Only operate the PCS if it is in a technically faultless condition. Operating a faulty PCS may lead to electric shock or fire.
- Do not attempt to open the enclosure without authorization from SolaX. Unauthorized opening of the enclosure will void the warranty and can result in lethal danger or serious injury due to electric shock.
- Make sure that the PCS is reliably grounded before any operation to prevent the risk of electric shock causing lethal danger or serious injury.
- Only qualified personnel can perform the installation, wiring, maintenance of the PCS by following this document and the related regulations.

 **DANGER!**

- Please make sure that the unit is free from any damage before the electrical connection.
- Do not modify, change, or dismantle the device, do not change the power-on and power-off sequences and the installation procedure written in the document, and please properly and correctly operate it.
- Do not power on the device during installation. Otherwise, it may cause a fire, personal injury, or device damage.
- Must remove earrings, rings, bracelets, watches, and any other metal jewelry before operation, to avoid electrical shock, burns, or even death.
- During operation, special insulated tools must be used to avoid electric shock or short circuit failure. The insulated tools' voltage ratings must exceed the system voltage ratings. Please refer to "Technical Data" for system information.

 **WARNING!**

- Please prepare tools that meet the requirements before installation, and check the number of tools after installation, to avoid leaving them inside the equipment.
- Please ensure that the cabinet has been thoroughly secured before operating it. Otherwise, it may cause personal injury or equipment damage due to tilting or collapsing the cabinet.
- Please ensure that the cabinet's vents and cooling system are working properly when it is running. If the vents are blocked, it will lead to overheating, and even equipment damage or fire hazard.
- Please ensure that the cabinet's vents and cooling system are kept away from heat sources.
- Do not drill holes in the device to avoid equipment failure.
- If the circumstances that may cause personal injury or equipment failure occur, such as, fluid flowing into the equipment, stop operation and power off immediately. Otherwise, it may cause a short circuit or damage.
- Do not open the cabinet doors on a rainy or high humid day ($\geq 80\%$ humidity). If the doors have to be opened on such days, please take proper protective measures.

 **WARNING!**

- Please read the document carefully before installation, operation and maintenance.
- Must arrange fire-fighting equipment in advance according to the local laws, regulations, and standards while installing and commissioning the device.
- Please check that there is no damage to the outer packaging before and after unpacking, and in the process of storage and transportation. The battery shall be correctly placed or stacked in accordance with the requirements stipulated on the labels to prevent damaging or scrapping the battery resulting from crushing or falling.
- Must tighten screws securing cables and on the copper bars according to the torque information specified in the document, and check whether they are tightened periodically. For instance, whether there is any rust, corrosion, or any other foreign object on it, and then clean it up if any. Because the loose screw connections may result in excessive voltage drops and large currents, leading to generating a lot of heat and burning the battery.

 **WARNING!**

- The battery should be charged in time after discharge, to prevent battery damage due to overdischarge. If a battery pack is stored for a long time, please periodically recharge it to protect it from damage according to the storage requirements specified in the document.
- Please charge the battery within the specific temperature range because the low temperature may result in a short circuit. Hence, do not charge it when the temperature is below the low limit of the operating temperature.
- Do not use the battery when you find a bulge, or dents on the battery housing, and contact the installer or professional maintenance personnel to dismantle and replace it. The damaged battery must be kept away from other devices and flammable and explosive articles, and do not contact it except for professionals.
- Before operation, ensure that there are no irritating or burning smells around the battery.
- Do not weld or grind near a battery. Because electric sparks or arcs may cause fires.
- Do not step, lead, stand, or set on the battery.

 **WARNING!**

- Operators must wear PPE while installation and maintenance of the device.
- During operation, avoid touching any part of the PCS.
- Never connect or disconnect the AC and DC connector while the PCS is running.
- Prior to conducting any maintenance, turn off the AC and DC power and disconnect them from the PCS. Wait for 15 minutes to fully discharge the energy.
- Avoid touching the PCS while it is running, as it becomes hot during operation and may cause personal injuries.

 **WARNING!**

- Please wear PPE, such as, protective clothing, insulating shoes, goggles, safety helmets, insulating gloves, etc., when conducting electrical wiring.
- Do not touch the power supply equipment directly, or through conductors or damp objects.
- Do not touch the parts of the equipment of which warning signs are attached, to avoid personal injury or device damage.

 **WARNING!**

- When the liquid cooling unit is running, please do not touch the internal components of the unit with your hands at will to avoid electric shock or injury from the fan blades.

 CAUTION!

- Do not use a straight ladder. When electrical work is involved, a wooden ladder or an insulated ladder shall be used.
- The equipment shall not be used to provide a backup power source in the following circumstances:
 - a. Equipment related to life;
 - b. Sensitive precision instruments;
 - c. Home appliances will be faulty in the case of a power failure during operation.
- Do not power on the equipment until it has been installed and confirmed by professionals.
- In the event of a fire, evacuate immediately and call the local fire services.

 CAUTION!

Safety precautions for liquid cooling unit usage:

- The waste is hazardous. Please properly handle it, and avoid contact of the waste with soil or drainage systems.
- Coolant may cause irritation to eyes, skin, and throat. When handling, wear PPE and use only authorized tools.
- Heating the liquid cooling unit in an empty container may cause an explosion.

 CAUTION!

- If severe vibration or abnormal sound occurs during running or debugging of the unit, please stop all operations and immediately cut off the circuit switch for inspection.
- Do not allow liquids such as water to enter the terminal area of the device during installation and maintenance.
- Only when all the circuit switches are turned off and the internal control board no longer flashes the signal light, can you operate the device circuit and electronic devices, and you must wear anti-static gloves.
- The waste is hazardous. Please properly handle it, and avoid contact of the waste with soil or drainage systems.
- Coolant may cause irritation to eyes, skin, and throat. When handling, wear PPE and use only authorized tools.
- Do not heat the liquid cooling unit in an empty container since it may cause an explosion.

NOTICE!

- The signs and messages on the labels and nameplates attached to the device need to be visible and clear.

NOTICE!

Transportation requirements for battery:

- Relevant qualifications for the transport of dangerous goods must be obtained by the forwarding agent engaged in such businesses, and they must strictly abide by the local regulations for the transport of dangerous goods.
- Please check the battery before transportation. If a battery leaks, smells, or is damaged, do refuse to transport it.
- Please handle gently in the process of loading and unloading, transportation, and moving a battery to prevent bumping, and take effective moisture-proof measures to prevent personal injuries and battery damage.
- Unless otherwise specified, do not transport the batteries, which are classified as dangerous goods, together with food, medicine, or other additives on the same means of transport.

If the battery leaks electrolyte or any other chemical materials, the electrolyte leakage can lead to toxic gases. Therefore, do not contact with them at all times. In case of accidentally coming into contact with them, please do as follows:

- In case of inhalation: Leave the contaminated area immediately, and seek medical attention at once;
- In case of contact with eyes: Rinse eyes with running water for at least 15 minutes, and seek medical attention;
- In case of contact with skin: Wash the contact area thoroughly with soap, and seek medical attention;
- In case of ingestion: Induce vomiting, and seek medical attention.

If a fire breaks out where the battery is installed, please do as follows:

- In case a battery is charging when the fire breaks out, provided it is safe to do so, press the emergency stop button and unplug the power cable;
- In case a battery is not on fire yet, use a water-based fire extinguisher or a carbon dioxide extinguisher to extinguish the fire;
- In case a battery catches fire, do not try to put it out, and evacuate immediately;
- A battery may catch fire when it is heated above 150°C/302°F. If the battery catches fire, please evacuate immediately since it will generate noxious and poisonous gases.

Recovery of damaged or wasted battery:

- Dispose of the damaged or wasted batteries according to local laws and regulations instead of placing them in the household trash or curbside recycling bins. Otherwise, it may cause environmental pollution or explosions.
- Ensure that the damaged or wasted batteries are not exposed to the following situations: high temperatures, high humidity, direct sunlight, or corrosive environments.
- Contact a battery recycling company to scrap the battery, which leaks electrolytes, or is damaged or expired.
- Please take protective steps to prevent battery short circuits before moving batteries.
- Please keep away from flammable material storage areas, residential areas, and other population centers when transporting and storing the damaged battery.

NOTICE!

- The PCS has an integrated Residual Current Monitoring Unit (RCMU). If an external Residual Current Device (RCD) is required by local regulations, verify the type of RCD required. It is recommended to use a Type-A RCD with a rating of 300 mA unless a lower value is required by the specific local electric codes. When required by local regulations, the use of an RCD type B is permitted.

NOTICE!

- Only connect the PCS to the grid with the permission of the local utility grid company.

NOTICE!

- Please operate according to the safety code for power station.
- Before installation, it is necessary to set up temporary safety fences or warning lines and hang warning signs in the operation area, to prohibit non-staff from entering here.
- Please make sure that the equipment and its associated switches are off before connecting and disconnecting power cables.
- Please check whether the protective housing and insulating sleeve for an electrical component have been installed correctly after finishing installation, to avoid electric shock.
- Must turn off the output switch of the power supply equipment when maintaining its electrical terminal device and power distribution device.
- If the device is required to be powered off during troubleshooting and diagnosis, please do as the following procedure: power off > electricity testing > connecting grounding cable > hanging warning signs and setting up guardrails.
- Must hang up "Do Not Switch On" warning signs on the relevant switches or circuit breakers before completing maintenance, to prevent power connection. Do not switch on before the fault is solved.
- Do not use water, alcohol, oil, or other solvents when cleaning electrical components inside and outside the device.

NOTICE!

- While injecting the liquid, if the injection process is interrupted manually, restart the process from the beginning when resuming.
- During injection, ensure that the hose in the coolant collection tank is fully submerged and maintains proper coolant flow.
- After completing injection and drainage, thoroughly flush the hoses of the inject machine to remove residual coolant.
- Use a coolant collection tank with a capacity of 20 liters or more, and keep it clean, dry and free from contaminants.

NOTICE!

If the coolant leaks, please avoid contact with it at all times. In case of accidentally coming into contact with it, please do as follows:

- In case of contact with eyes: Rinse eyes with running water for at least 15 minutes, and seek medical attention;
- In case of contact with skin: Wash the contact area thoroughly with soap, and seek medical attention.

NOTICE!

Grounding Requirements:

- The device's grounding impedance shall meet the requirements of local electrical safety standards.
- The equipment shall be permanently connected to a grounding wire within the building's electrical system. Please check whether the device is reliably grounded before operation. The grounding cable should be removed last while dismantling and maintaining the device.
- Do not start the device if it is not fitted with a grounding conductor.
- All acts against the grounding conductor are prohibited.
- If the device is equipped with a three-pronged socket, make sure that the ground prong is reliably grounded.
- For the device that may generate large contact currents, please make sure that the grounding terminal on the housing has been grounded before powering on, to avoid electric shock.

Cable Requirements:

- When deciding the wire diameter, and connecting or wiring cables, follow the local laws, regulations, and codes to ensure safety.
- When external conditions (e.g., placement method, ambient temperature, etc.) change, the cable type must be verified according to IEC-60364-5-52 or local laws, regulations and standards. For instance, whether the cable's current-carrying capacity meets the requirements.
- Before connecting power cables, please make sure that the cable labels are correctly labelled and the cable terminals are well insulated.
- Do not loop and twist cables while conducting electrical wiring. If the length of the power cable is not enough, please replace it instead of joining or welding. Ensure that all the cables of the correct type and size are fully connected and well insulated, and the edges of cable slots and crossing holes are smooth.
- It is recommended to bundle similar cables with cable ties, to ensure that the inside of the device is neat and tidy and to avoid cable jacket damage.
- Please use fireproof mud to seal the threading openings immediately after finishing wiring, to avoid the entry of water vapour or small animals.
- Cables should be kept away from heaters or other heat sources, because a high temperature environment may result in aging and damage to cable insulation.

Preparation before Installation

Packing List

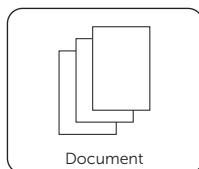
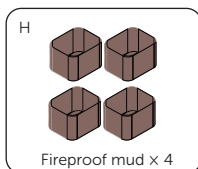
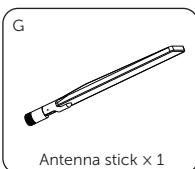
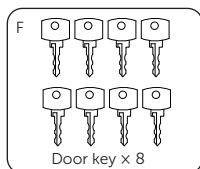
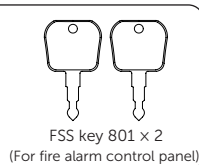
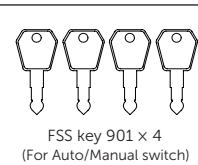
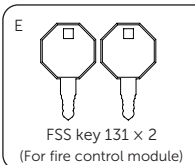
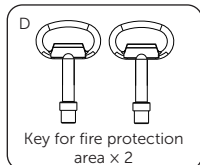
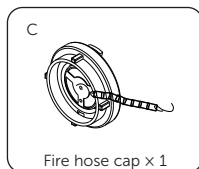
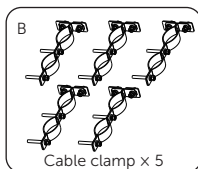
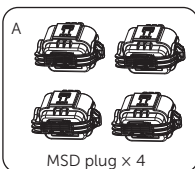
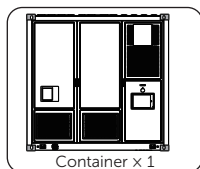

Container Dimensions

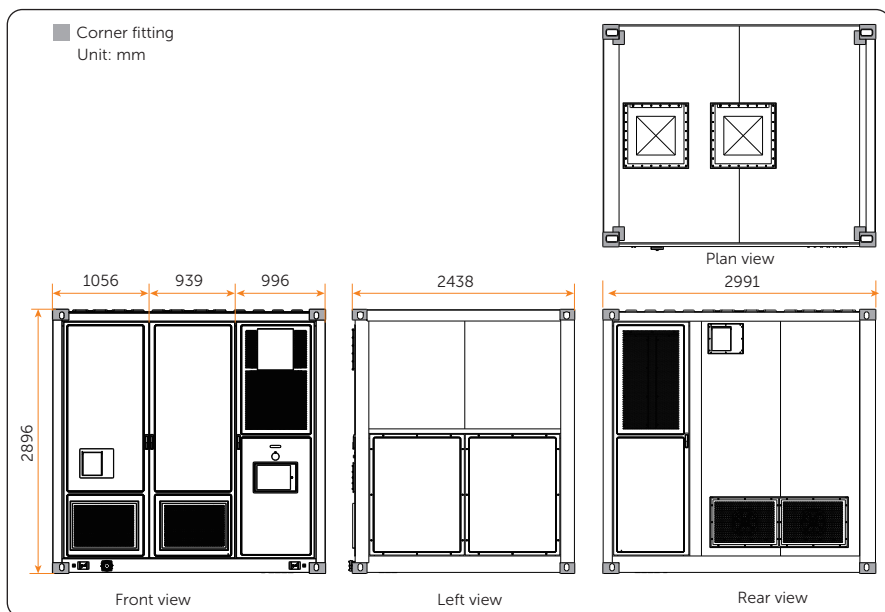

Foundation Requirements

Unit: mm

-  Foundation
-  Steel plate

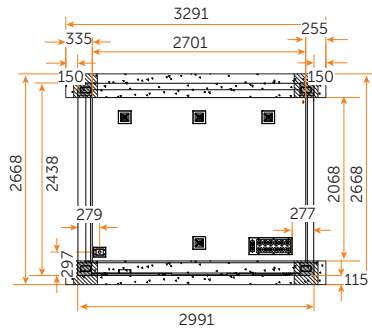
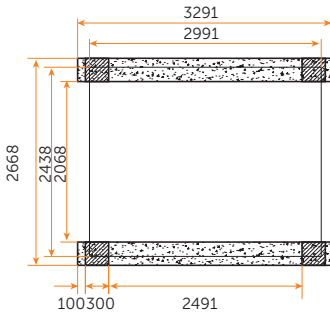
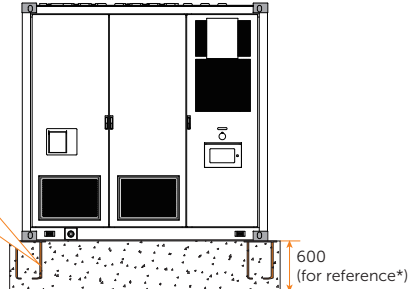
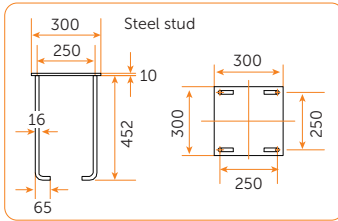

NOTICE!

*: The height of the foundation above the floor is subject to the requirements of local departments and the on-site conditions.

Installation Carrier Requirements

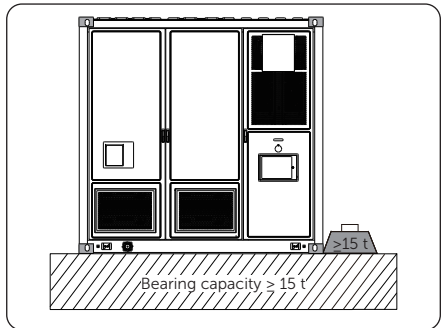
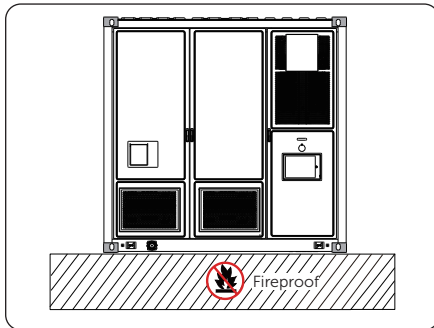

Installation Clearance Requirements

Single Container
Unit: mm

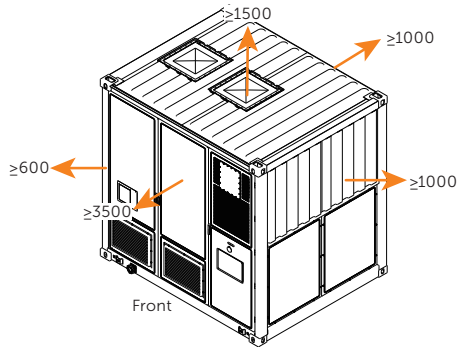

Multiple Containers
Unit: mm

Plan A: In a row, same direction

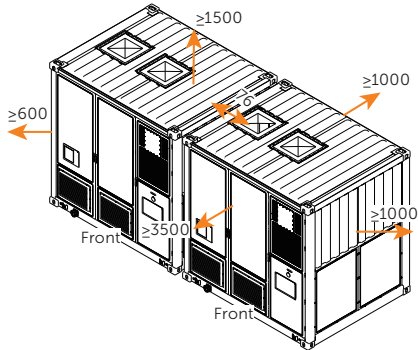

Plan B: In a column, opposite direction

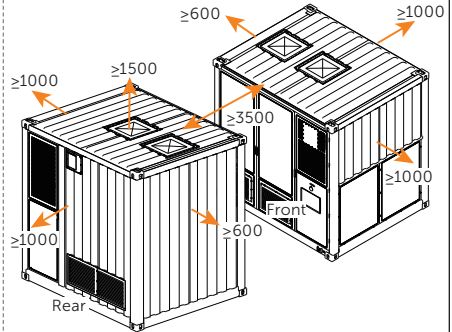

NOTICE!

If multiple containers will be placed side by side, the distance between each two containers must be 76 mm as shown in Plan A. Otherwise, place them in a column as plan B.

Mechanical Installation

Container Hoisting

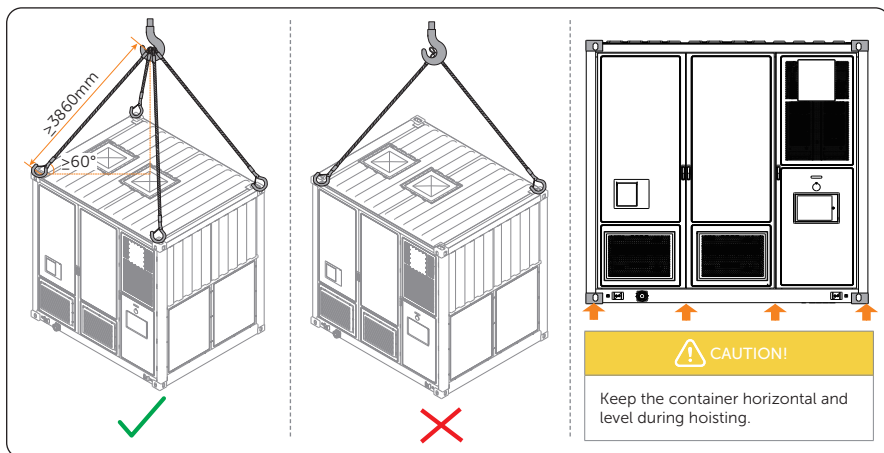

Container Fixing

Weld the embedded steel plates on the foundation to the 4 corner fittings.

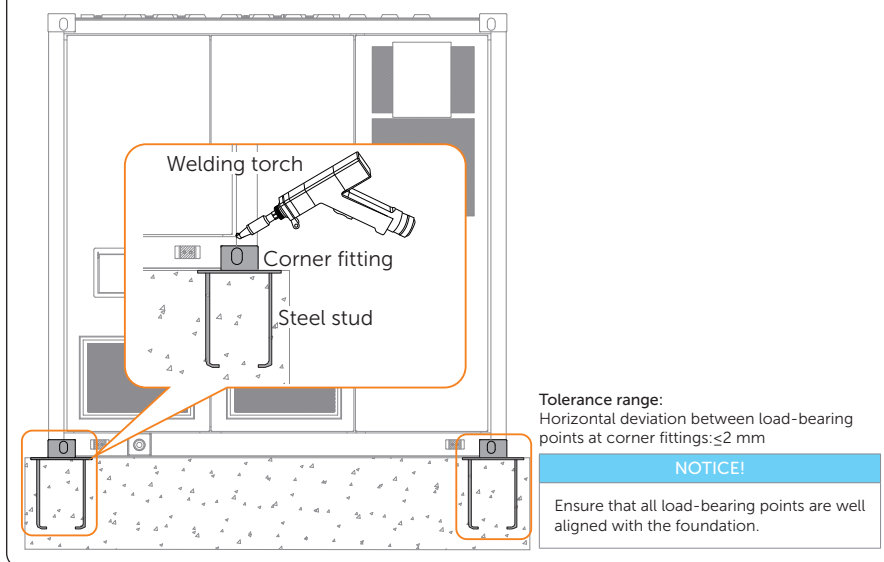

Antenna Installation

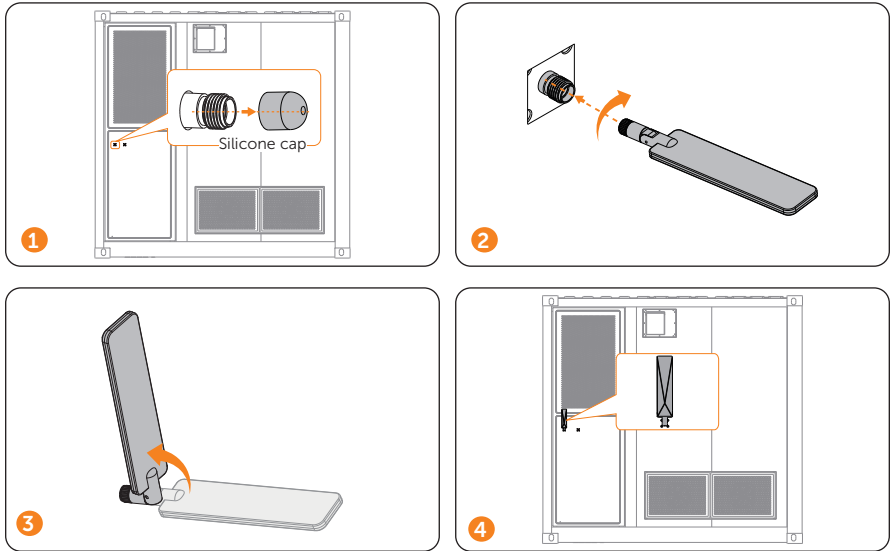

Fire Hose Cap Installation

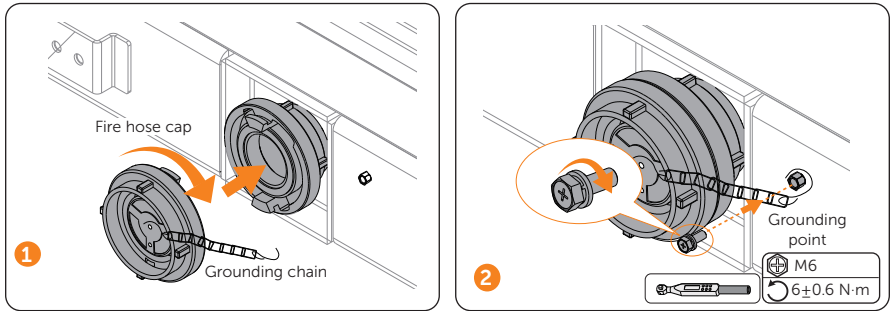

Locking and Unlocking the Container Door

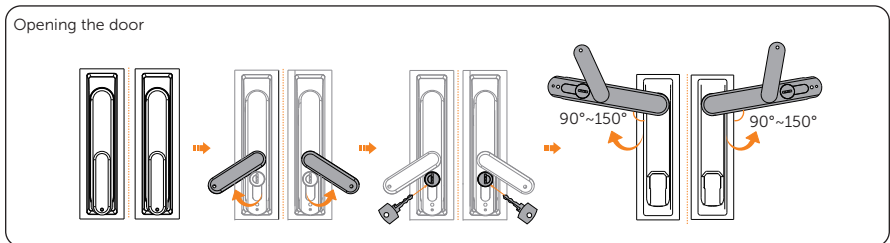

Closing the door

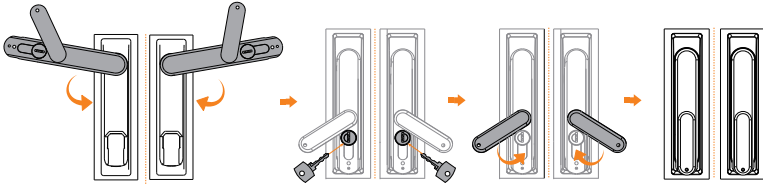

MSD Installation on the Battery Pack

NOTICE!

MSD of the 104S battery pack on the bottom of each battery cluster is unplugged upon delivery to ensure safety.

Follow the steps below to install MSD plug into the MSD socket of the 104S battery pack.

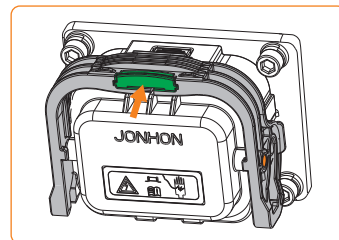
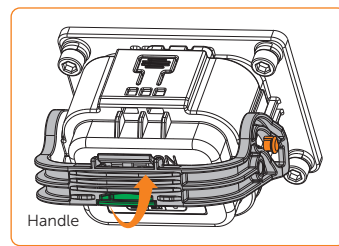
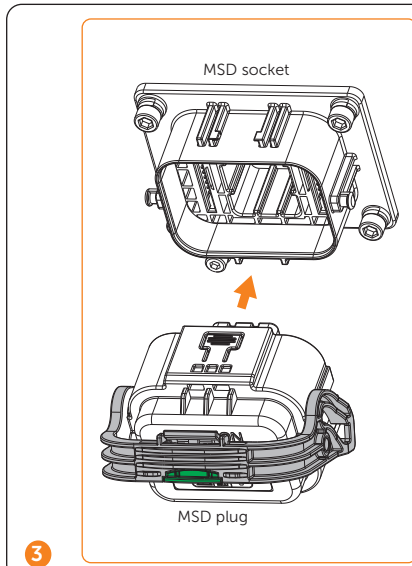
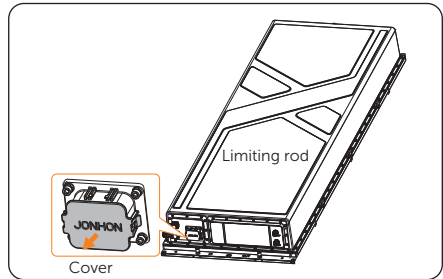
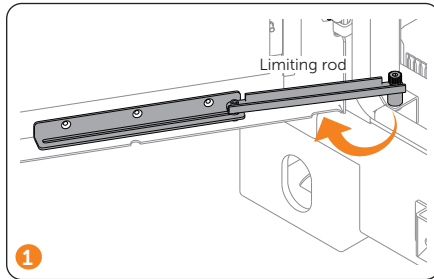

Electrical Connection

Position of the Wired Parts

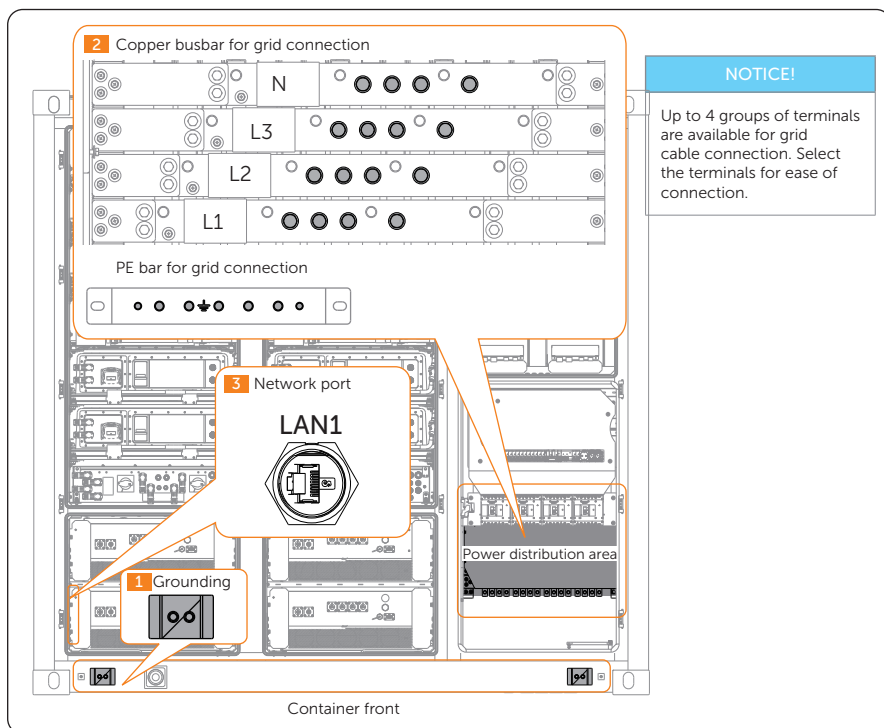

NOTICE!

Up to 4 groups of terminals are available for grid cable connection. Select the terminals for ease of connection.

Container Grounding

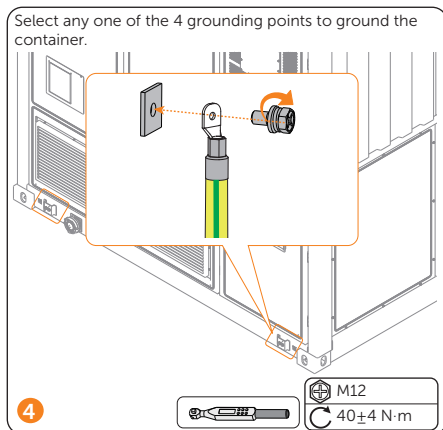
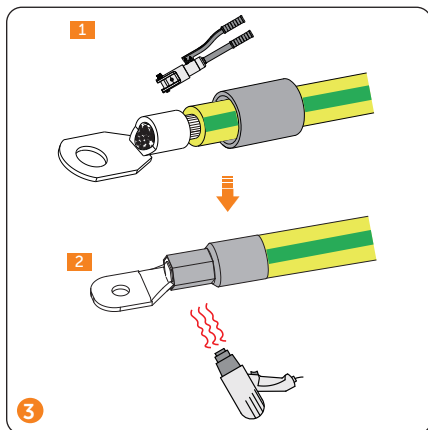
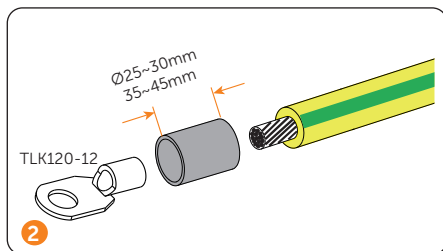
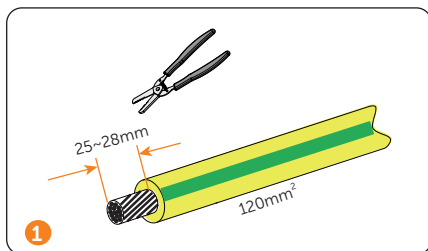

Preparing Grid Cables

Prepare enough grid cables and PE cable of suitable specification for your container model based on the table below.

Table 4-1 Cables and Terminal requirements for multiple container models

Model	Cable Type	Grid Cable (L1, L2, L3 and N)			PE Cable		
		Conductor Cross-section	Quantity	Ring Terminal	Conductor Cross-section	Quantity	Ring Terminal
TRENE-P500B1044L-2H	Single-core copper cable	240mm ²	2 groups	DT240-12	120mm ²	1 pc	TLK120-8
TRENE-P499B1044L-2H							
TRENE-P399B1044L-2.5H		300mm ²	1 group	DT300-12	150mm ²	1 pc	TLK150-8
TRENE-P319B1044L-3H		240mm ²	1 group	DT240-12	120mm ²	1 pc	TLK120-8
TRENE-P260B1044L-4H		185mm ²	1 group	DT185-12	95mm ²	1 pc	TLK95-8

NOTICE!

- The procedure of making grid cables are the same for all container models. This section uses the grid wiring related requirements of TRENE-P500B1044L-2H for example.
- 2 groups of grid cables (L1, L2, L3 and N wire) are required for TRENE-P500B1044L-2H.

Table 4-2 Detailed requirements for making grid cables

Cable Type	Conductor Cross-section	Quantity	Insulation Stripe	Heat Shrink Tubing	Ring Terminal (REC)	Terminal Quantity
Single-core copper cable	L1, L2, L3, N: 240mm ²	2 groups	34~36 mm	Diameter: Ø35~40 mm Length: 70~80 mm	DT240-12	8 pcs
	PE: 120mm ²	1 pc	25~28 mm	Diameter: Ø25~30mm Length: 35~45mm	TLK120-8	1 pc

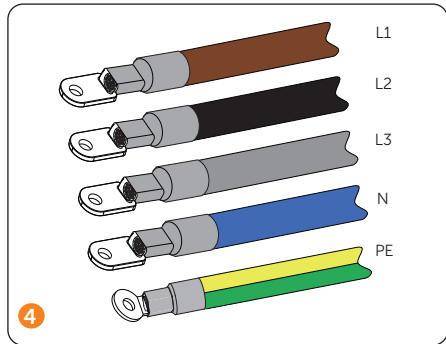
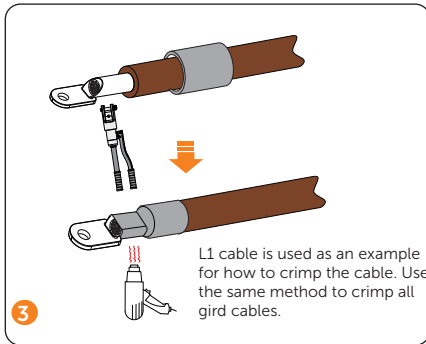
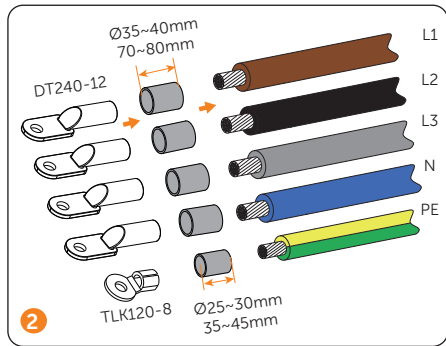
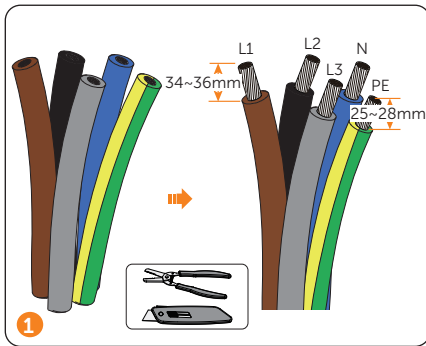

Connecting Grid Cables

Copper busbar

Power distribution area

1

Limiting rod

2

Wire cover

M6
6±0.6 N·m

3

Cable entry plate

M6
6±0.6 N·m

4

5

Note:
Terminal 2 to 6 are commended for connection.

M8
18±1.8 N·m

L1 L2 L3 L4

M12
40±4 N·m

6

M6
6±0.6 N·m

7

Cable clamp

M5

M6

M6/M5
6±0.6/4±0.4 N·m

8

M6/M5
6±0.6/4±0.4 N·m

9

Fireproof mud

10

M6
6±0.6 N·m

Connecting Network Cables

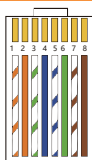

PIN No.	Color	PIN No.	Color
1	Orange-White	5	Blue-White
2	Orange	6	Green
3	Green-White	7	Brown-White
4	Blue	8	Brown

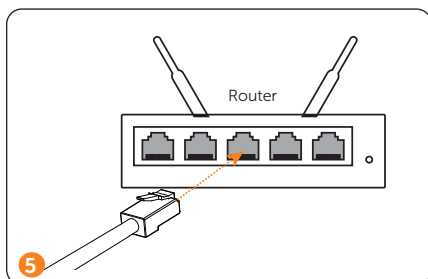
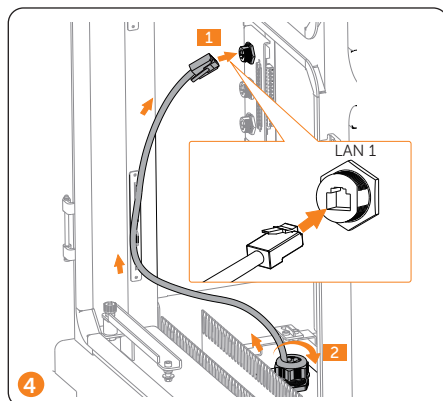
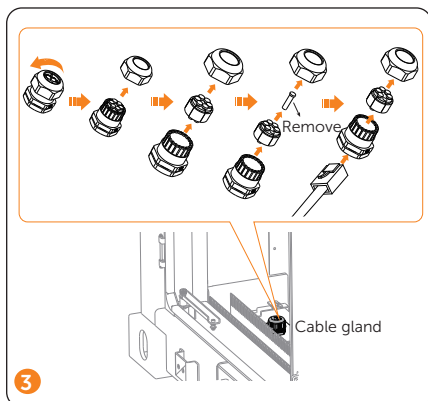
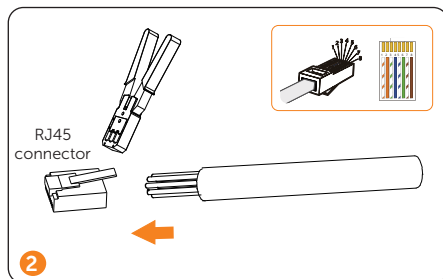
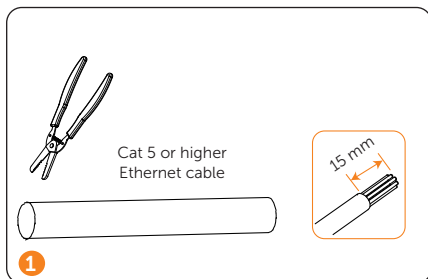

NOTICE!

Keep the sealing plugs on the cable gland for unused terminals.

Check before Power-on

No.	Inspection Item
1	Check if all power cables and communication cables are properly connected.
2	Check if all screws are tightened and meet the torque requirements.
3	Check if the fireproof mud has been properly applied to the cable entries.

System Power-on and Power-off

- Normal Power-on/Normal power-off

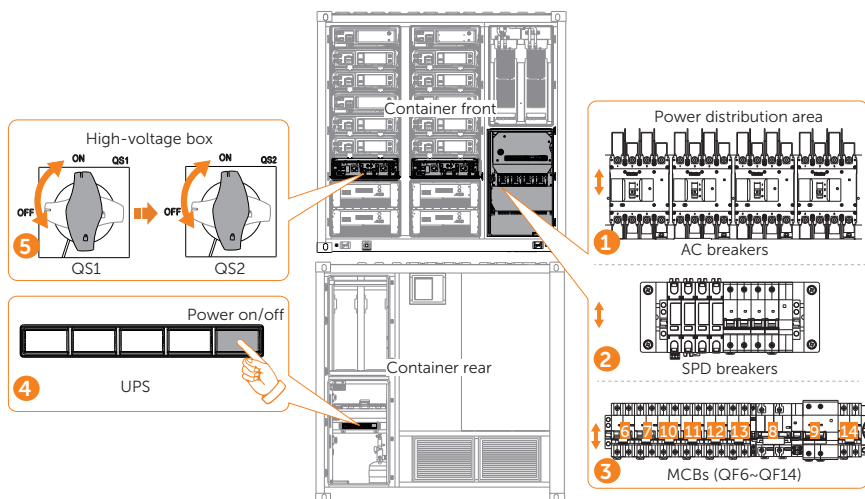

Power on: **1 2 3 4 5**
 (MCB: QF8 > QF9 > QF10 > QF6&QF7 > QF11 > QF12 > QF14 > QF13)

Power off: **3 2 1 5 4**
 (MCB: QF13 > QF14 > QF12 > QF11 > QF6&QF7 > QF10 > QF9 > QF8)

QF	Part in Control	QF	Part in Control
QF6	Liquid cooling unit A	QF11	Dehumidifier
QF7	Liquid cooling unit B	QF12	Thermal fan
QF8	Mains power supply	QF13	Lighting
QF9	Undervoltage protection for main circuit	QF14	Firefighting system and fire fan
QF10	UPS		

- Emergency Power-off

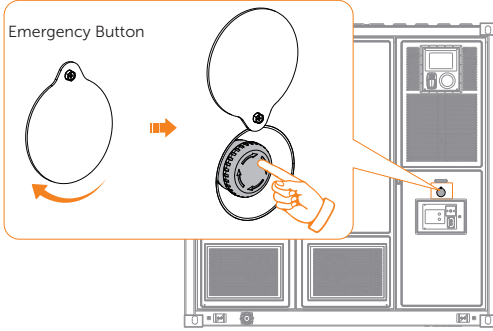

WARNING!

Do not press the emergency stop button unless in an emergency.

Note!

If the emergency stop button has ever been pressed down, please reset it before you power on the system again.

1. Rotate up the cover;
2. Rotate the button according to the arrow direction shown on the button, and then the button will spring back to its original position.

LED Indicators

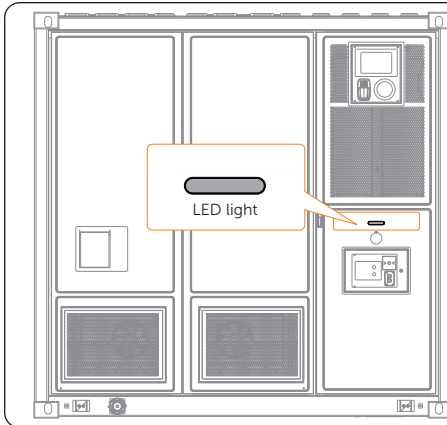

Indicator Light Status	Definition
Solid yellow	Standby
Solid green	Running
Solid red	Fault



Technical Data

Model	TRENE- P500B1044L- 2H	TRENE- P499B1044L- 2H	TRENE- P400B1044L- 2.5H	TRENE- P399B1044L- 2.5H	TRENE- P319B1044L- 3H	TRENE- P260B1044L- 4H
Rated AC Voltage	3 / N / PE, 230 / 400 V 3 / N / PE, 220 / 380 V					
AC voltage range	340 ~ 440 a.c V					
Rated AC Power	500 kW	499.6 kW	400 kW	399.6 kW	319.6 kW	260 kW
Max. Output apparent power	500 kVA	499.6 kVA	440 kVA	399.6 kVA	319.6 kVA	260 kVA
Rated AC current	181.2A*4@230V 189.4A*4@220V	181.1A*4@230V 189.3A*4@220V	145A*4@230V 151.6A*4@220V	144.8A*4@230V 151.4A*4@220V	115.8A*4@230V 121.1A*4@220V	94.3A*4@230V 98.5A*4@220V
Max. output continuous current	181.2A*4@230V 189.4A*4@220V	181.1A*4@230V 189.3A*4@220V	159.5A*4@230V 166.7A*4@220V	144.8A*4@230V 151.4A*4@220V	115.8A*4@230V 121.1A*4@220V	94.3A*4@230V 98.5A*4@220V
Rated AC Frequency	50/60 Hz					
Battery type	LFP / 314 Ah					
Battery capacity	1044 kWh					
Rated battery voltage	832 d.c V					
Battery voltage range	689 ~ 936 d.c V					
Operating Temperature	-30°C to +55°C (>45°C derating)					
Relative Humidity	0 ~ 100% RH					
Protective Class	I					
Altitude	Below 3000 m					
Dimensions (W x H x D)	2991 mm x 2896mm x 2438mm					
Weight	13 t					
Ingress Protection	IP55					

Contact Information





UNITED KINGDOM

 Unit C-D Riversdale House, Riversdale Road, Atherstone, CV9 1FA
 +44 (0) 2476 586 998
 service.uk@solaxpower.com





AUSTRALIA

 21 Nicholas Dr, Dandenong South VIC 3175
 +61 1300 476 529
 service@solaxpower.com.au





TURKEY

 Fevzi Çakmak mah. asım cd. no 88 A Karatay / Konya / Türkiye
 service.tr@solaxpower.com





GERMANY

 Am Tullnaupark 8, 90402 Nürnberg, Germany
 +49 (0) 6142 4091 664
 service.eu@solaxpower.com
 service.dach@solaxpower.com







USA

 +1 (888) 820-9011
 service.us@solaxpower.com





NETHERLANDS

 Twekkeler-Es 15 7547 ST Enschede
 +31 (0) 8527 37932
 service.eu@solaxpower.com
 service.bnl@solaxpower.com





POLAND

 WARSAW AL. JANA P. II 27. POST
 +48 662 430 292
 service.pl@solaxpower.com





SPAIN

 +34 9373 79607
 tecnico@solaxpower.com





ITALY

 +39 011 19800998
 support@solaxpower.it



BRAZIL

 +55 (34) 9667 0319
 info@solaxpower.com



PAKISTAN

 service.pk@solaxpower.com



SOUTH AFRICA

 service.za@solaxpower.com

Warranty Registration

Please visit the website: <https://www.solaxcloud.com/user-center/> to complete the warranty registration. For more detailed warranty terms, please visit SolaX official website: www.solaxpower.com.



SolaX Power Network Technology (Zhejiang) Co., Ltd.

Add.: No. 278, Shizhu Road, Chengnan Sub-district, Tonglu County,
Hangzhou, Zhejiang, China
E-mail: info@solaxpower.com

